

## MicroHAWK V320-F / V330-F / V420-F / V430-F Barcode Reader

### User Manual



**NOTE**

- All rights reserved.
- No part of this publication may be reproduced, stored in a retrieval system, or transmitted, in any form, or by any means, mechanical, electronic, photocopying, recording, or otherwise, without the prior written permission of OMRON.
- No patent liability is assumed with respect to the use of the information contained herein. Moreover, because OMRON is constantly striving to improve its high-quality products, the information contained in this manual is subject to change without notice. Every precaution has been taken in the preparation of this manual. Nevertheless, OMRON assumes no responsibility for errors or omissions.

Neither is any liability assumed for damages resulting from the use of the information contained in this publication.

**Trademarks**

- Sysmac and SYSMAC are trademarks or registered trademarks of OMRON Corporation in Japan and other countries for OMRON factory automation products.
- Microsoft, Windows, Windows Vista, Excel, and Visual Basic are either registered trademarks or trademarks of Microsoft Corporation in the United States and other countries.
- ODVA, CIP, CompoNet, DeviceNet, and EtherNet/IP are trademarks of ODVA.
- QR Code is a registered trademark of DENSO WAVE INCORPORATED.

Other company names and product names in this document are the trademarks or registered trademarks of their respective companies.

**Copyrights**

Microsoft product screen shots reprinted with permission from Microsoft Corporation.



# Terms and Conditions Agreement

---

## Warranty, Limitations of Liability

### Warranties

---

- **Exclusive Warranty**

Omron's exclusive warranty is that the Products will be free from defects in materials and workmanship for a period of twelve months from the date of sale by Omron (or such other period expressed in writing by Omron). Omron disclaims all other warranties, express or implied.

- **Limitations**

OMRON MAKES NO WARRANTY OR REPRESENTATION, EXPRESS OR IMPLIED, ABOUT NON-INFRINGEMENT, MERCHANTABILITY OR FITNESS FOR A PARTICULAR PURPOSE OF THE PRODUCTS. BUYER ACKNOWLEDGES THAT IT ALONE HAS DETERMINED THAT THE PRODUCTS WILL SUITABLY MEET THE REQUIREMENTS OF THEIR INTENDED USE. Omron further disclaims all warranties and responsibility of any type for claims or expenses based on infringement by the Products or otherwise of any intellectual property right.

- **Buyer Remedy**

Omron's sole obligation hereunder shall be, at Omron's election, to (i) replace (in the form originally shipped with Buyer responsible for labor charges for removal or replacement thereof) the non-complying Product, (ii) repair the non-complying Product, or (iii) repay or credit Buyer an amount equal to the purchase price of the non-complying Product; provided that in no event shall Omron be responsible for warranty, repair, indemnity or any other claims or expenses regarding the Products unless Omron's analysis confirms that the Products were properly handled, stored, installed and maintained and not subject to contamination, abuse, misuse or inappropriate modification. Return of any Products by Buyer must be approved in writing by Omron before shipment. Omron Companies shall not be liable for the suitability or unsuitability or the results from the use of Products in combination with any electrical or electronic components, circuits, system assemblies or any other materials or substances or environments. Any advice, recommendations or information given orally or in writing, are not to be construed as an amendment or addition to the above warranty.

See <http://www.omron.com> or contact your Omron representative for further information.

### Limitation on Liability; Etc.

---

OMRON COMPANIES SHALL NOT BE LIABLE FOR SPECIAL, INDIRECT, INCIDENTAL, OR CONSEQUENTIAL DAMAGES, LOSS OF PROFITS OR PRODUCTION OR COMMERCIAL LOSS IN ANY WAY CONNECTED WITH THE PRODUCTS, WHETHER SUCH CLAIM IS BASED IN CONTRACT, WARRANTY, NEGLIGENCE OR STRICT LIABILITY.

Further, in no event shall liability of Omron Companies exceed the individual price of the Product on which liability is asserted.

## Application Considerations

### Suitability of Use

Omron Companies shall not be responsible for conformity with any standards, codes or regulations which apply to the combination of the Product in the Buyer's application or use of the Product. At Buyer's request, Omron will provide applicable third party certification documents identifying ratings and limitations of use which apply to the Product. This information by itself is not sufficient for a complete determination of the suitability of the Product in combination with the end product, machine, system, or other application or use. Buyer shall be solely responsible for determining appropriateness of the particular Product with respect to Buyer's application, product or system. Buyer shall take application responsibility in all cases.

NEVER USE THE PRODUCT FOR AN APPLICATION INVOLVING SERIOUS RISK TO LIFE OR PROPERTY WITHOUT ENSURING THAT THE SYSTEM AS A WHOLE HAS BEEN DESIGNED TO ADDRESS THE RISKS, AND THAT THE OMRON PRODUCT(S) IS PROPERLY RATED AND INSTALLED FOR THE INTENDED USE WITHIN THE OVERALL EQUIPMENT OR SYSTEM.

### Programmable Products

Omron Companies shall not be responsible for the user's programming of a programmable Product, or any consequence thereof.

## Disclaimers

### Performance Data

Data presented in Omron Company websites, catalogs and other materials is provided as a guide for the user in determining suitability and does not constitute a warranty. It may represent the result of Omron's test conditions, and the user must correlate it to actual application requirements. Actual performance is subject to the Omron's Warranty and Limitations of Liability.

### Change in Specifications

Product specifications and accessories may be changed at any time based on improvements and other reasons. It is our practice to change part numbers when published ratings or features are changed, or when significant construction changes are made. However, some specifications of the Product may be changed without any notice. When in doubt, special part numbers may be assigned to fix or establish key specifications for your application. Please consult with your Omron's representative at any time to confirm actual specifications of purchased Product.

### Errors and Omissions

Information presented by Omron Companies has been checked and is believed to be accurate; however, no responsibility is assumed for clerical, typographical or proofreading errors or omissions.

# Safety Precautions





- **Symbols and the meanings for safety precautions described in this manual.**

In order for the product to be used safely, the following indications are used in this book to draw your attention to the cautions. The cautions with the indications describe the important contents for safety.

 <b>WARNING</b>	Indicates a potentially hazardous situation which, if not avoided, will result in minor or moderate injury, or may result in serious injury or death. Additionally there may be significant property damage.
--	---







 <b>CAUTION</b>	Indicates a potentially hazardous situation which, if not avoided, may result in minor or moderate injury or in property damage.
--	--

- **Meanings of Alert Symbols**

	General Prohibition Indicates general prohibitions, including warnings, for which there is no specific symbol.
	General Caution Indicates general cautions, including warnings, for which there is no specific symbol.
	Electrical Hazard Indicates the possible danger of electric shock under specific conditions.
	High Temperature Caution Indicates the possible danger of injury by high temperature under specific conditions.

● Alert statements in this Manual

 **WARNING**

<p>This product must be used according to this manual or Instruction sheet. Failure to observe this may result in impairment of functions and performance of the product.</p>	
<p>This product is not designed or rated for ensuring safety of persons. Do not use it for such purposes.</p>	
<p>Never connect the AC power supply with this product. When the AC power supply is connected, it causes the electric shock and a fire.</p>	
<p>When using equipment that is connected to an AC power source such as an AC adapter or PoE injector, use it within the rated voltage range. Usage with a voltage higher than what it is rated for may cause serious personal injury due to electric shock, or serious physical damage due to fire or equipment failure. Do not touch any part of the device while in operation, or immediately after turning OFF the power.</p>	
<p>Since camera that can be connected with this product emits a visible light that may have an adverse effect on the eyes, do not stare directly into the light emitted from the LED. If a specular object is used, take care not to allow reflected light enter your eyes.</p>	
<p>Please take external safety measures so that the system as a whole should be on the safe side even if a failure of a this product or an error due to an external factor occurred. An abnormal operation may result in serious accident.</p>	
<p>Please take fail-safe measures on your side in preparation for an abnormal signal due to signal conductor disconnection and/or momentary power interruption. An abnormal operation may result in a serious accident.</p>	

 **CAUTION**

<p>Danger of burns. Do not touch the case while the reader is running or just after power is turned OFF, since it remains extremely hot.</p>	
--	---

# Precautions for Safe Use

---

## Condition of the fitness of OMRON products

---

- Please do not use this product to directly or indirectly use to detect the human body for the purpose of ensuring the safety. In the same application, please use the safety sensor that is published on our sensor catalog.
- Omron products are designed and manufactured as general-purpose products for use in general industrial applications. They are not intended to be used in the following critical applications. If you are using Omron products in the following applications, Omron shall not provide any warranty for such Omron products, unless otherwise specifically agreed or unless the specific applications are intended by Omron.
  - (a) Applications with stringent safety requirements, including but not limited to nuclear power control equipment, combustion equipment, aerospace equipment, railway equipment, elevator/lift equipment, amusement park equipment, medical equipment, safety devices and other applications that could cause danger/harm to people's body and life
  - (b) Applications that require high reliability, including but not limited to supply systems for gas, water and electricity, etc., 24 hour continuous operating systems, financial settlement systems and other applications that handle rights and property
  - (c) Applications under severe condition or in severe environment, including but not limited to outdoor equipment, equipment exposed to chemical contamination, equipment exposed to electromagnetic interference and equipment exposed to vibration and shocks
  - (d) Applications under conditions and environment not described in specifications
- \*1. In addition to the applications listed from (a) to (d) above, Omron products (see definition) are not intended for use in vehicles designed human transport (including two wheel vehicles). Please do NOT use Omron products for vehicles designed human transport. Please contact the Omron sales staff for information on our automotive line of products.
- \*2. The above is part of the Terms and Conditions Agreement. Please use carefully read the contents of the guarantee and disclaimers described in our latest version of the catalog, data sheets and manuals.

## Installation Environment

---

- Do not use the product in areas where flammable or explosive gases are present.
- Be careful when unpacking this product, please. Injury may occur if the reader falls and strikes a person.
- Do not install the product close to high-voltage devices and power devices in order to secure the safety of operation and maintenance.
- Make sure to tighten all installation screws securely.

## Power Supply and Wiring

---

- Make sure to use the product with the power supply voltage specified by this manual.
- Do not connect AC power source to Sensor Controller. If connects AC power source, it might be a cause of the failure.
- Use the wire of a suitable size (AWG 16 to 12) according to the current consumption.
- Use a DC power supply with safety measures against high-voltage spikes (safety extra low-voltage circuits on the secondary side).
- Keep the power supply wires as short as possible.
- Do the following confirmations again before turning on the power supply.
  - Is the voltage and polarity of the power supply correct?
  - Is not the load of the output signal short-circuited?
  - Is the load current of the output signal appropriate?
  - Is not the mistake found in wiring?
- When using equipment that is connected to an AC power source such as an AC adapter or PoE injector, use it within the rated voltage range. Usage with a voltage higher than what it is rated for may cause serious personal injury due to electric shock, or serious physical damage due to fire or equipment failure. Do not touch any part of the device while in operation, or immediately after turning OFF the power.

## Ground

---

- Ensure that the power supply circuit of the unit is insulated from the internal circuit. Refer to the user manual.
- Check wiring again before turning on the unit.

## Security Measures

---

### ● Anti-Virus Protection

Install the latest commercial-quality antivirus software on the computer connected to the control system and maintain to keep the software up to date.

### ● Security Measures to Prevent Unauthorized Access

Take the following measures to prevent unauthorized access to our products:

- Install physical controls so that only authorized personnel can access control systems and equipment.
- Reduce connections to control systems and equipment via networks to prevent access from untrusted devices.
- Install firewalls to shut down unused communications ports and limit communications hosts and isolate control systems and equipment from the IT network.
- Use a virtual private network (VPN) for remote access to control systems and equipment.
- Adopt multifactor authentication to devices with remote access to control systems and equipment.
- Set strong passwords and change them frequently.
- Scan for viruses to ensure safety of USB drives or other external storage devices before connecting them to control systems and equipment.

## ● Data Input and Output Protection

Validate backups and ranges to cope with unintentional modification of input/output data to control systems and equipment.

- Check the scope of data.
- Check validity of backups and prepare data for restore in case of falsification or abnormalities.
- Safety design, such as emergency shutdown and fail-soft operation in case of data tampering or abnormalities.

## ● Data Recovery

Back up and update data periodically to prepare for data loss.

When using an intranet environment through a global address, connecting to an unauthorized terminal such as a SCADA, HMI or to an unauthorized server may result in network security issues such as spoofing and tampering.

You must take sufficient measures such as restricting access to the terminal, using a terminal equipped with a secure function, and locking the installation area by yourself.

When constructing an intranet, communication failure may occur due to cable disconnection or the influence of unauthorized network equipment. Take adequate measures, such as restricting physical access to network devices, by such means as locking the installation area.

When using a device equipped with the SD Memory Card function, there is a security risk that a third party may acquire, alter, or replace the files and data in the removable media by removing or unmounting the removable media. Please take sufficient measures, such as restricting physical access to the controller or taking appropriate management measures for removable media, by means of locking the installation area, entrance management, etc.

## ● Software

To prevent computer viruses, install antivirus software on the computer where you use this software. Make sure to keep the antivirus software updated.

Keep your computer's OS updated to avoid security risks caused by a vulnerability in the OS.

Always use the latest version of this software to add new features, increase operability, and enhance security.

Manage usernames and passwords for this software carefully to protect them from unauthorized uses.

Set up a firewall (e.g., disabling unused communication ports, limiting communication hosts, etc.) on a network for a control system and devices to separate them from other IT networks.

Make sure to connect to the control system inside the firewall.

Use a virtual private network (VPN) for remote access to a control system and devices from this software.



## Other

---

- Use only the cables designed specifically for the reader. Use of other products may result in malfunction or damage of the reader.
- Always turn OFF the power of the reader and peripheral devices before connecting or disconnecting a cable. Connecting the cable with power supplied may result in damage of the reader or peripheral devices.
- Do not apply torsion stress to the cable. It may damage the cable.
- Secure the minimum bending radius of the cable. Otherwise the cable may be damaged.
- Do not attempt to dismantle, repair, or modify the product.
- Should you notice any abnormalities, immediately stop use, turn OFF the power supply, and contact your OMRON representative.
- While the power is ON or immediately after the power is turned OFF, the case are still hot. Do not touch the case.
- The reader must be used with the special mounting bracket (-AM0 or -AM1: sold separately), or the reader may generate heat.
- When disposing of the product, treat it as an industrial waste.
- Do not drop the product nor apply excessive vibration or shock to the product. Doing so may cause malfunction or burning.
- When controlling stages and robots using the read results (axis movement output based on calibration and alignment measurement), always take fail-safe measures within the stage and robot systems, such as checking whether the data obtained from the read results is within the range of movement of the stages and robots.

# Precautions for Correct Use

---

## Installation and Storage Sites

---

Install and store the product in a location that meets the following conditions:

- Surrounding temperature of 0 to +40°C (-50 to +75°C in storage)
- No rapid changes in temperature (place where dew does not form)
- Relative humidity of between 5 to 85%
- No presence of corrosive or flammable gases
- Place free of dust, salts and iron particles
- Place free of vibration and shock
- Place out of direct sunlight
- Place where it will not come into contact with water, oils or chemicals
- Place not affected by strong electro-magnetic waves
- Place not near to high-voltage, or high-power equipment

## Ambient Temperature

---

- For good heat dissipation, keep the distance.
- Do not install the product immediately above significant heat sources, such as heaters, transformers, or large-capacity resistors.
- Do not let the ambient temperature exceed an operating temperature range.
- Provide a forced-air fan cooling or air conditioning if the ambient temperature is near the upper range of operating temperature range so that the ambient temperature never exceeds the upper range of operating temperature range.

## Noise Resistance

---

- Do not install the product in a cabinet containing high-voltage equipment.
- Do not install the reader within 200 mm of power cables.

## Component Installation and Handling

---

- Turning OFF the Power  
When a message is displayed indicating that a task is in progress, do not turn OFF the power. Doing so causes the data in the memory to be corrupted, resulting in the product not operating properly upon the next start-up.  
When turns OFF, conform the followings proceedings have completed. and then operate again.
  - When saves using the reader:  
Confirm the save processing is completed and next operation is possible.
  - When saves using communication command:  
Intended command is completed.
- Setting of Power Source  
The power source need to be supplied from DC power source apparatus which is taken a save ultra-low voltage circuit: to protect high voltage.

## Maintenance

---

- Turn OFF the power and ensure the safety before maintenance.
- Clean the lens with a lens-cleaning cloth or air brush.
- Lightly wipe off dirt with a soft cloth.
- Do not use thinners or benzene.
- To ensure safe access for operation and maintenance, separate the reader as much as possible from high-voltage equipment and power machinery.

## Communication with High-Order Device

---

- After confirming that this product is started up, communicate with the high-order device. When this product has started up, an indefinite signal may be output from the high-order interface. To avoid this problem, clear the receiving buffer of your device at initial operations.

## Other

---

- For symbols with a highly gloss surface, reading errors may occur because of regular reflection of the LED light. If this occurs, provide a skew angle of 15° against the symbol.
- Do not look into the light emitted from the LED directly. When this products has started up, the LED flashes.
- Under an environment with high humidity and rapid changes in temperature, the inside of the front plate might fog up. When the read rates lower due to the fog, leave the device with turned it on for 30 minutes to 2 hours. Use it again after checking there is no fog on the front plate.

## LED Safety

---

- This product is classified into the IEC 62471-1:2006 Risk-Exempt Group. However, this product does emit a strong visible light that may have an adverse effect on the eyes. Do not stare directly into the light emitted from the LED. If a specular object is used, take care not to allow reflected light to enter your eyes.

# Regulations and Standards

---

## Using Product Outside Japan

---

This regulation applies to MicroHAWK readers and peripheral devices.

If you export (or provide a non-resident with) this product or a part of this product that falls under the category of goods (or technologies) specified by the Foreign Exchange and Foreign Trade Control Law as those which require permission or approval for export, you must obtain permission or approval or service transaction permission) pursuant to the law.

## Conformance to EC/EU Directives and UK Legislation

---

This regulation applies to MicroHAWK code readers and peripheral devices.

- This product is in compliance with all applicable directives: 2014/30/EU, 2014/35/EU, 2011/65/EU, and UK Legislation 2016 No. 1091 Electromagnetic Compatibility Regulations 2016.
- EMC-related performance of the OMRON devices will vary depending on the configuration, wiring, and other conditions of the equipment or control panel on which the OMRON devices are installed. The customer must, therefore, perform the final check to confirm that devices and the overall machine conform to EMC standards.

## Conformance to UL Standards

---

This regulation applies to reader and peripheral devices.

This product complies with UL Standards.

- UL60950-1 2<sup>nd</sup>-edition, 2014 (Class III)

## Korean Radio Regulation (KC)

---

사용자안내문

이 기기는 업무용 환경에서 사용할 목적으로 적합성평가를 받은 기기로서 가정용 환경에서 사용하는 경우 전파간섭의 우려가 있습니다.

### Guide for Users

This equipment has been evaluated for conformity in a commercial environment. When used in a residential environment, it may cause radio interference.

## Radio Frequency Interference Requirements: FCC



This equipment has been tested for compliance with FCC (Federal Communications Commission) requirements and has been found to conform to applicable FCC standards. To comply with FCC RF exposure compliance requirements, this device must not be co-located with or operate in conjunction with any other antenna or transmitter. Changes or modifications not expressly approved by the party responsible for compliance could void the user's authority to operate the equipment.

### Model V420-F Class A Statement

**NOTE:** This equipment has been tested and found to comply with the limits for a Class A digital device, pursuant to part 15 of the FCC Rules. These limits are designed to provide reasonable protection against harmful interference when the equipment is operated in a commercial environment. This equipment generates, uses, and can radiate radio frequency energy and, if not installed and used in accordance with the instruction manual, may cause harmful interference to radio communications. Operation of this equipment in a residential area is likely to cause harmful interference in which case the user will be required to correct the interference at his own expense.

### Models V320-F, V330-F, and V430-F Class B Statement

**NOTE:** This equipment has been tested and found to comply with the limits for a Class B digital device, pursuant to part 15 of the FCC Rules. These limits are designed to provide reasonable protection against harmful interference in a residential installation. This equipment generates, uses and can radiate radio frequency energy and, if not installed and used in accordance with the instructions, may cause harmful interference to radio communications. However, there is no guarantee that interference will not occur in a particular installation. If this equipment does cause harmful interference to radio or television reception, which can be determined by turning the equipment off and on, the user is encouraged to try to correct the interference by one or more of the following measures:

- Reorient or relocate the receiving antenna.
- Increase the separation between the equipment and receiver.
- Connect the equipment into an outlet on a circuit different from that to which the receiver is connected.
- Consult the dealer or an experienced radio/TV technician for help.

## Radio Frequency Interference Requirements: Canada

This device complies with Industry Canada ICES-003. Operation is subject to the following two conditions: (1) This device may not cause harmful interference, and (2) this device must accept any interference received, including interference that may cause undesired operation. Cet appareil est conforme à la norme ICES-003 d'Industrie Canada. Son fonctionnement est soumis aux deux conditions suivantes: (1) l'appareil ne doit pas produire de brouillage, et (2) l'utilisateur de l'appareil doit accepter tout brouillage radioélectrique subi, même si le brouillage est susceptible d'en compromettre le fonctionnement.

Model V420-F: This Class A digital apparatus complies with Canadian ICES-003.

Cet appareil numérique de la classe A est conforme à la norme NMB-003 du Canada.

Models V320-F, V330-F and V430-F : This Class B digital apparatus complies with Canadian ICES-003. Cet appareil numérique de la classe B est conforme à la norme NMB-003 du Canada.

# Revision History

---

The manual's part number and revision appear on the first and last pages.

<b>Man.No.</b>	<b>Z432-E-06</b>
----------------	------------------

↑  
Revision

Revision	Date	Revised Content
01	November 2019	First publication.
02	January 2020	Updated front window, diffuser, and polarizer accessory part numbers.
03	May 2020	General improvements.
04	December 2020	Added Advanced Decoding Parameters content. General improvements.
05	August 2022	Security Measures updates.
06	November 2022	UKCA compliance information added.

# CONTENTS

---

<b>Terms and Conditions Agreement .....</b>	<b>3</b>
<b>Safety Precautions .....</b>	<b>5</b>
<b>Precautions for Safe Use .....</b>	<b>7</b>
<b>Precautions for Correct Use.....</b>	<b>9</b>
<b>Regulations and Standards.....</b>	<b>11</b>
<b>Revision History .....</b>	<b>13</b>

## Section 1 Overview

---

<b>1-1 Introduction.....</b>	<b>1-2</b>
<b>1-2 Splash Screen.....</b>	<b>1-3</b>
<b>1-3 Navigation Bar .....</b>	<b>1-4</b>
<b>1-4 Flash Icon.....</b>	<b>1-5</b>
<b>1-5 Help Icon .....</b>	<b>1-6</b>
<b>1-6 Application Settings Icon.....</b>	<b>1-7</b>
<b>1-7 Left Panel .....</b>	<b>1-8</b>
<b>1-8 Right Panel.....</b>	<b>1-10</b>
<b>1-9 Image Area .....</b>	<b>1-11</b>
<b>1-10 Guided Tour .....</b>	<b>1-16</b>

## Section 2 Quick Start

---

<b>2-2 MicroHAWK and WebLink Quick Start.....</b>	<b>2-2</b>
2-1-1 Check Hardware and Connect the System .....	2-2
2-1-2 Check MicroHAWK Status LEDs .....	2-6
2-1-3 Mount and Position the Reader .....	2-7
2-1-4 Install WebLink Drivers (V320-F and V420-F) .....	2-8
2-1-5 Connect to WebLink. ....	2-9
2-1-6 Configure Daisy Chain (If Required by Application) .....	2-12
2-1-7 Explore the Start View .....	2-19
2-1-8 Create a New Setup or Load an Existing Setup .....	2-20
2-1-9 Explore the Setup View .....	2-21
2-1-10 Configure Read Cycle Settings .....	2-22
2-1-11 Configure Acquire Settings .....	2-24
2-1-12 Configure Symbology and Decode Settings .....	2-27
2-1-13 Format Output and Configure Match String .....	2-28
2-1-14 Configure Output 1, 2, and 3 Settings .....	2-30
2-1-15 Run the Application .....	2-31



## Section 3 Start

---

3-1 Overview.....	3-2
3-2 Assisted Setup.....	3-4
3-3 Reader Information.....	3-5
3-4 Setup Buttons .....	3-6

## Section 4 Setup

---

4-1 Autocalibration .....	4-2
4-2 Cycle .....	4-4
4-3 Acquire .....	4-6
4-4 Decode.....	4-9
4-5 Match String.....	4-11
4-6 Format Output.....	4-15
4-7 Outputs.....	4-19
4-8 Configuration Database .....	4-21
4-9 Favorites.....	4-27

## Section 5 Run

---

5-1 Counts .....	5-2
5-2 Rate.....	5-3
5-3 Read Time .....	5-4
5-4 Output Data .....	5-5
5-5 Image History.....	5-6

## Section 6 Application Settings

---

6-1 Application Settings Menu.....	6-2
6-2 Save .....	6-3
6-3 New .....	6-4
6-4 Load.....	6-5
6-5 Advanced .....	6-6
6-6 Language.....	6-7
6-7 Terminal.....	6-8
6-8 Beeper .....	6-9
6-9 Guided Tour .....	6-10
6-10 Image Storage.....	6-11
6-11 Restore Default Settings .....	6-18
6-12 Activate Account Management .....	6-19
6-13 Enable USB Drive Mode.....	6-27
6-14 About WebLink .....	6-28

## Section 7 Terminal

---

7-1 Send .....	7-2
7-2 Find .....	7-3
7-3 Filters .....	7-4

## Section 8 Advanced Settings

---

8-1 Introduction .....	8-2
8-2 Camera Setup .....	8-3
8-3 Communications .....	8-4
8-4 Read Cycle .....	8-7
8-5 Symbologies .....	8-8
8-6 I/O .....	8-14
8-7 Symbol Quality .....	8-32
8-8 Match String .....	8-33
8-9 Diagnostics .....	8-34
8-10 Image Storage .....	8-35
8-11 Configuration Database .....	8-36
8-12 Differences from Default .....	8-37

## Appendices

---

Appendix A General Specifications .....	A-1
Appendix B Electrical Specifications .....	B-1
Appendix C Serial Commands .....	C-1
Appendix D Communications .....	D-1
Appendix E Calibration .....	E-1
Appendix F Read Cycle .....	F-1
Appendix G Symbologies .....	G-1
Appendix H I/O Parameters .....	H-1
Appendix I Symbol Quality .....	I-1
Appendix J Matchcode .....	J-1
Appendix K Camera and IP Setup .....	K-1
Appendix L Configuration Database .....	L-1
Appendix M Utilities .....	M-1
Appendix N Output Format .....	N-1
Appendix O Communications Protocol .....	O-1
Appendix P ASCII Table .....	P-1
Appendix Q Glossary of Terms .....	Q-1
Appendix R Q & A .....	R-1
Appendix S Optics and Lighting Accessory Kit Installation .....	S-1
Appendix T TCP/UDP and General Port Usage .....	T-1



# 1

## Overview

---

This section provides a general overview of the **WebLink** user interface.

---

1-1	Introduction .....	1-2
1-2	Splash Screen .....	1-3
1-3	Navigation Bar .....	1-4
1-4	Flash Icon .....	1-5
1-5	Help Icon .....	1-6
1-6	Application Settings Icon .....	1-7
1-7	Left Panel .....	1-8
1-8	Right Panel .....	1-10
1-9	Image Area .....	1-11
1-10	Guided Tour .....	1-16

# 1-1 Introduction

---

The browser-based **WebLink** interface enables quick and easy configuration and testing of **MicroHAWK V320-F, V330-F, V420-F, V430-F** readers without the need to install or access files on a host system.

WebLink is reliable, lightweight, and operating-system-independent without compromising the power and depth of its tool set.

WebLink offers novice users an intuitive way to connect, configure, monitor, and troubleshoot a MicroHAWK reader, and provides the power and flexibility expected by advanced users.

## 1-2 Splash Screen

After you open a browser and **enter your reader's IP address**, the first thing you will see is the **splash screen**, a portion of which is shown below. You will also see a progress bar as your WebLink session starts.

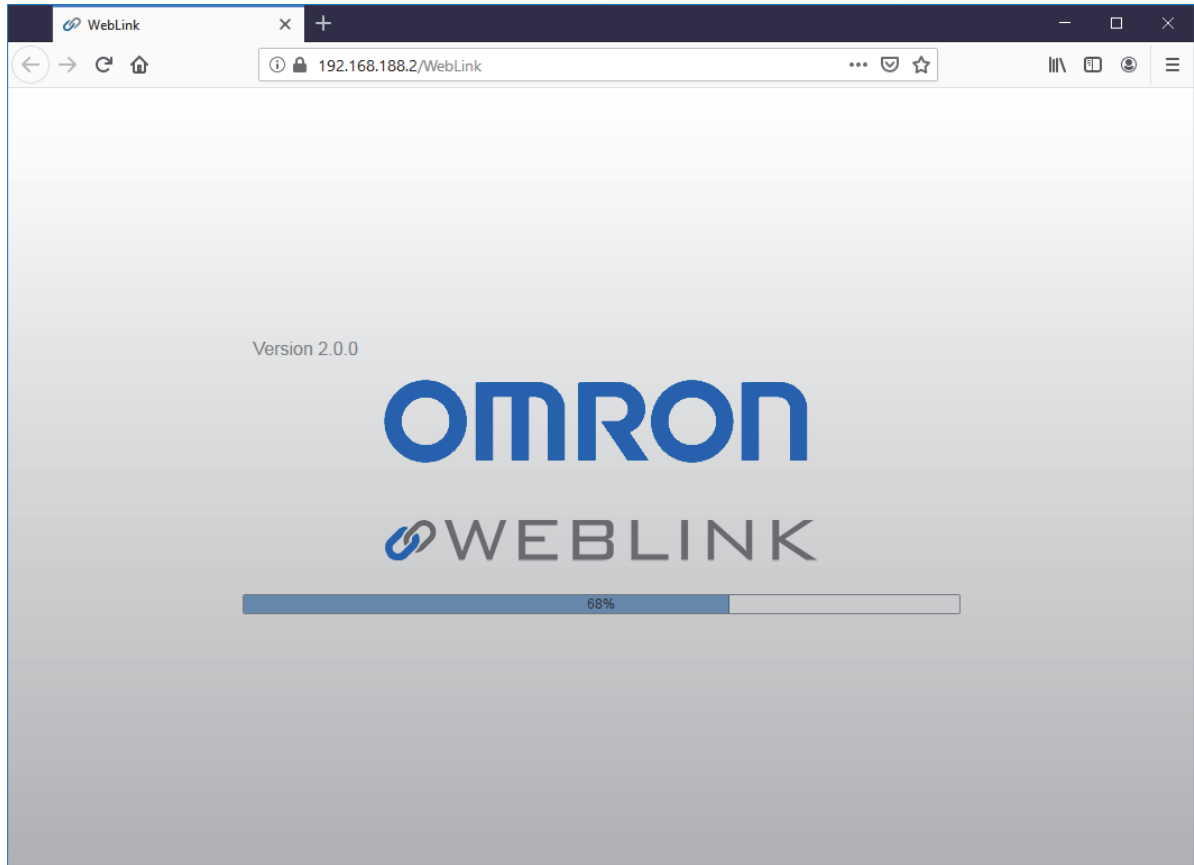

1

## 1-3 Navigation Bar

---

The **navigation bar** at the top of the WebLink interface features buttons for three primary views: **Start**, **Setup**, and **Run**.

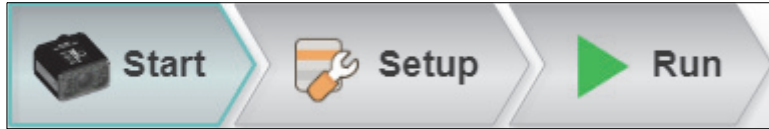

## 1-4 Flash Icon

---

The **flash icon** allows you to save current settings to the reader for reboot. When the current reader settings match those saved in flash memory, the disk icon changes from **red** to **blue**.

### 1-4-1 Save to Flash Memory



### 1-4-2 Saved to Flash Memory





## 1-5 Help Icon

---

The **help icon** is located to the right of the flash icon. Click this icon to open **WebLink Help**.

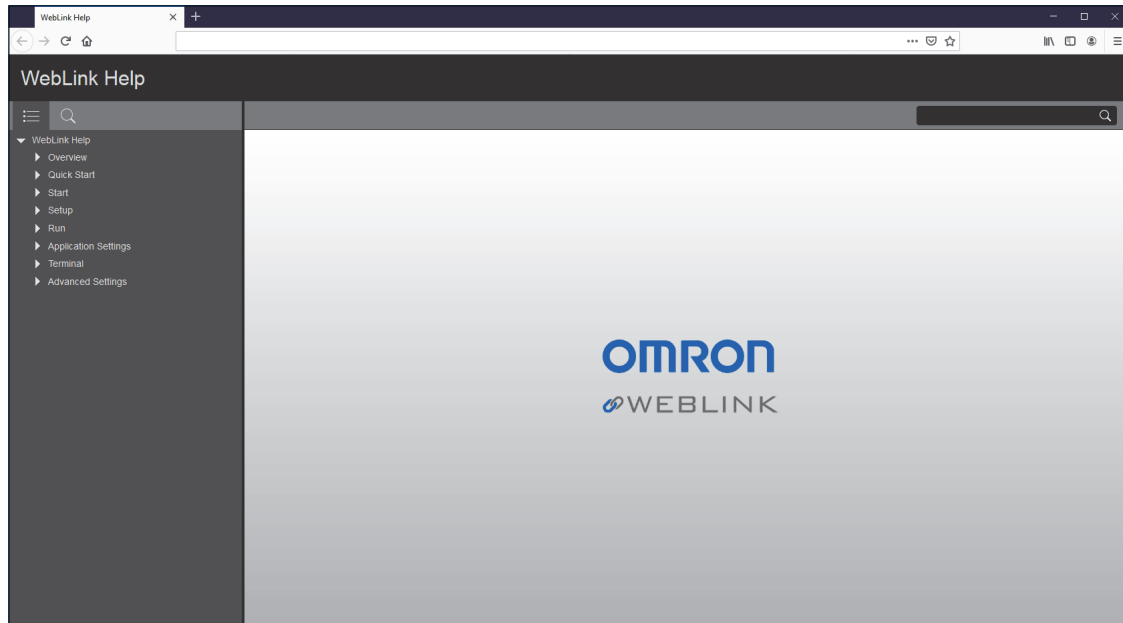

# 1-6 Application Settings Icon

Click the **gear icon** to the right of the help icon to open the **Application Settings** menu.



1

## 1-6-1 Application Settings Menu

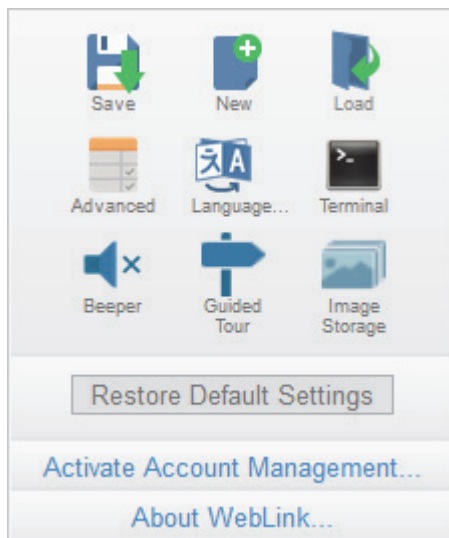

**Note:** The **Enable USB Drive Mode** option only appears when you are using a V420-F, which supports USB connectivity.

## 1-7 Left Panel

The area to the left of the **Image Area** is different depending on whether you are in the **Start** or **Setup** view. (In the **Run** view, the Image Area expands and the left panel is not present.)

### 1-7-1 Left Panel in Start View

In the **Start** view, the left panel shows your reader's **user-defined name**, **IP address**, **License Options**, **Reader Model**, **Serial Number**, **MAC ID**, **Firmware version**, **WebLink version**, **Sensor**, **Optics**, **Decoder**, and **Speed**.

**Note:** The information in this area is selectable so that you can copy it to a clipboard.

**Note:** The **user-defined name** must be **19** characters or fewer.

The left panel in the Start view also contains buttons for **Assisted Setup**, **Create a New Setup**, and **Load a Setup**.

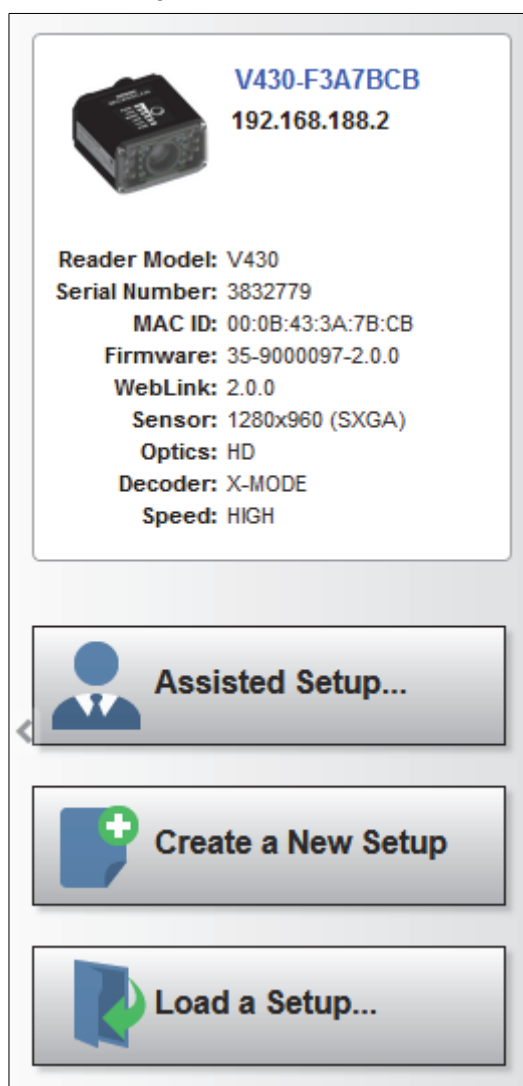

## 1-7-2 Left Panel in Setup View

In the **Setup** view, the left panel contains the majority of WebLink's configuration tools: **Cycle**, which allows you to set the trigger mode; **Acquire**, which allows you to set the camera's exposure and gain; **Decode**, which allows you to select which code types are required in your application; **Match String**, which allows you to set the match code mode, wildcard, text output, new master, and match string database; **Format Output**, which allows you to determine the ways in which barcode data can be formatted before it is output as a data string; **Outputs**, which allows you to determine output conditions, the output mode, the pulse width, and the output state (normally open or normally closed); and **Favorites**, which allows you to define the commands you use most frequently and gives you quick access to their command parameters.

The screenshot shows the left panel of the WebLink Setup View, titled "Read Cycle Sequence". It contains several configuration sections:

- Cycle Triggered**: Includes a green checkmark, a pulse icon, and settings for Serial Trigger Character (<SP>), Trigger Delay (0 μs), Timeout after (500 ms), and Look for (1 symbols).
- Acquire**: Includes a green checkmark, a camera icon, Exposure (1299 μs), Gain (0 %), and a distance of 4.5 Inches. Enhance is Disabled.
- Decode**: Includes a green checkmark and a list of barcode types: Data Matrix, QR code, Code 128, Code 39, Code 93, I2of5, UPC, PDF417, Micro PDF, DataBar-14, DataBar Limited, DataBar Extended, and Micro QR Code. A gear icon is at the bottom right.
- Match String**: Includes a toggle switch set to Off.
- Format Output**: Includes a toggle switch set to Off, and checkboxes for Preamble (<CR>) and Postamble (<CR><LF>).
- Outputs**: Includes a pulse icon and three output conditions: 1: Mismatch or No Read, 2: Mismatch or No Read, 3: Mismatch or No Read.
- Favorites**: Includes a star icon and two favorite commands: Light Source and Outer LED Only.



# 1-9 Image Area

The **Image Area** is the main focus of WebLink. This area allows you to see what currently falls within the reader's field of view, and offers several image control tools.

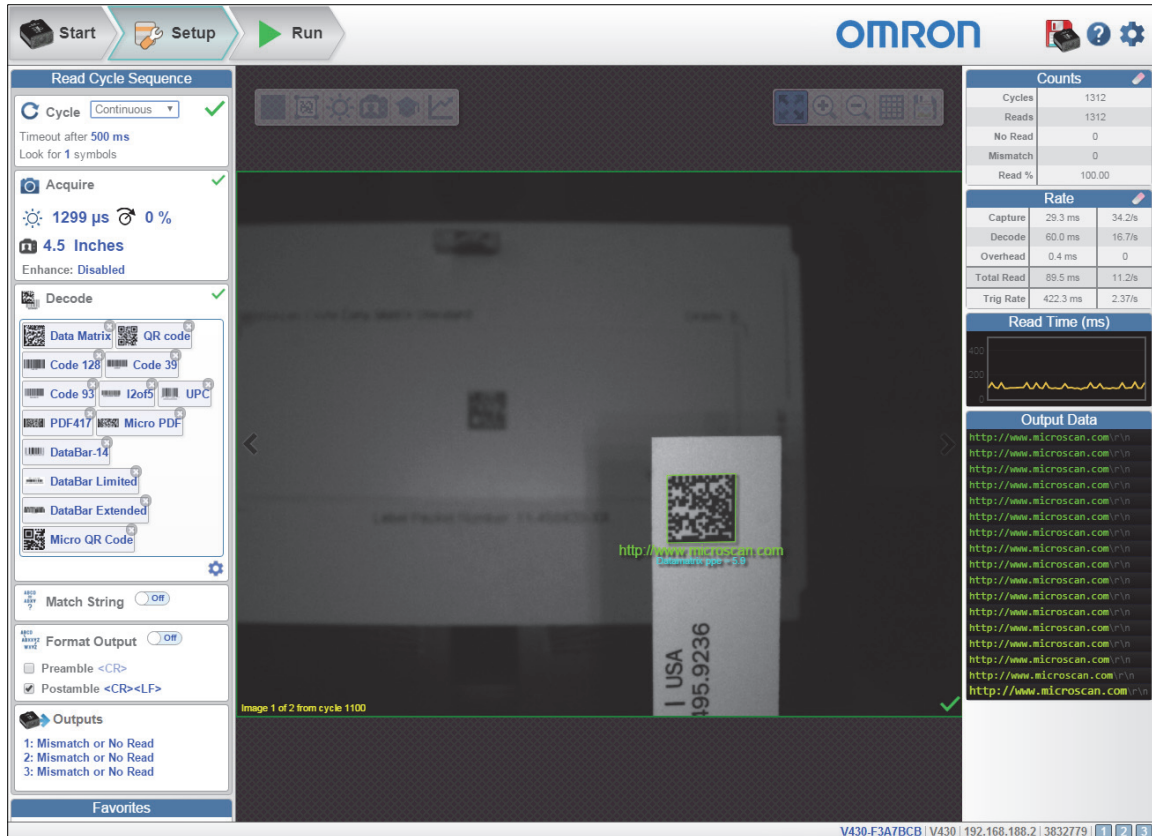

## 1-9-1 Device Control Toolbar

The **Device Control** buttons are a convenient way to enable and disable multiple triggering methods and image processing settings in the camera directly from the **Image Area**.

### Start Read Cycle

Starts the camera's read cycle.



### Stop Read Cycle

Stops the camera's read cycle.



## Send a Serial Trigger to the Reader

Sends a **Serial Trigger** to the camera.



## Set Window of Interest

Allows you to define the **Window of Interest** directly in the Image Area interface.

**Note:** When using an SXGA reader with Auto Photometry enabled, the Window of Interest cannot be set to a width less than 640.



## Auto Photometry On

Turns **Auto Photometry** on. The camera's Auto Photometry settings defined in the **Acquire** section of the **Setup** interface are applied to the image when Auto Photometry is on.

When the reader is in **Triggered** mode and Auto Photometry is on, the best **Exposure** and **Gain** settings are determined for the next captured image. Auto Photometry functions differently in Triggered mode than in **Continuous** mode or **Presentation** mode: when Auto Photometry is on in Triggered mode, it is only a one-time setting. Exposure and Gain are not adjusted dynamically with each trigger as they would be in Continuous mode or Presentation mode.

When the reader is in Continuous mode or Presentation mode and you click the Auto Photometry button, the reader maintains optimal self-adjusting photometry and focus parameters until you click the button again to turn Auto Photometry off. Symbol data is decoded and symbol information is transmitted repeatedly as long as the symbol is within the reader's field of view and read range.



## Auto Photometry Off

Turns **Auto Photometry** off.



## Autofocus On

Turns **Autofocus** on. The camera's Autofocus settings defined in the **Acquire** section of the **Setup** interface are applied to the image when Autofocus is on.





# Autofocus Off

Turns **Autofocus** off.



# Train

Performs a full symbol calibration to find the best Focus, Exposure, and Gain, and saves relevant information regarding the decoded target symbol to allow greater decodability of similar symbols.

You will see the **Determine parameter ranges...** and **Training Complete** messages shown in the examples below during the Train operation.

**Note:** The Train operation will un-optimize the system once an image is processed, but you can optimize the system again after a Train operation.

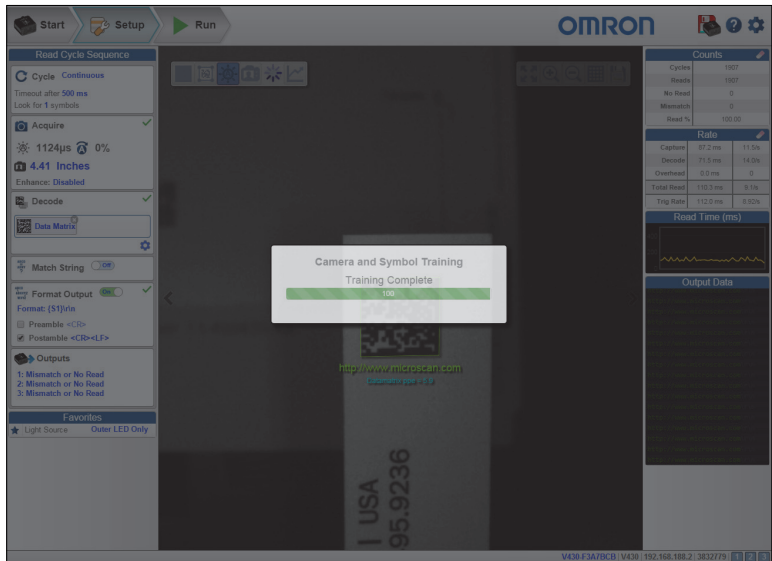
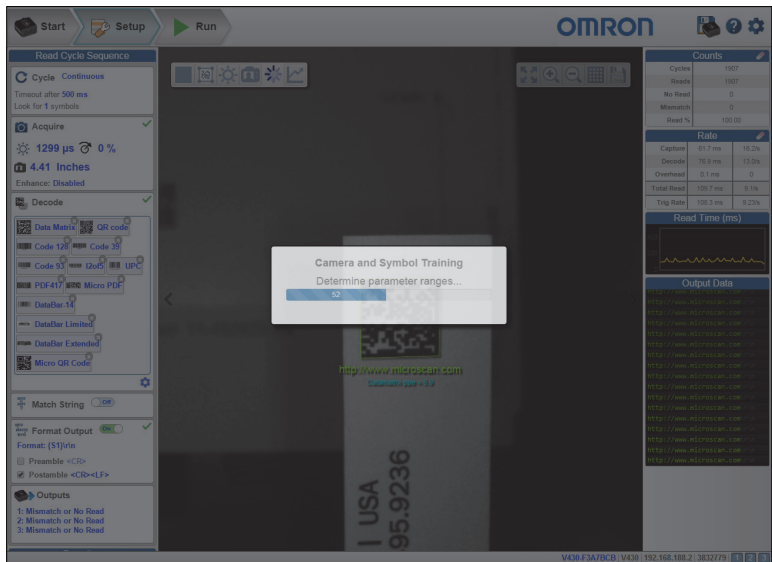

1

**Note:** The **Train** button only appears in the **Device Control Toolbar** when the **Read Cycle** is configured to look for **only 1 symbol**.

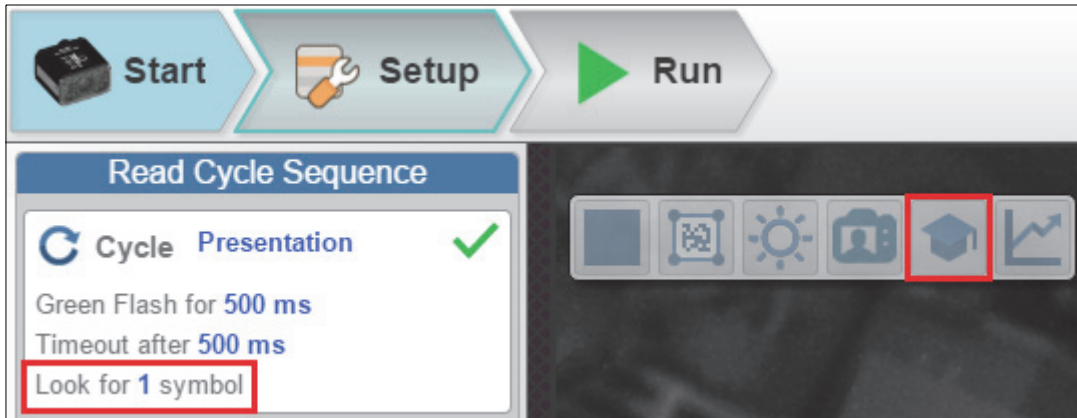

When the **Read Cycle** is looking for **2 or more symbols**, the **Train** button appears.

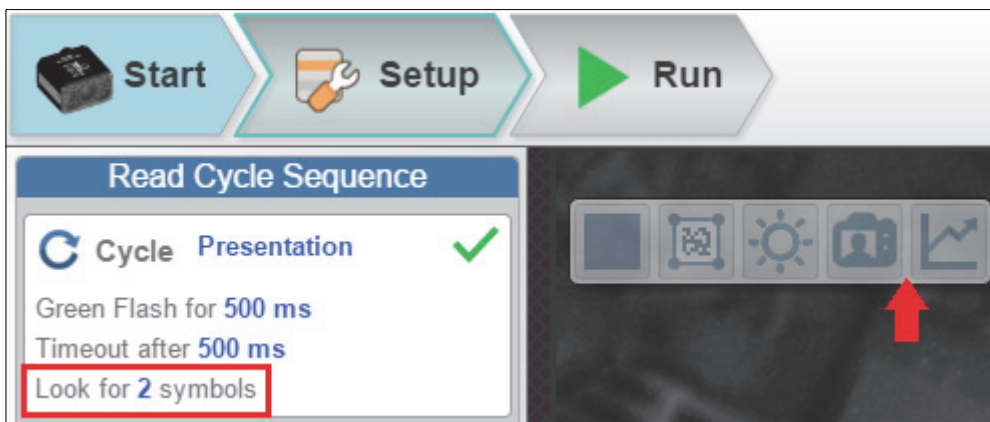

## Optimize

Saves relevant information about the target symbol, allowing the subsequent symbols to be processed more quickly and consistently.

The reader has three optimization states: **un-optimized**, **optimizing**, and **optimized**.

When the reader is in the **un-optimized** state and the Optimize button is clicked, the reader enters the **optimizing** state until a symbol is decoded or until the Optimize button is clicked again to deactivate the optimizing state. When a symbol is decoded during the optimizing state, the reader enters the **optimized** state.

**Note:** A Train operation can reduce decode performance. It will un-optimize the system when an image is processed. You can re-optimize the system after a Train operation.



## 1-9-2 Image Control Toolbar

### Fit Image to Window

Fits the captured image to the Image Area window.



### Zoom In

Zooms in on the desired area of the captured image.



### Zoom Out

Zooms out and decreases the size of the captured image.



**Note:** You can also zoom in and out by scrolling up or down with your mouse, and you can move the image around by clicking and dragging.

### Show All Images Used in Read Cycle

Shows all the images that have been captured during the most recent read cycle.



### Save Current Image

Allows you to save the current captured image to the location of your choice on your PC.



# 1-10 Guided Tour

The **Guided Tour** is a multi-step tutorial that explains the functions of the various areas of the WebLink user interface.

## 1-10-1 Start View

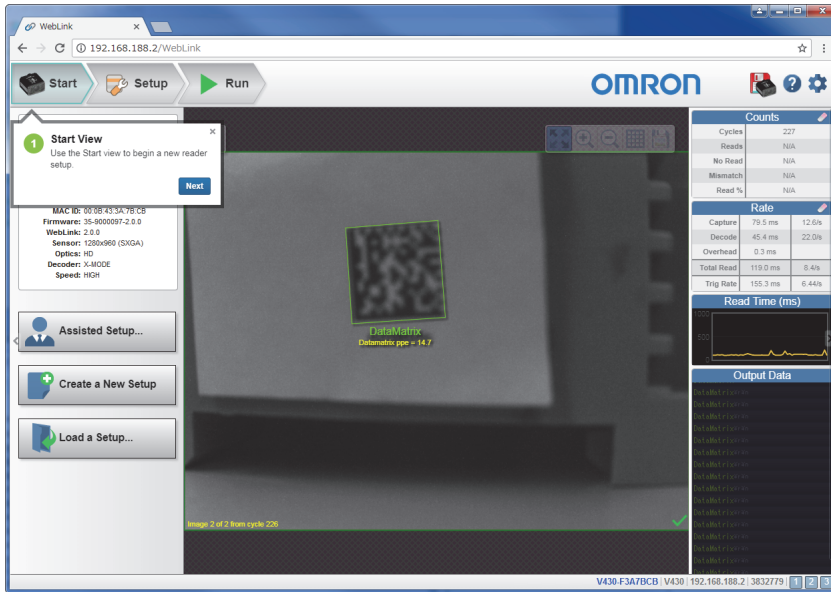

## 1-10-2 Reader Info

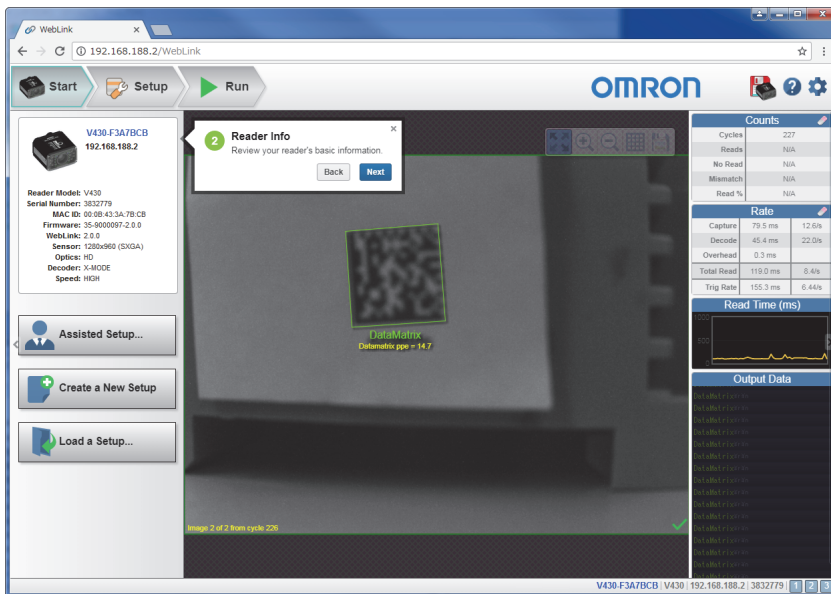

### 1-10-3 Assisted Setup

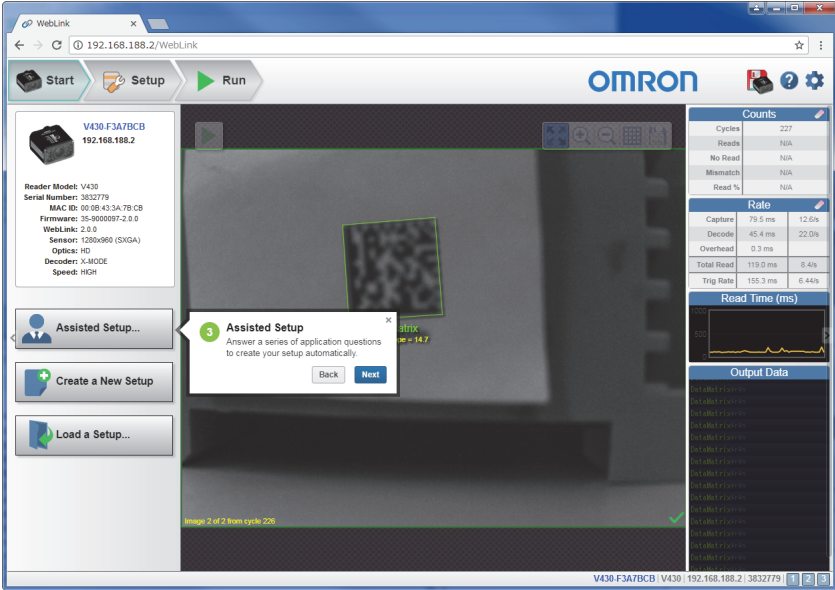

1

### 1-10-4 New Setup

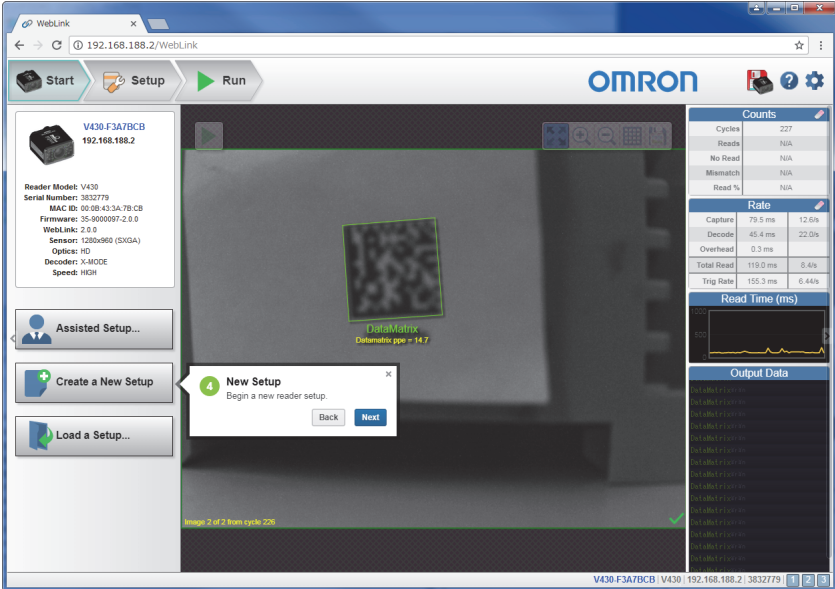

## 1-10-5 Load Setup

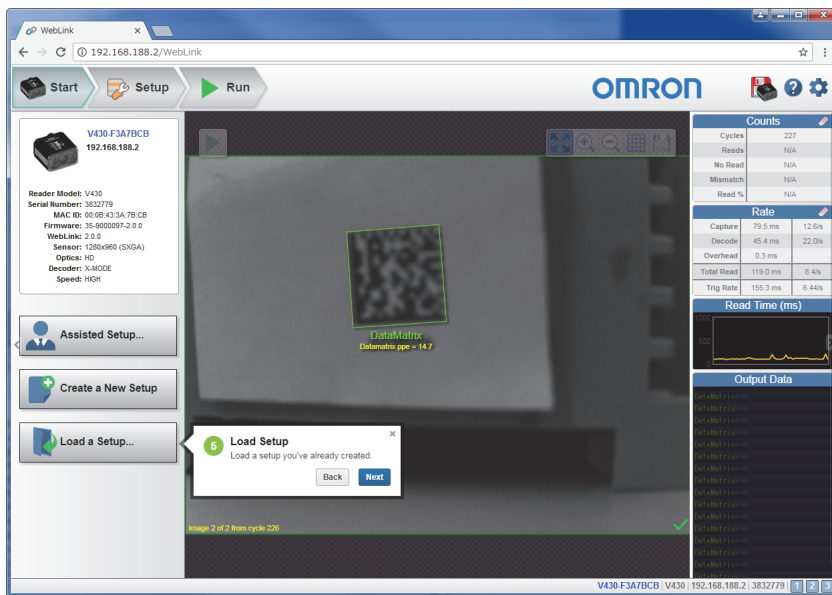

## 1-10-6 Image Area

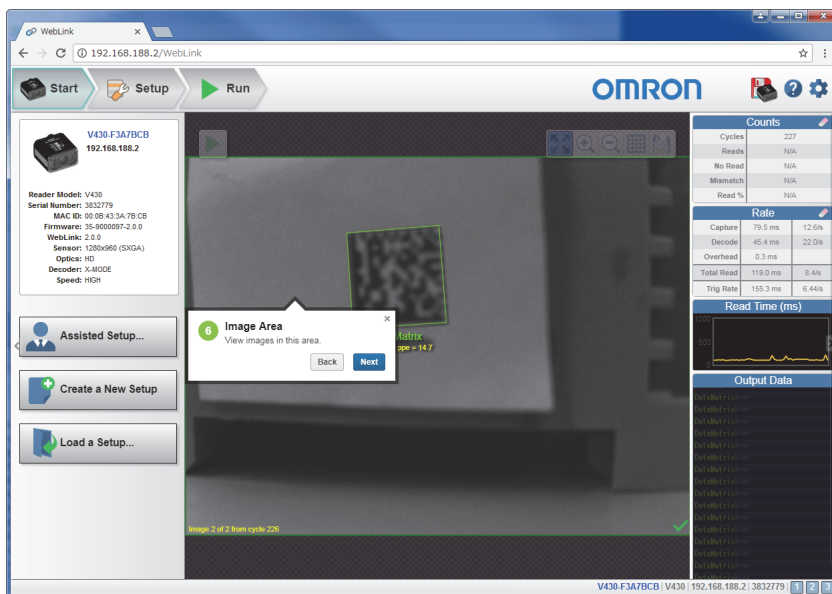



### 1-10-7 Control Toolbar

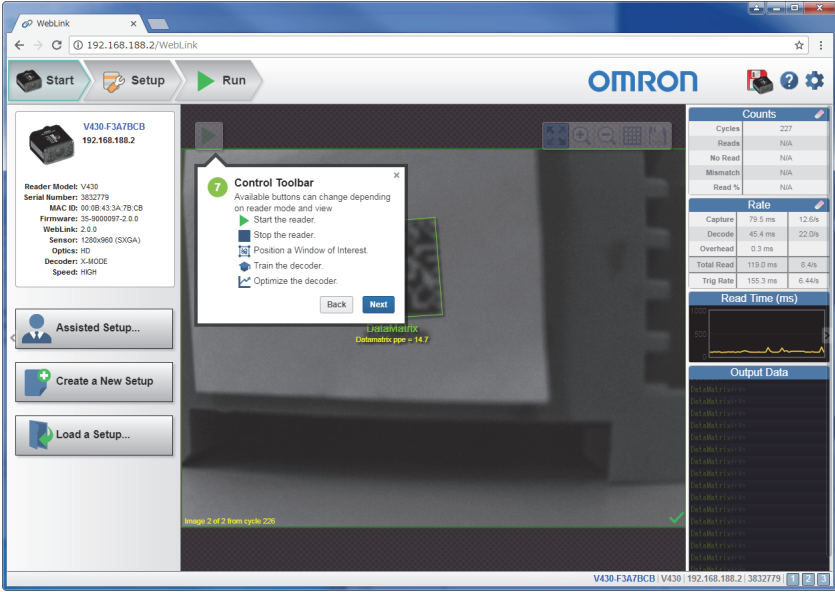

1

### 1-10-8 Image Toolbar

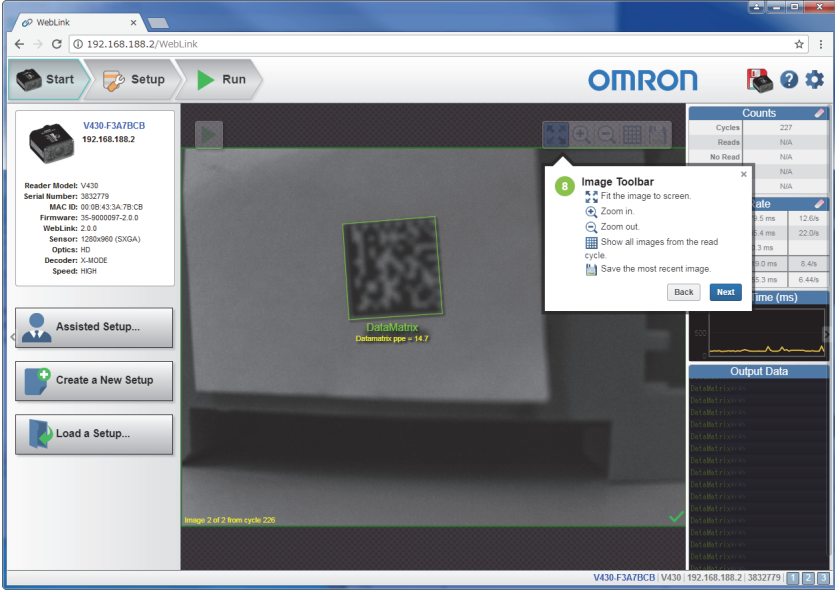

## 1-10-9 Save Settings to Reader

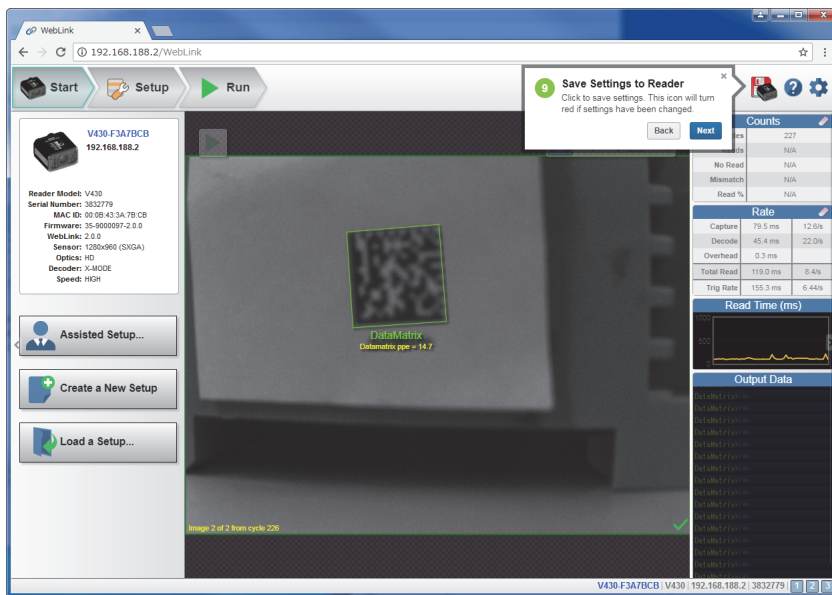

## 1-10-10 Help

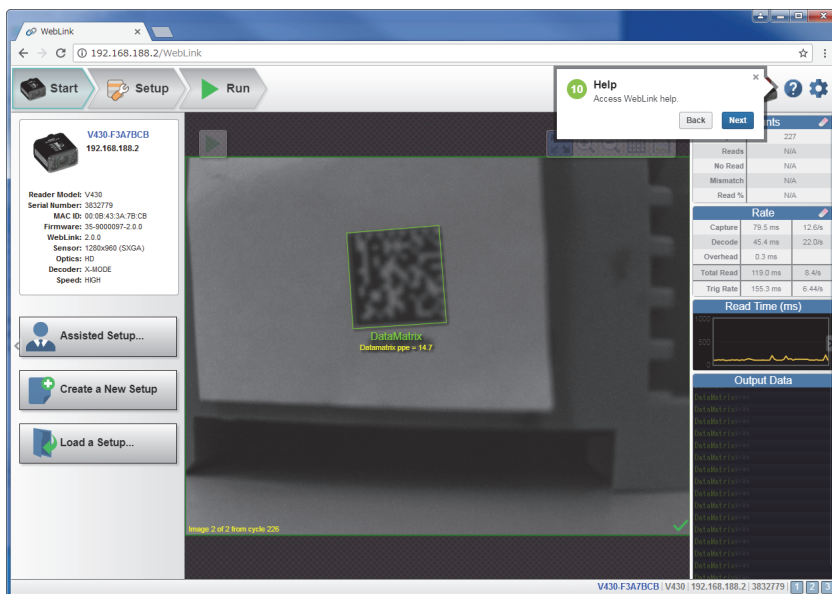



## 1-10-11 Settings

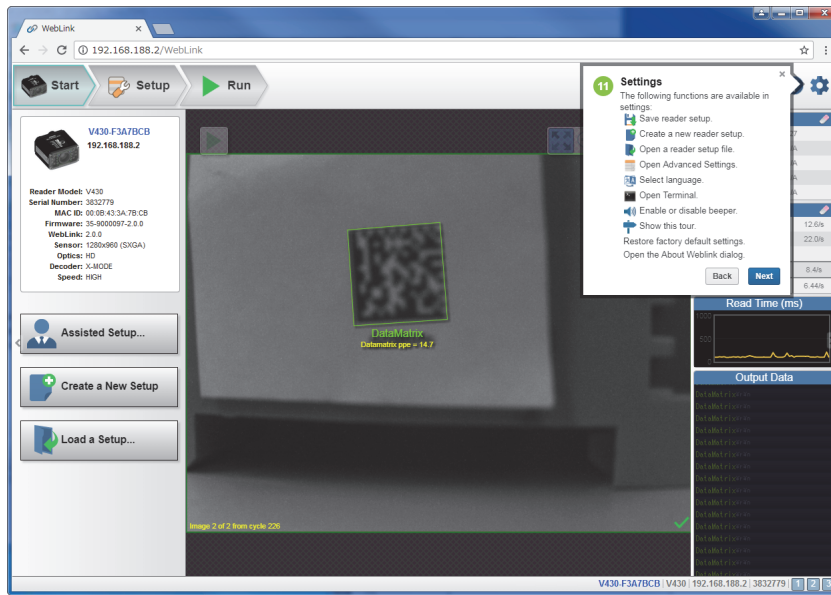

## 1-10-12 Counts

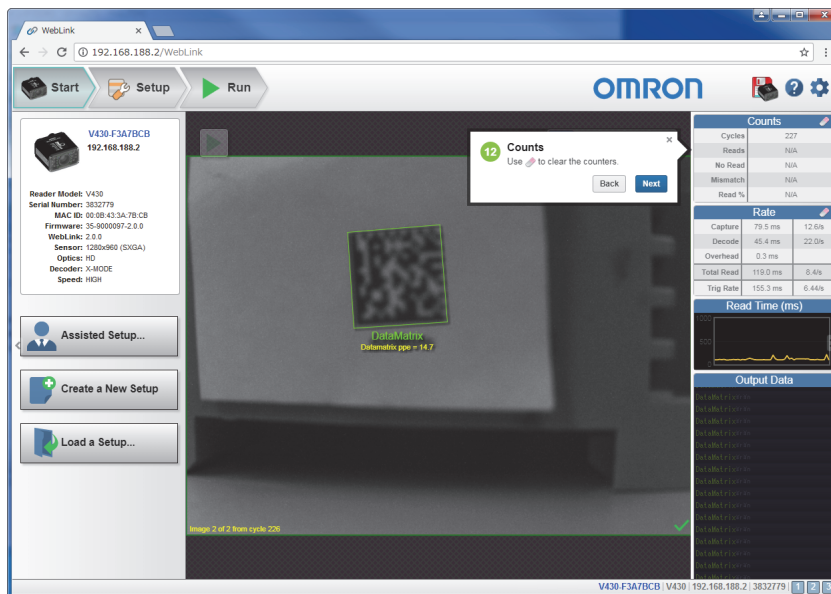

## 1-10-13 Rate

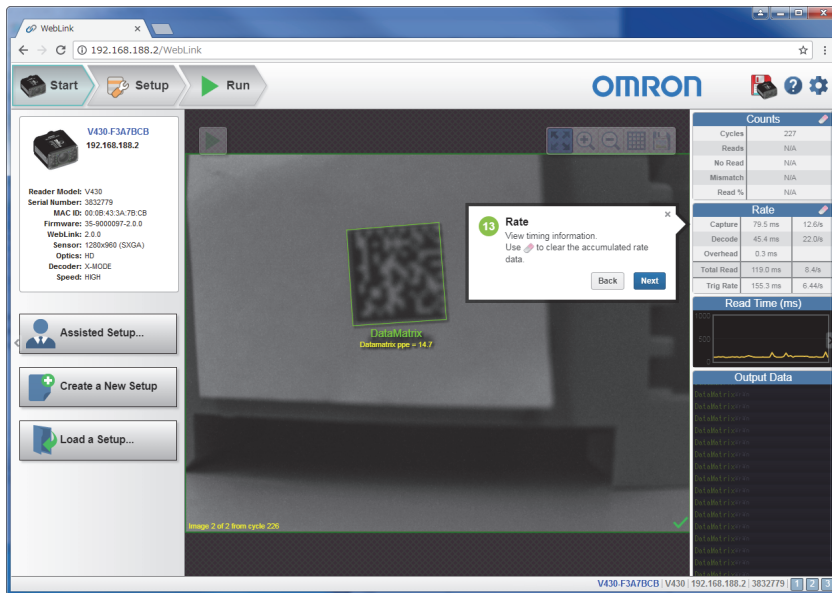

## 1-10-14 Read Time

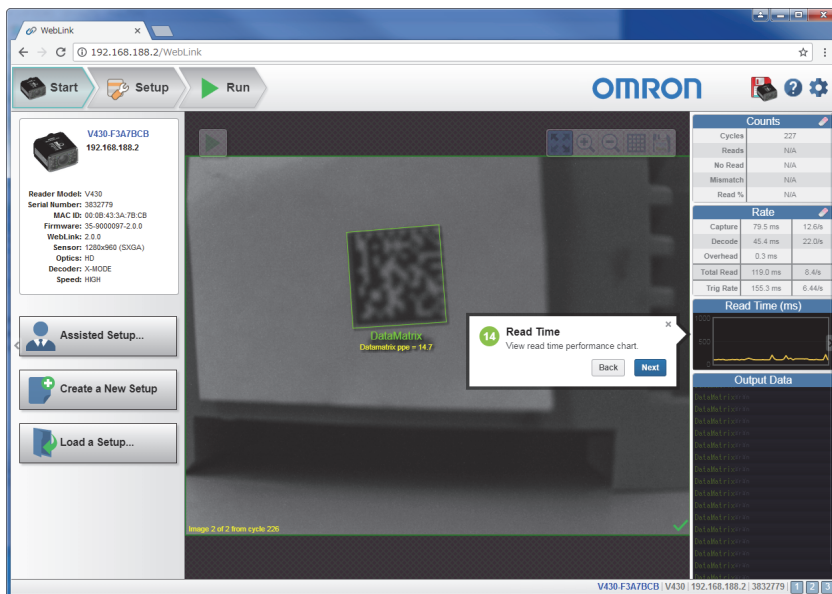

# 1-10-15 Output Data

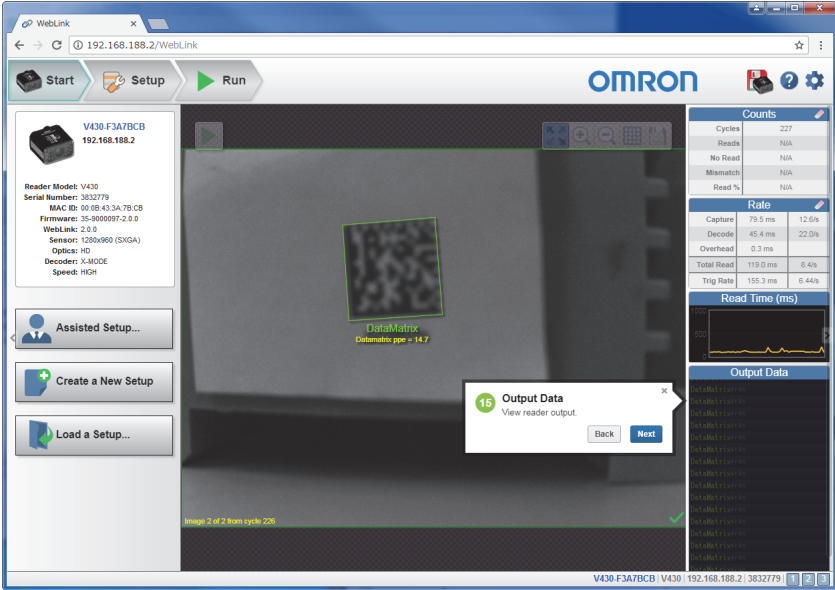

1

# 1-10-16 Setup View

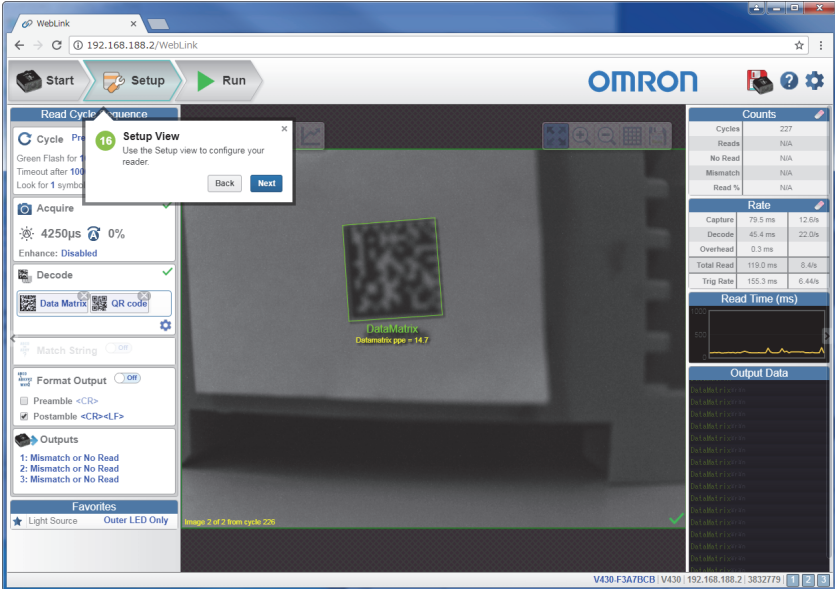

## 1-10-17 Read Cycle Step

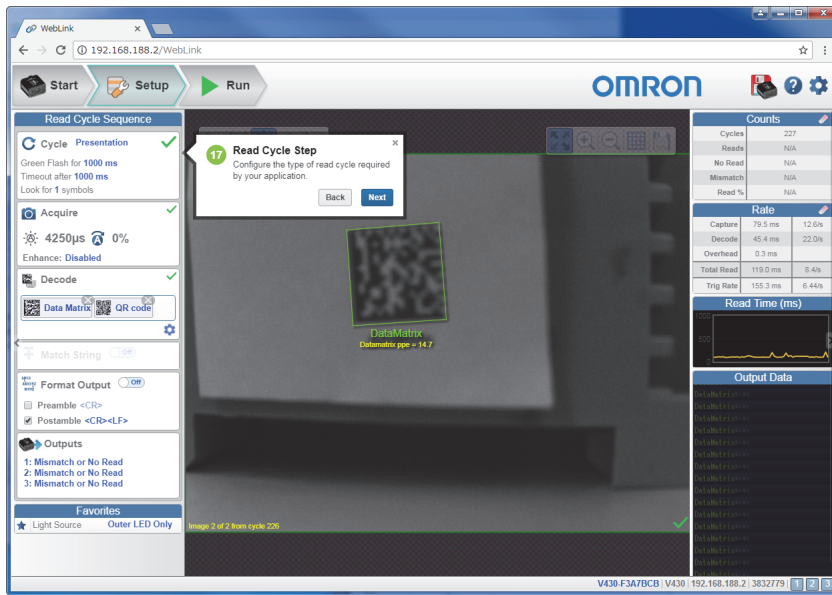

## 1-10-18 Acquire Step

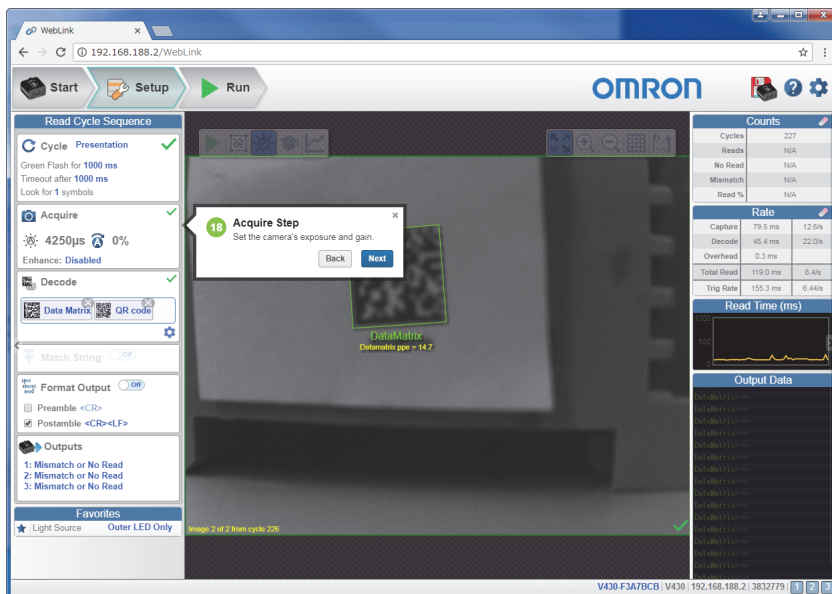

### 1-10-19 Decode Step

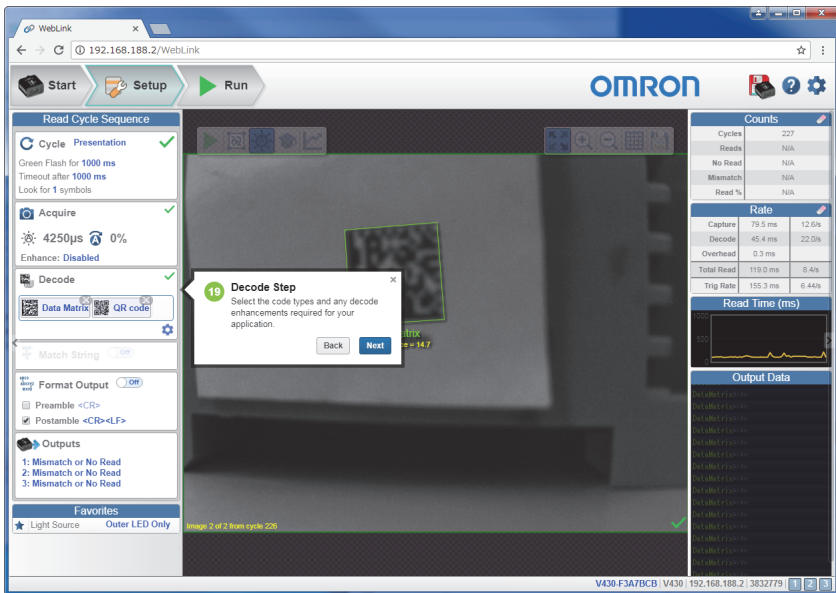

1

### 1-10-20 Match Step

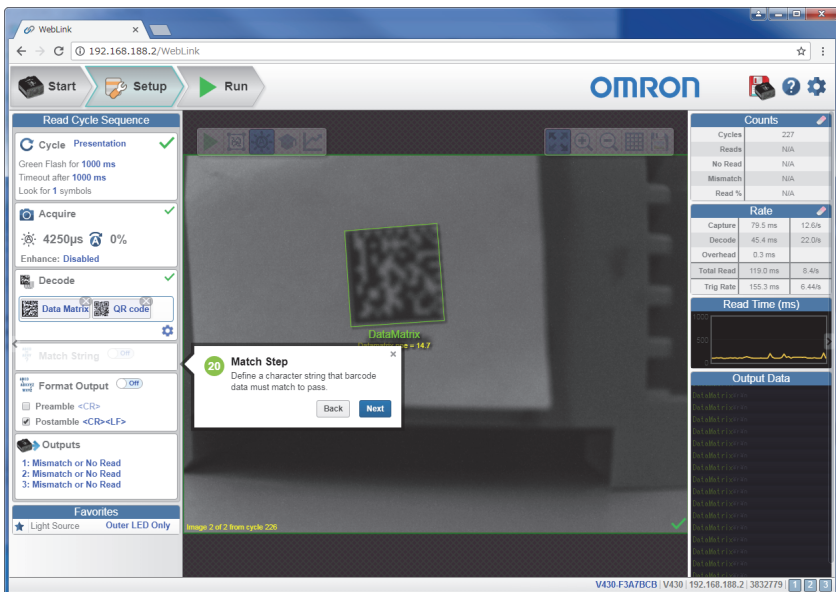

## 1-10-21 Format Output Step

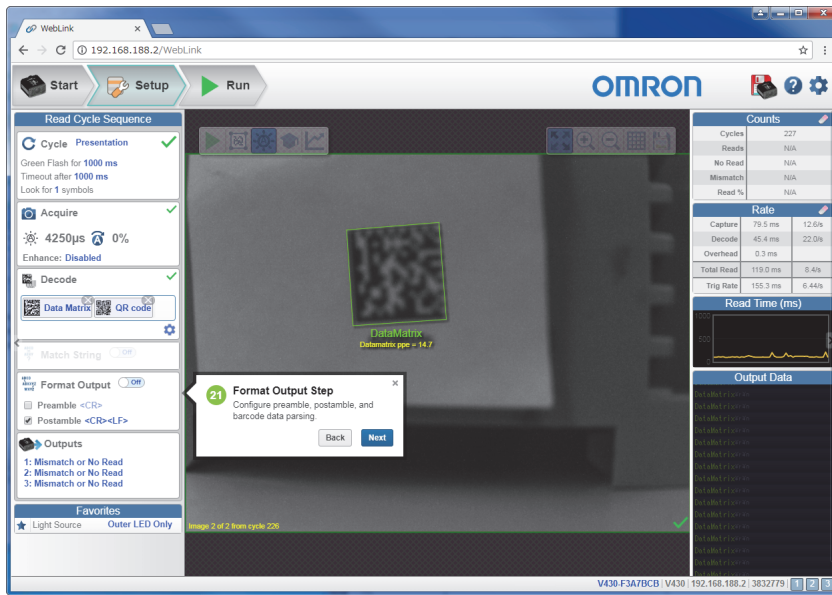

## 1-10-22 Output Step

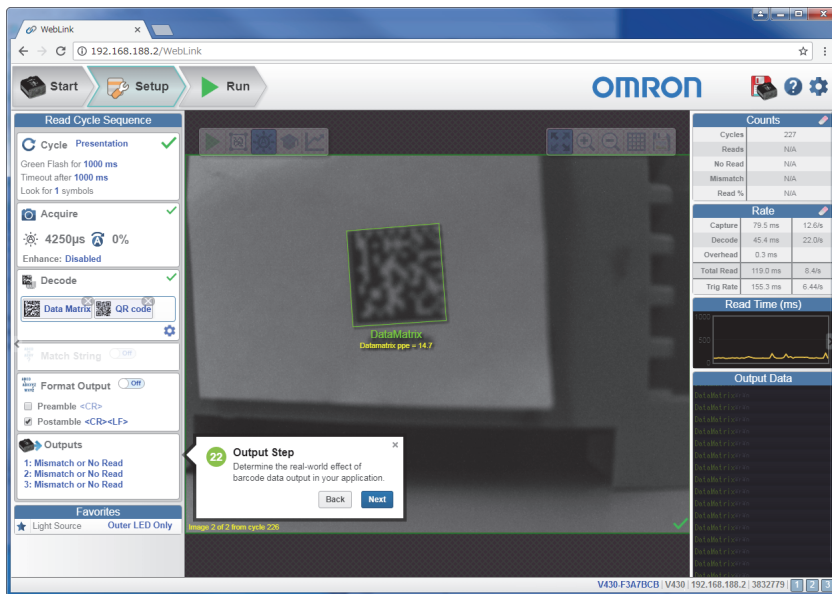



### 1-10-23 Favorites



1

### 1-10-24 Run View

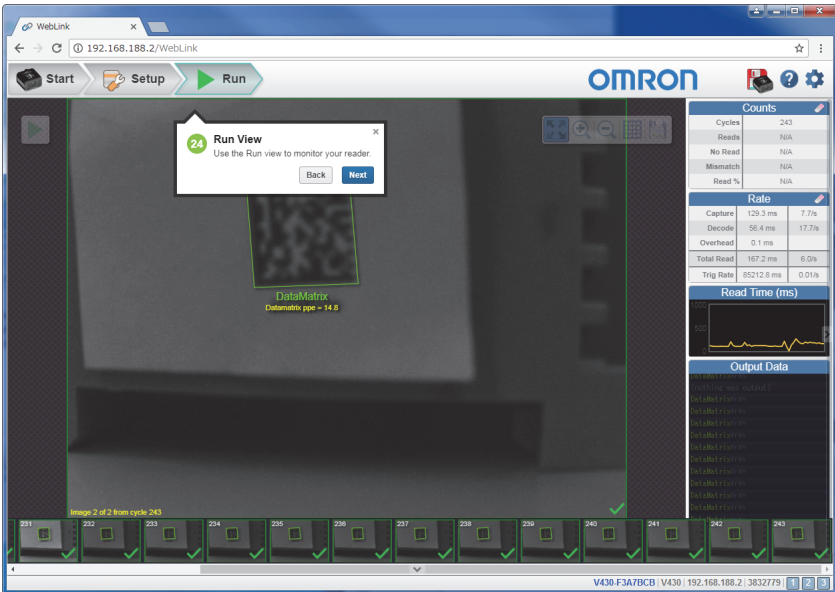

## 1-10-25 Filmstrip

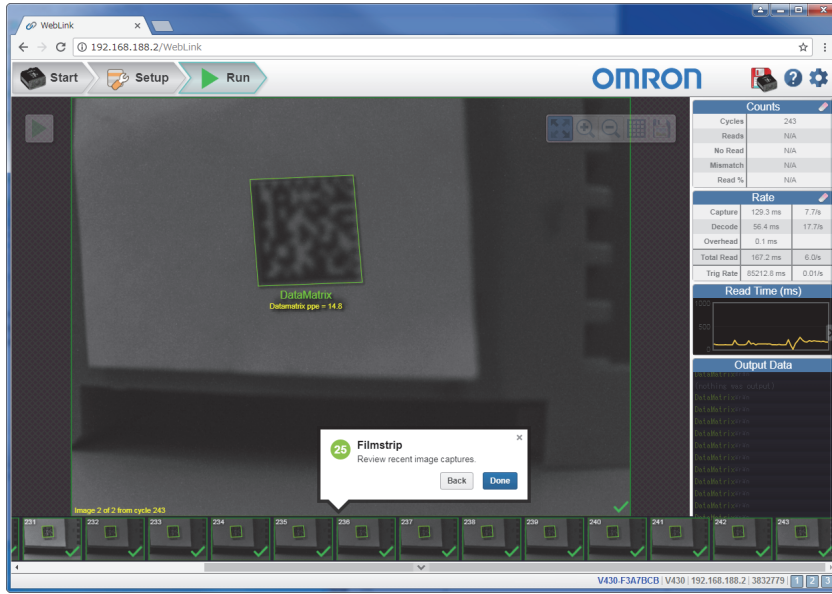



# 2

## Quick Start

This section is designed to get your **MicroHAWK** reader up and running quickly using **WebLink**. Following these steps will allow you to get a sense of the reader's capabilities and to test sample symbols.

---

<b>2-1</b>	<b>MicroHAWK and WebLink Quick Start</b>	<b>2-2</b>
2-1-1	Check Hardware and Connect the System	2-2
2-1-2	Check MicroHAWK Status LEDs	2-6
2-1-3	Mount and Position the Reader	2-7
2-1-4	Install WebLink Drivers (V320-F and V420-F)	2-8
2-1-5	Connect to WebLink	2-9
2-1-6	Configure Daisy Chain (If Required by Application)	2-12
2-1-7	Explore the Start View	2-19
2-1-8	Create a New Setup or Load an Existing Setup	2-20
2-1-9	Explore the Setup View	2-21
2-1-10	Configure Read Cycle Settings	2-22
2-1-11	Configure Acquire Settings	2-24
2-1-12	Configure Symbology and Decode Settings	2-27
2-1-13	Format Output and Configure Match String	2-28
2-1-14	Configure Output 1, 2, and 3 Settings	2-30
2-1-15	Run the Application	2-31

# 2-1 MicroHAWK and WebLink Quick Start

There are two ways to configure and test MicroHAWK readers:

- Omron Microscan's browser-based WebLink user interface, which enables you to access, configure, and test your reader without having to install software or access files on a host system (recommended);
- Serial commands that can be sent from the Terminal in WebLink or from another terminal program.

**Important:** The following hardware configurations are examples only. Real-world application configurations may vary considerably from those shown below.

## 2-1-1 Check Hardware and Connect the System

### MicroHAWK V320-F Configuration Options

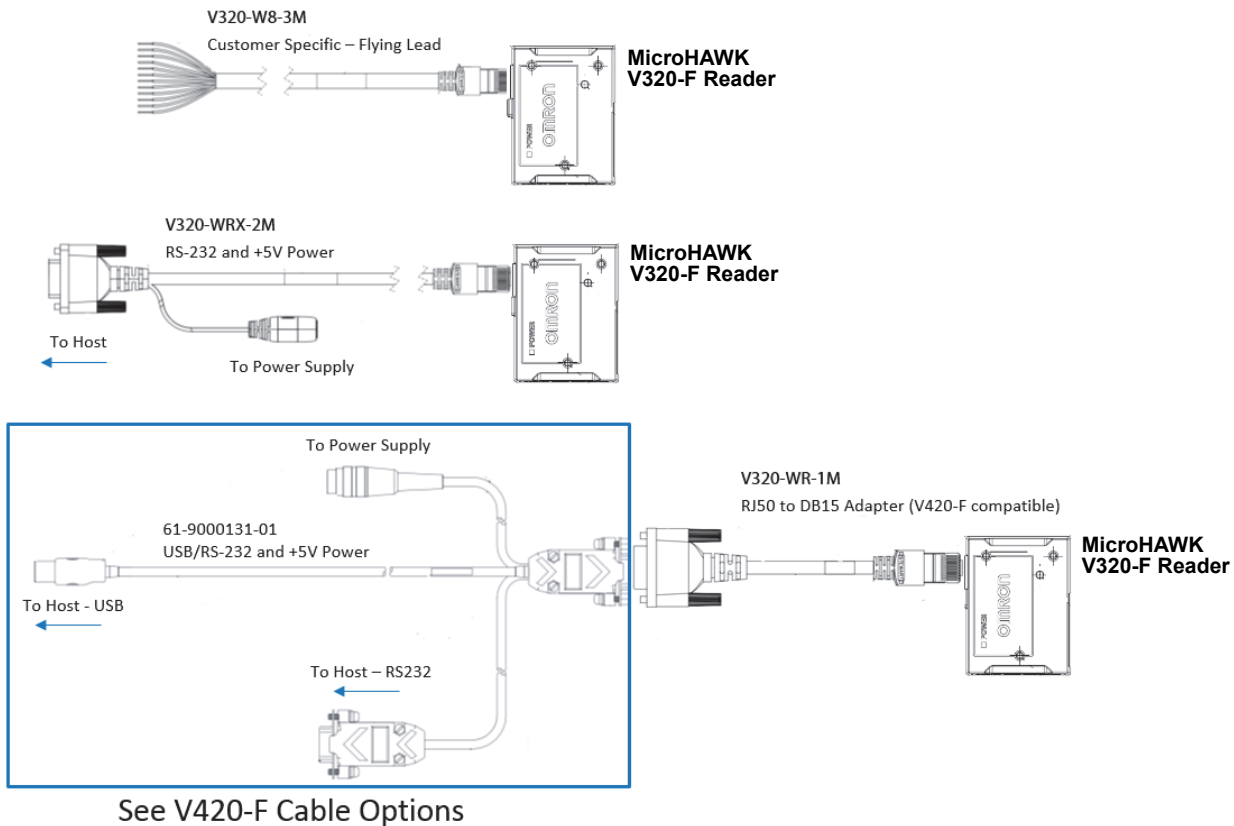

### MicroHAWK V330-F Configuration Options

The V330-F supports Power over Ethernet (POE), allowing you to power and communicate with the device from a single cable. The V330-F is considered a Class 0 PD (Powered Device) and will operate when connected to appropriate PoE PSE (Power Sourcing Equipment). The PSE will either provide power on an unused data pair (Alternative B) or on the data pair (Alternative A) which depends on the PSE. The V330-F supports both Mode A and Mode B per the PoE standard, IEEE802.3af.

When the V330-F is connected to the Cat5E cable, it will automatically present a Powered Device (PD) signature to the Power Sourcing Equipment (PSE), or PoE Mid-Span Equipment, when requested. The equipment will then recognize that a powered device is connected to that line and will supply power.

Omron recommends that you contact your network or IT administrator for further configuration details. You can connect to a non-PoE network using standard off-the-shelf PoE injectors, or network switches with PoE ports.

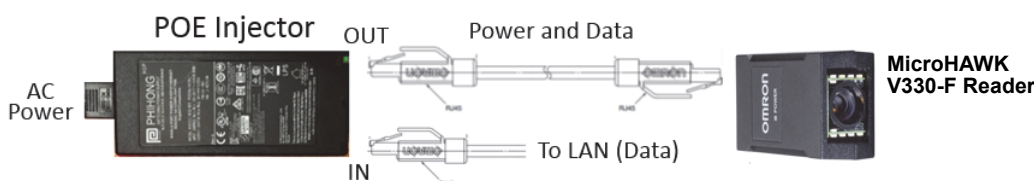

## MicroHAWK V420-F Configuration Options

- Mount the reader securely in its stand (not supplied).
- Mount the reader as required by the application.
- Connect the integrated corner-exit cable to the MicroHAWK V420-F.
- Connect the accessory USB cable to the integrated corner-exit cable.
- Connect the USB Type A side of the USB cable to the host.
- Connect the power cable into the power source.

### V420-F with DB15 to BUS Power USB Type A

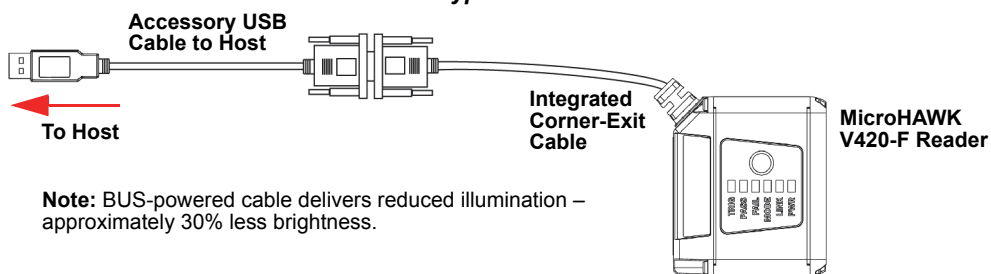

### V420-F with DB15 to Ext. Power/USB Type A

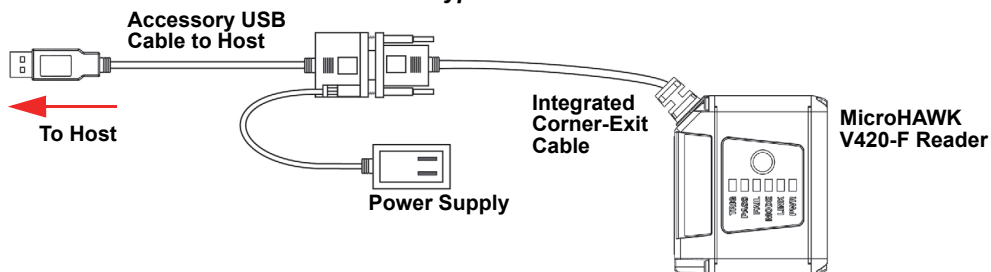

### V420-F with DB15 to Ext. Power/RS-232

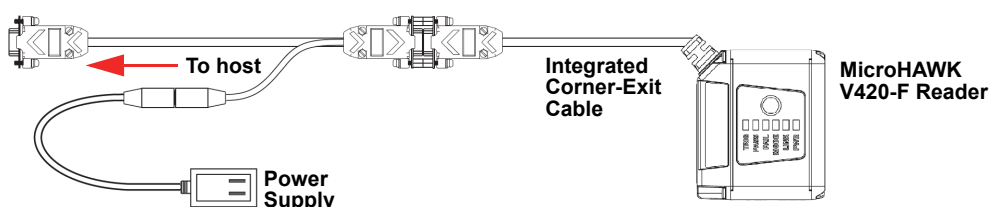

### V420-F with DB15 to Ext. Power/USB, I/O

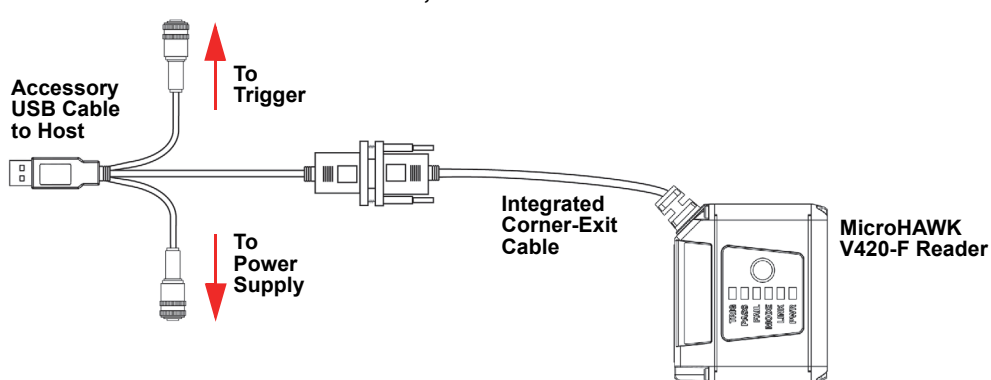

### V420-F with DB15 to USB/RS-232, Triggered

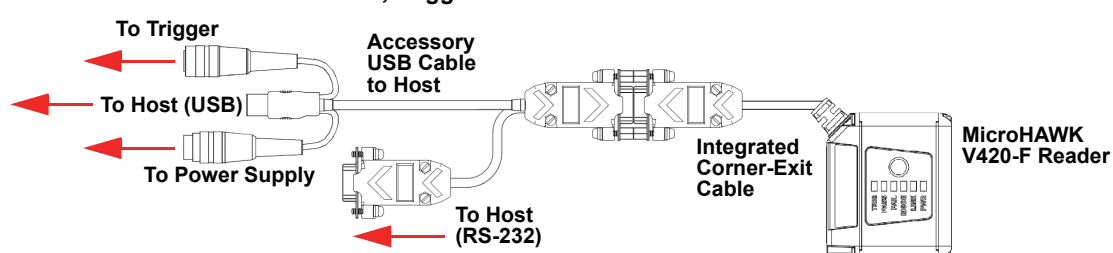

## MicroHAWK V420-F Configuration Options (Continued)

*V420-F with IB-131 and IC-332*

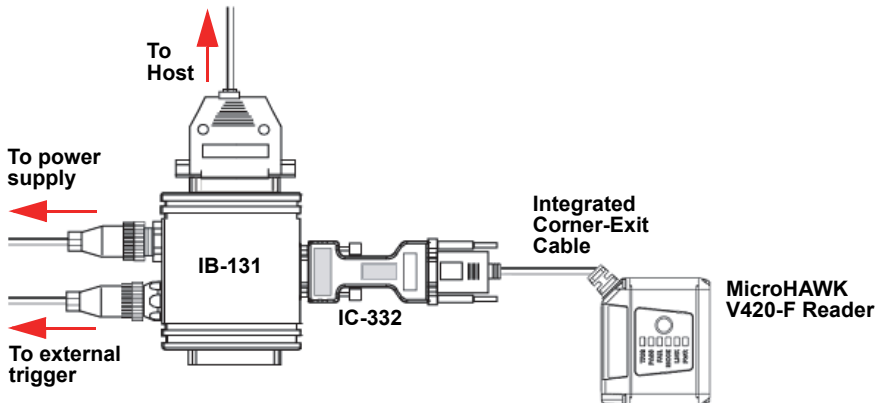

## MicroHAWK V430-F Configuration Options

- Mount the reader securely in its stand (not supplied).
- Mount the reader as required by the application.
- Connect the power cable to the MicroHAWK V430-F.
- Connect the Ethernet cable to the MicroHAWK V430-F.
- Connect the Ethernet cable to the host.
- Connect the power cable into the power source.

*Basic V430-F Configuration*

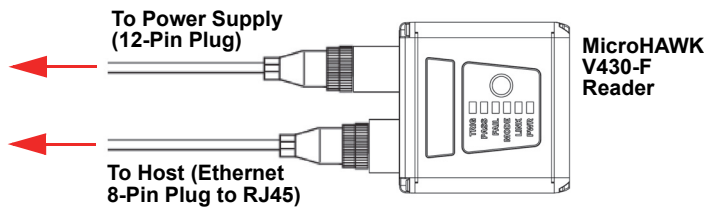

*V430-F M12 12-Pin Socket to 9-Pin Socket and M12 Plug*

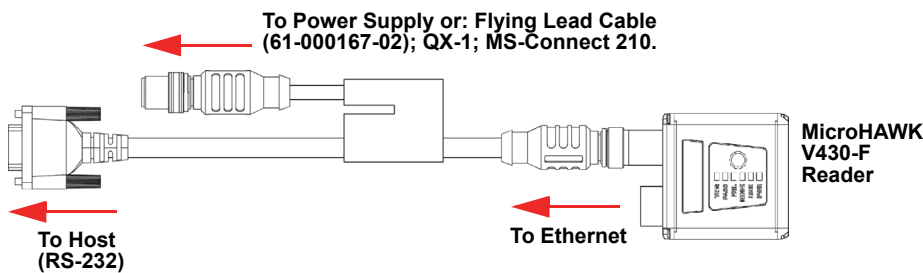

*V430-F Configuration with QX-1 Interface Device*

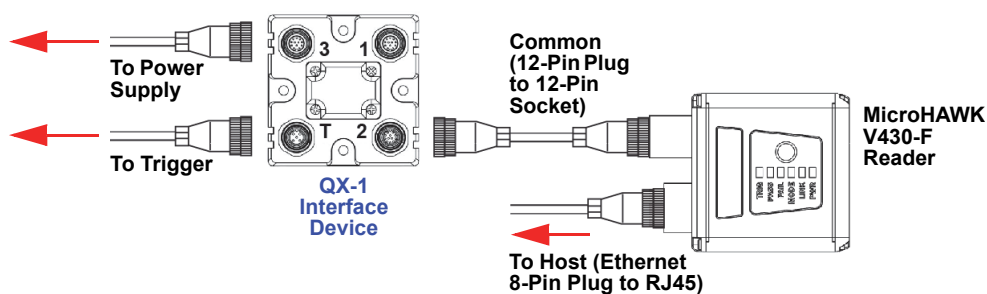

**Important:** See [Appendix B](#) for V320-F, V330-F, V420-F, and V430-F pin assignments.

### QX-1 Interface Device

The QX-1 Interface Device (98-000103-02) simplifies the installation of MicroHAWK readers. It is used to break out and distribute Power, Communications, and Digital I/O using standard MicroHAWK cables and accessories.

#### Connectors

- (1.) **Connector 3** – Power is supplied through Connector 3. Power is distributed to all other QX-1 Connectors to provide power to the reader, Photo Sensor (Trigger), and Smart Light.
- (2.) **Connector 1** – Smart Lights or a Host Serial Cable are connected to Connector 1. In the case of a Smart Light, Power and/or Power and Strobe Control are distributed to the Smart Light. In the case of the Host Serial Cable, RS-232 and Digital I/O are distributed to the DB-9 connector that can be connected to a Host.
- (3.) **Connector T** – A Photo Sensor is typically connected to Connector T. The Trigger signal is sent directly to the reader.
- (4.) **Connector 2** – The readers are connected to Connector 2. Power, Trigger, RS-232, and all Digital I/O including the Strobe Signal are routed through this cable.

#### Switches

There are two switches that control how signals are routed through the QX-1 Interface Device. For the MicroHAWK, the two switches are set to the right by default, to distribute power to all connectors, and to send the Trigger signal to the reader.

#### QX-1 Connector View and Switch Settings

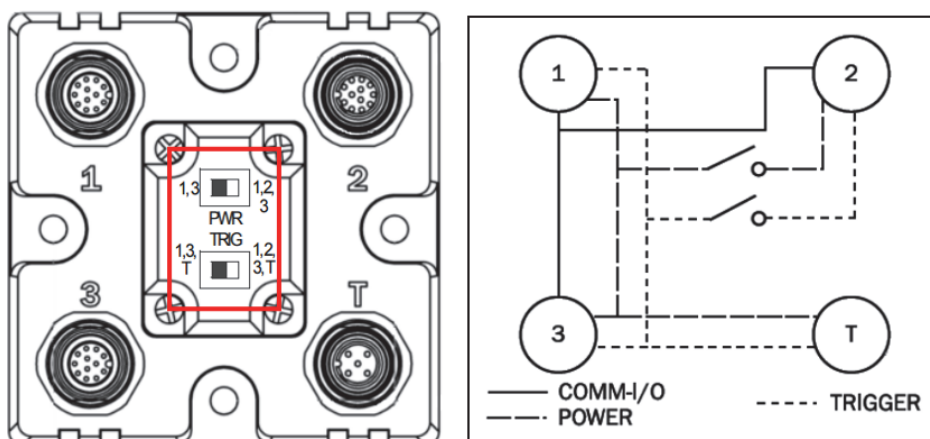

The QX-1's switches are set to the right by default for MicroHAWK use. In this configuration, communication, power, and trigger are distributed to all connectors.

#### Examples of Common MicroHAWK Configurations using the QX-1 Interface Device

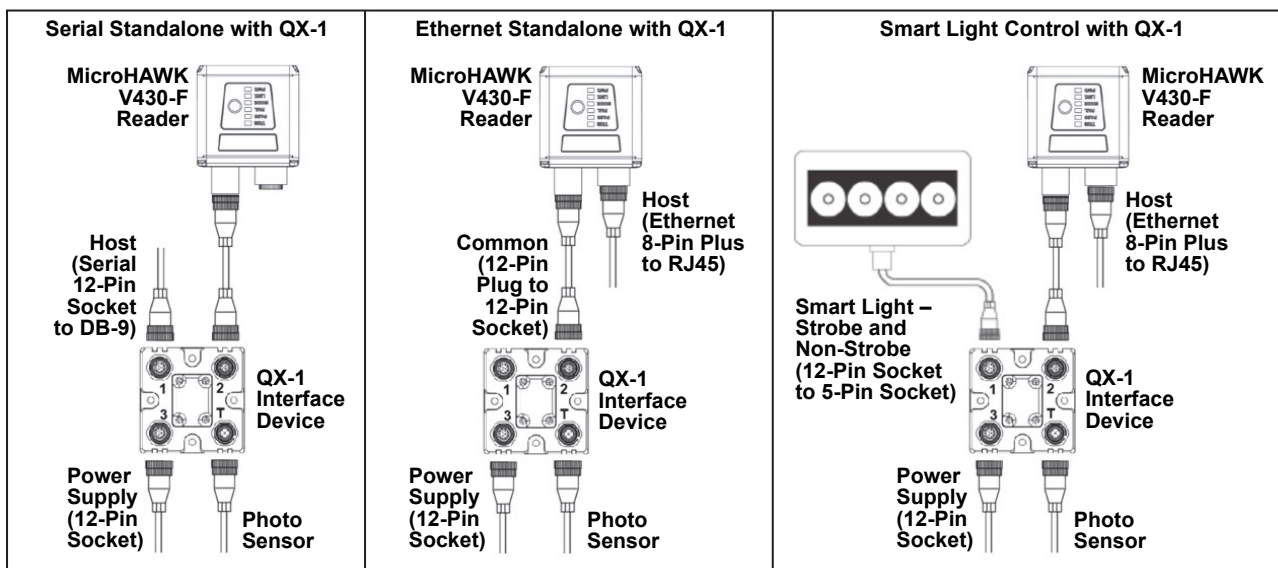

## 2-1-2 Check MicroHAWK Status LEDs

### MicroHAWK V420-F and V430-F LED Indicators

The top of the MicroHAWK V420-F and V430-F Readers have multiple LEDs that indicate different inspection, trigger, camera, communication, and power states.

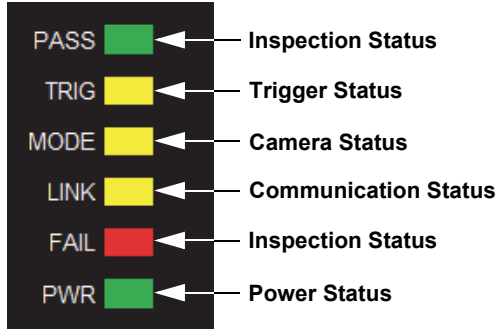

#### Additional Feedback from V420-F and V430-F LEDs

**Green Flash** – A green flash from the front of the unit indicates a Good Read.

**Blue Targeting Pattern** – The blue targeting pattern from the front of the unit allows the user to center an object in the reader's field of view.

LED	Status	Description
PASS	On	Active State (PASS)
	Off	Inactive State
TRIG	On Steady	Continuous Trigger
	Off	Waiting for Trigger Event
	Flashing On/Off	Trigger Event
MODE	On Steady	Unit Ready
	Off	Unit Not Ready
LINK	On Steady	Link Established
	Off	No Link/Activity
	Flashing On/Off	Link Established and Activity on Link
FAIL	On	Active State (FAIL)
	Off	Inactive State
PWR	On	Power On
	Off	No Power Applied to Unit

### MicroHAWK V320-F and V330-F LED Power Status Indicators

The top of the MicroHAWK V320-F and V330-F Readers have a single LED that indicates whether or not the power is on.



#### Additional Feedback from V320-F and V330-F LEDs

**Green Flash** – A green flash from the front of the unit indicates a Good Read.

**Blue Targeting Pattern** – The blue targeting pattern from the front of the unit allows the user to center an object in the reader's field of view.

LED	Status	Description
POWER	On	Power On
	Off	No Power Applied to Unit

### MicroHAWK V330-F LINK and Activity LED Indicators

The back of the MicroHAWK V330-F Reader has two LEDs that indicate LINK and Activity status.

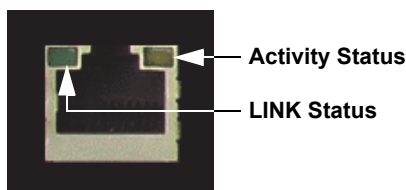

LED	Status	Description
LINK	Green On Steady	Operating as a 100 Mbps Connection
	Off	No Link Established
Activity	Amber Blinking	Activity on the Port
	Off	No Activity on the Port

### 2-1-3 Mount and Position the Reader

- Position the reader several inches from the symbol. You may need to reposition the reader a few times to find the ideal distance.
- Tip the reader relative to the symbol to avoid the glare of direct (specular) reflection.
- Symbols can be rotated (tilted) at any angle; however, for best results symbols should be aligned with the field of view. In the case of linear symbols, aligning the bars in the direction of their movement (ladder orientation) will minimize the chances of blurring and will result in more consistent decodes.

**Important:** Avoid excessive skew or pitch. Maximum skew is  $\pm 30^\circ$ ; maximum pitch is  $\pm 30^\circ$ . The illustration below shows approximate skew axis, pitch axis, and tilt axis.

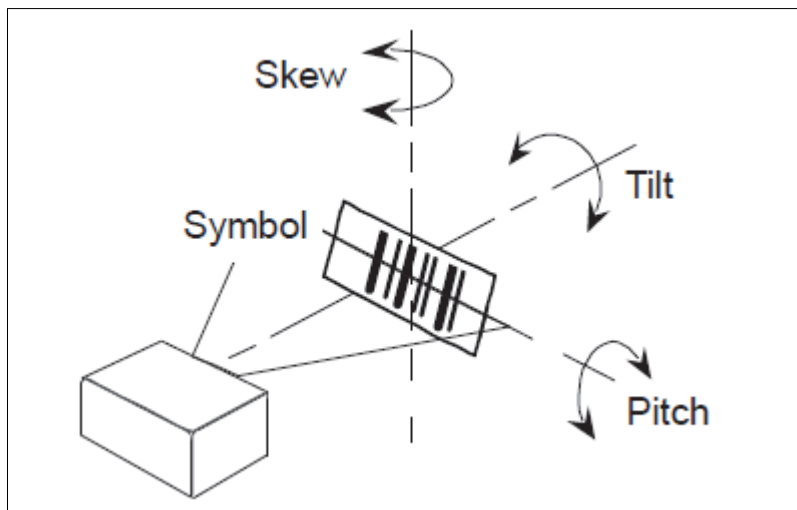

**Reader and Symbol Orientation**

## 2-1-4 Install WebLink Drivers (V320-F and V420-F)

If you have loaded the **DDU (Device Discovery Utility)** onto your computer, the necessary **MicroHAWK USB drivers** will already have been installed. You can plug the reader into the PC and the drivers will load automatically.

If you have not loaded the DDU onto your computer, the reader will be factory-configured to **USB Drive Mode**. When you first plug in the reader, it will act as a USB key. The drivers can be installed directly from the reader using the following steps.

- 1** Plug the reader into a USB port and wait for the **AutoPlay** dialog to appear.
- 2** Click the **Open** folder to view files and double-click the **Double-Click Here.bat** batch file.
- 3** At the command prompt, select **option 1** and then type **Enter**. The **VCOM** and **USBLAN** drivers will be installed.

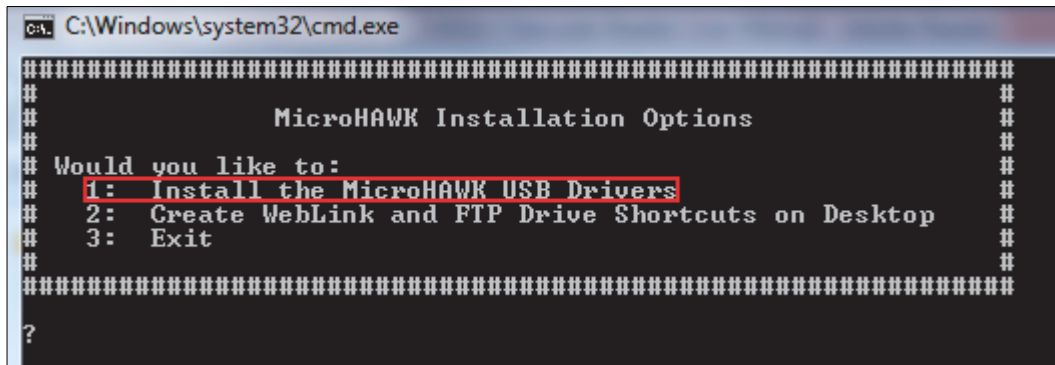

```

C:\Windows\system32\cmd.exe
#####
#
#           MicroHAWK Installation Options
#
# Would you like to:
# 1: Install the MicroHAWK USB Drivers
# 2: Create WebLink and FTP Drive Shortcuts on Desktop
# 3: Exit
#
#####
?
  
```

- 4** At the command prompt, select **option 2** to install the **WebLink** and **FTP drive** shortcuts. WebLink and MicroHAWK FTP drive shortcut icons will appear on the desktop.

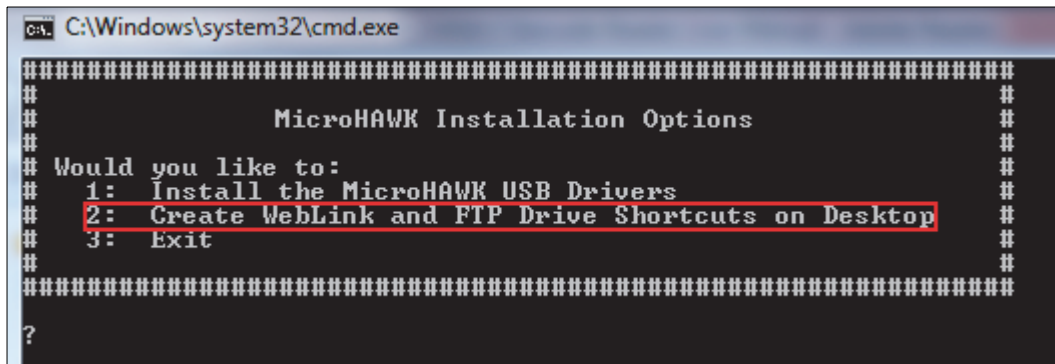

```

C:\Windows\system32\cmd.exe
#####
#
#           MicroHAWK Installation Options
#
# Would you like to:
# 1: Install the MicroHAWK USB Drivers
# 2: Create WebLink and FTP Drive Shortcuts on Desktop
# 3: Exit
#
#####
?
  
```

- 5** When the drivers and shortcuts have been installed, unplug the reader from the USB port.
- 6** Re-plug the reader into the USB port and wait for the reader to reboot and enter read mode (LEDs ON).
- 7** Start WebLink. The default address for the reader is **192.168.188.2**. If multiple readers are installed, they will be incremented automatically. The second reader will be **192.168.188.10**.
- 8** Double-click the **FTP drive** shortcut and log in with username: **target** and password: **password**.
- 9** The FTP drive is opened so you can access additional resources and installers in the **Tools and Documentation** folder.

You are now ready to use the **MicroHAWK V320-F** or **MicroHAWK V420-F** with **WebLink**.

If the reader will be used on another computer without the drivers installed, it can be placed back into **USB Drive Mode** from WebLink so the process described above can be repeated. See [Enable USB Drive Mode](#) for details.



## 2-1-5 Connect to WebLink

### WebLink System Requirements

#### ● Operating System Requirements

- Microsoft Windows 10 (64-Bit) or Microsoft Windows 7 (64-Bit)

**Note:** Using an Embedded OS (Windows CE) and / or an underpowered machine (limited RAM or limited disk space) is not recommended.

#### ● Hardware and Performance Requirements

- Intel Core i3 Duo Processor
- 2 GB RAM / 128 MB Video RAM
- 1 GB Hard Drive Space
- 32-Bit Color Display
- 4.0 Windows Experience Index

#### ● Browser Requirements

- Google Chrome (Recommended)
- Firefox
- Microsoft Edge
- Opera
- Safari (Mac-Only)

#### ● Browser Feature Requirements

WebLink requires certain features to be supported by the hosting browser. Support for these features are checked before WebLink loads, and if they are not available, an error message is displayed.

The following features are required by WebLink and are checked at startup:

- Web Sockets
- HTML5 Canvas
- HTML5 Audio

### Static Connection

- Navigate to **Control Panel > Network and Sharing Center** on your PC.
- Click **Local Area Connection 4**. In the **Status** dialog, click **Properties**.
- In the **Local Area Connection Properties** dialog, select **Internet Protocol Version 4 (TCP/IPv4)** and click **Properties** again. Set your PC to a **192.168.188.X** IP address (**192.168.188.5**, for example).
- Click **OK**.
- Open a web browser and type the reader's default IP address (**http://192.168.188.2**) in the web browser's address bar.

The reader will connect to WebLink.

### DHCP Network Connection

- Plug your reader into the your network adapter.
- Connect to the reader via **Ethernet TCP/IP**.
- Click **Search** to find the reader. When the reader appears in the field below the **Search** and **Send** buttons, select it.
- Change the reader from Static to **DHCP** and click **Send and Save**. The reader will reboot.
- When the reader is found, note the new IP address that is generated.
- Open a browser and type the new IP address.

WebLink will load.

## Use the Device Discovery Utility (DDU) to Connect to WebLink

You can also connect to WebLink with Omron Microscan's **Device Discovery Utility**, available at <https://automation.omron.com>.

Once you have downloaded the Device Discovery Utility .exe file from Omron Microscan's website and installed the utility, select Device Discovery Utility from your Start Menu.

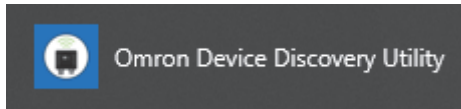

The following screen will appear.

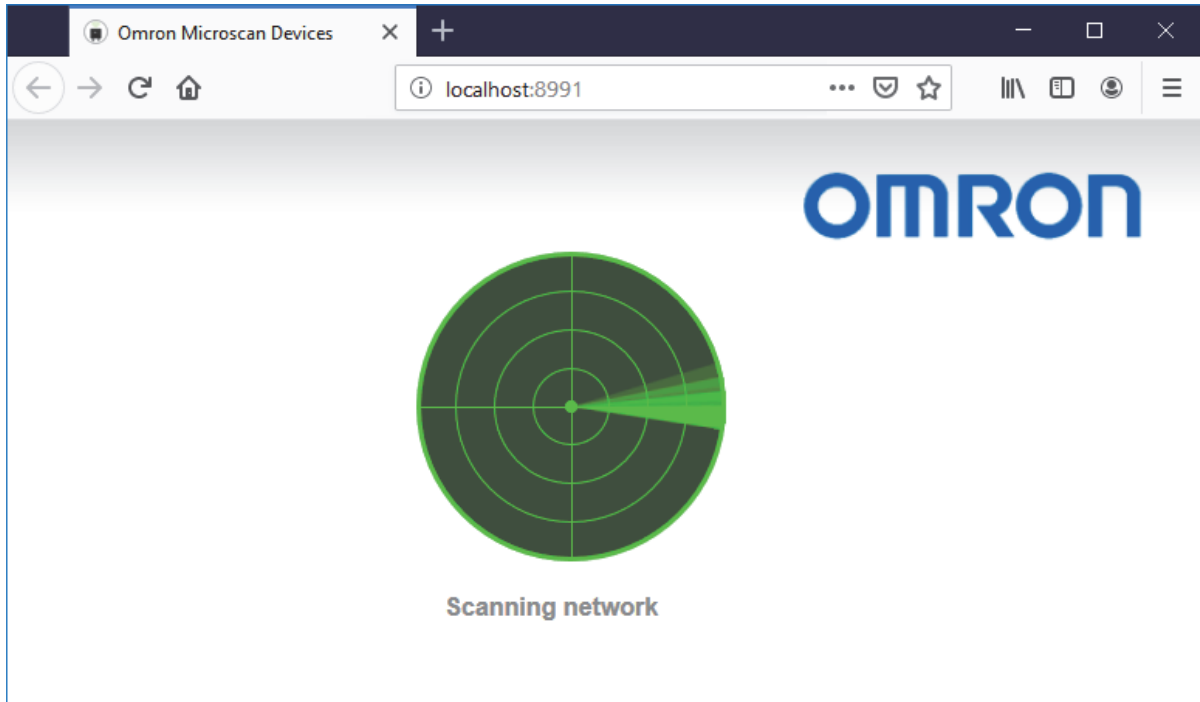

When your reader is located on the network, its identifying information will be shown as in the example below.

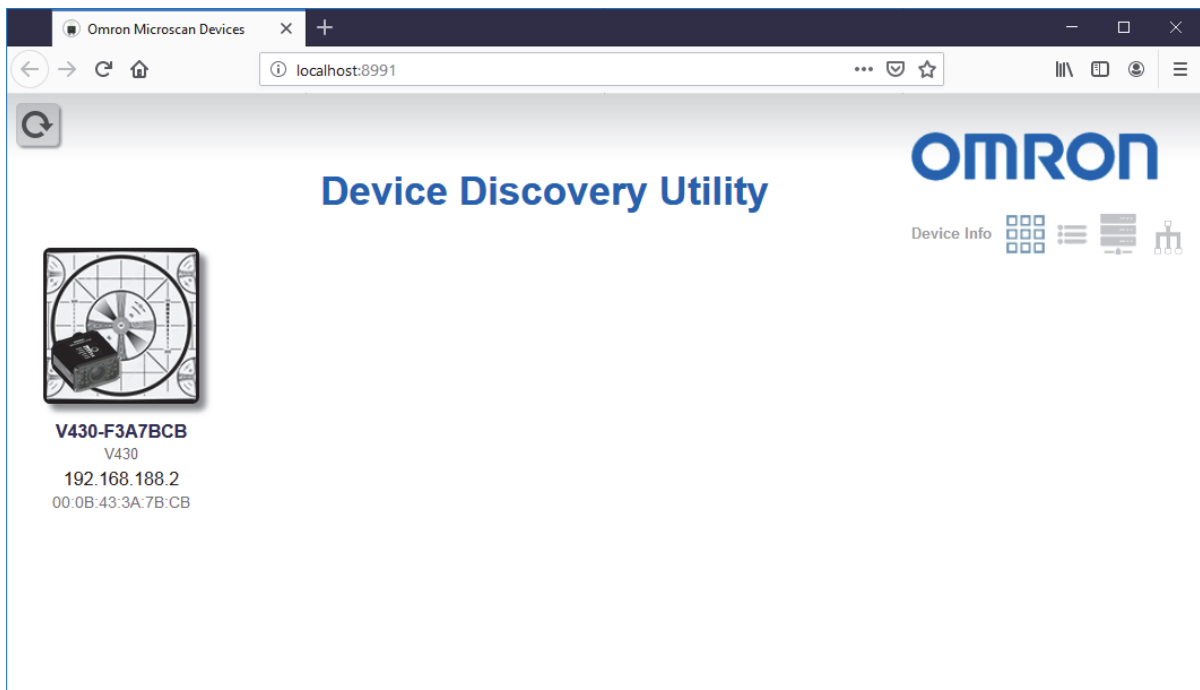

Click on your reader to bring up the information and settings view.

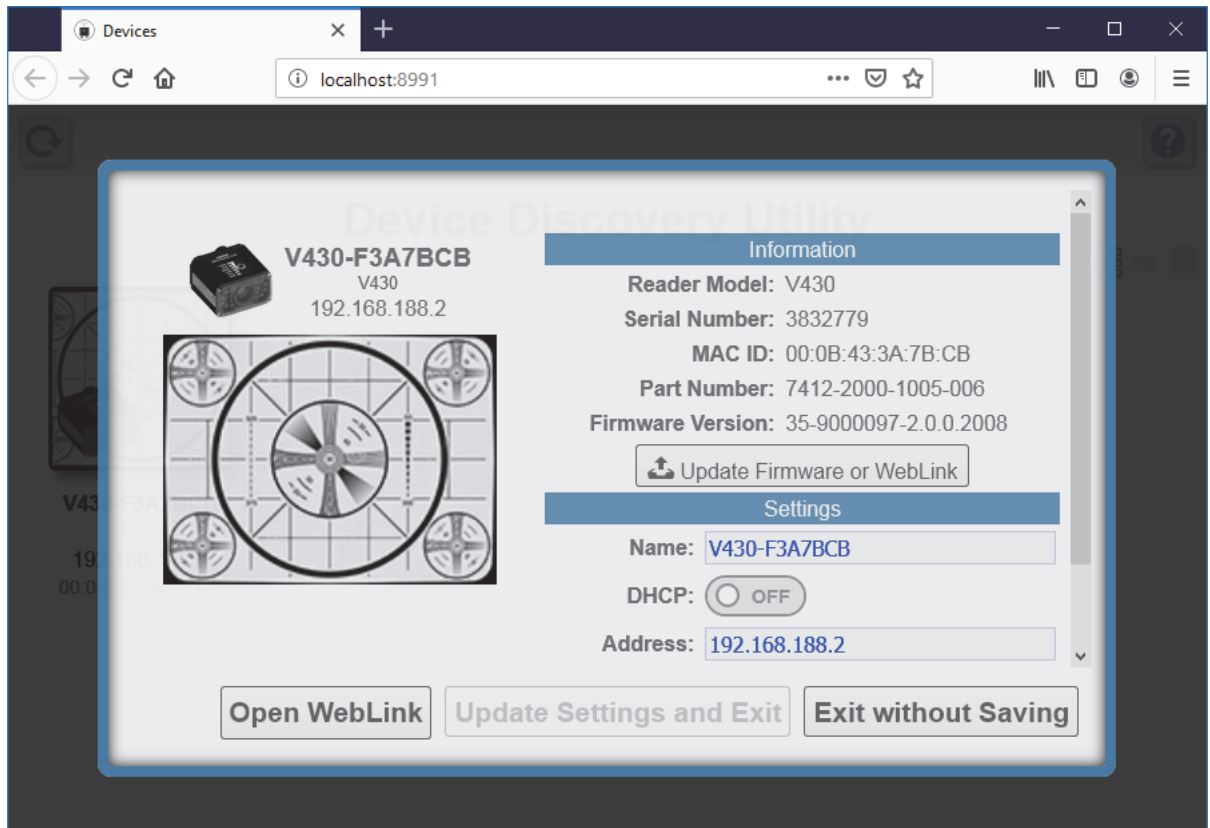

2

Click **Open WebLink**. The WebLink splash screen will appear as the program opens.

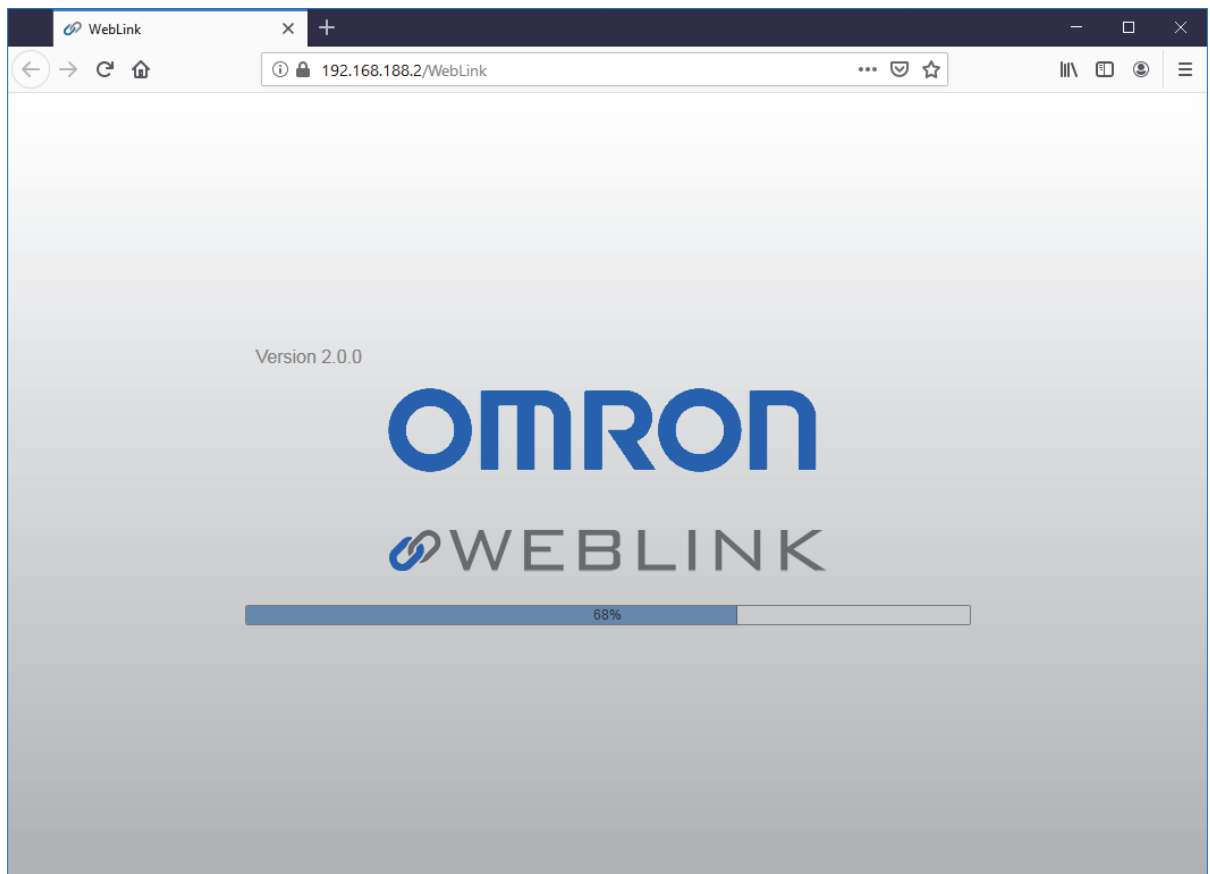

## 2-1-6 Configure Daisy Chain (If Required by Application)

**Daisy Chain** is useful in applications where:

- More than one symbol type is present;
- A symbol may be present on multiple sides of a package;
- Symbols are presented at different depths;
- Multiple readers are required to cover a large field of view;
- There is a need to find a symbol on a circular object in any orientation.

A Daisy Chain consists of one **parent** and one or more **child** devices. The child devices report their data to the parent, which then reports the data to the network, effectively allowing all readers to act as one. In other words, the outside world interacts with one unit – the parent reader.

The **Device Discovery Utility (DDU)** is used to configure the Daisy Chain group where the parent reader and the child readers are defined. The parent reader interacts with a host computer or PLC. A parent reader that receives a trigger will send a trigger to each of the child readers. Any symbol decoded by the child readers will be communicated to the parent, which collects all of the decodes from the children and will communicate them to the host. The Daisy Chain uses one UDP packet for the decoded data from all readers. Combined data from all readers larger than 3800 bytes will not be reported.

### Overview of Setup Process

Use the Device Discovery Utility to define the Daisy Chain group, the parent reader, and the child readers.

Use WebLink to configure each of the readers in the Daisy Chain group as desired for the application.

#### ● Tips

**The parent reader should:**

- Configure for application requirements: Match String, Format Output, Trigger, (Digital) Outputs, etc.

**The child readers should:**

- Use a Triggered cycle, such as External Edge.
- Use a timeout that occurs before the end of read cycle on the parent reader.

**Parent and child readers should:**

- Save settings to the flash memory of the readers.

## Setting Up a Daisy Chain Configuration with the Device Discovery Utility (DDU)

If your application requires readers to be deployed in a Daisy Chain configuration, the DDU can help you create such a configuration.

A Daisy Chain is a grouping of **2 to 8** readers that function as one. The DDU interface allows you to manage Daisy Chains, including their creation, monitoring, and deletion.

Connect 2 to 8 **V430-F** readers that have Daisy Chain-compatible firmware. From the DDU home page, click on the group icon located near the top-right.

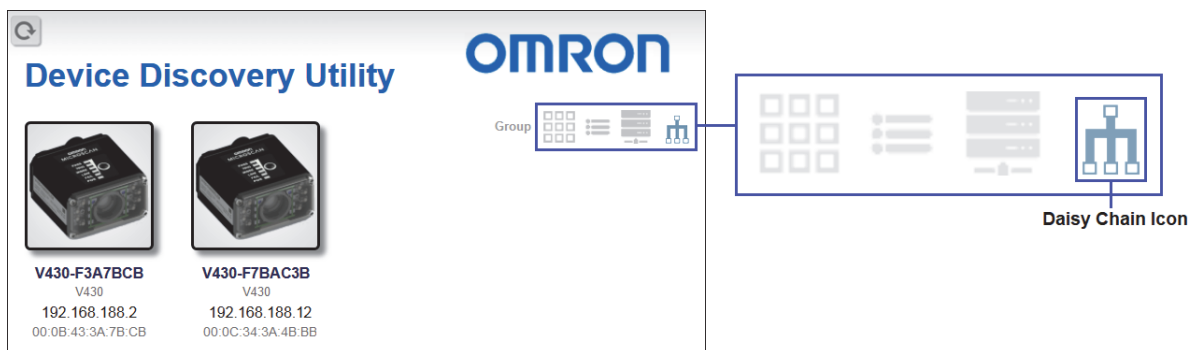

On the **Groups** page, assign a **Group Name** and click **Create**. This opens the interface that allows you to create a new Daisy Chain.

**Important:** Only Daisy Chain-enabled readers will appear in this view.

The screenshot shows the Daisy Chain creation interface. It has a 'Group Information' section with a text box for 'Group Name' and labels for 'Count: 0', 'Parent: 0', and 'Children: 0'. Below this is an 'All Devices' section with a 'Filter Devices' input field and a list of three devices: BBBB (192.168.188.75), RRRR (192.168.188.15), and QQQQQQ (192.168.188.70). There are also sections for 'Parent' and 'Children' which are currently empty. At the bottom, there are 'Create', 'Clear', and 'Exit' buttons. A red error message at the bottom states: 'A group name must be assigned Group must consist of at least one parent and one child'.

The five most important areas in the Daisy Chain creation interface are:

- **Group Information:** Contains the **Group Name**, Total **Count**, **Parent** Count, and **Children** Count of the Daisy Chain being created. This information is dynamically updated as you make changes. The Group Name text box is editable, and a group name must be provided to create a new Daisy Chain.

This is a close-up of the 'Group Information' section. It features a blue header with the text 'Group Information'. Below the header, there is a text box for 'Group Name' with a red border, followed by 'Count: 0', 'Parent: 0', and 'Children: 0'.

- **All Devices:** Contains all Daisy Chain-enabled devices that appear on the network. Devices are represented by an image, a model, and an IP address. Each device is clickable. You can search for specific devices using the **Filter Devices** search box.

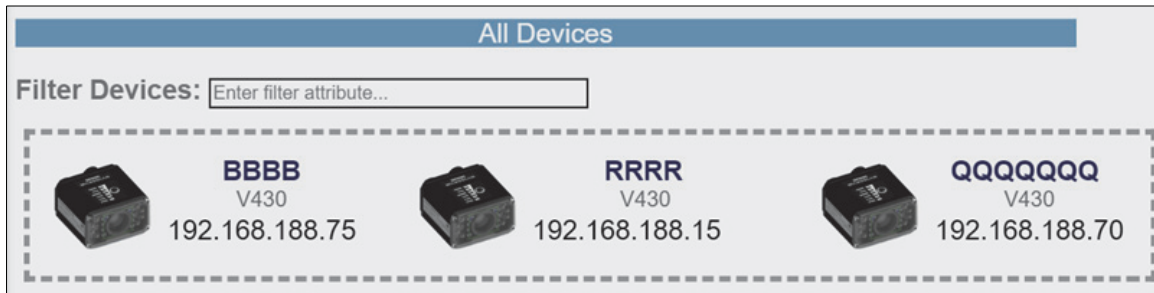

- **Parent:** The **Parent** container is empty upon opening the interface. This container is used to store the **Parent** reader in the Daisy Chain. A maximum of one device can be placed in the Parent container. A minimum of one device must be placed here to create the Daisy Chain.
- **Children:** The **Children** container is empty upon opening the interface. This container is used to store the Children readers in the Daisy Chain. A minimum of one device must be placed here to create a Daisy Chain, and a maximum of seven devices may be placed here.

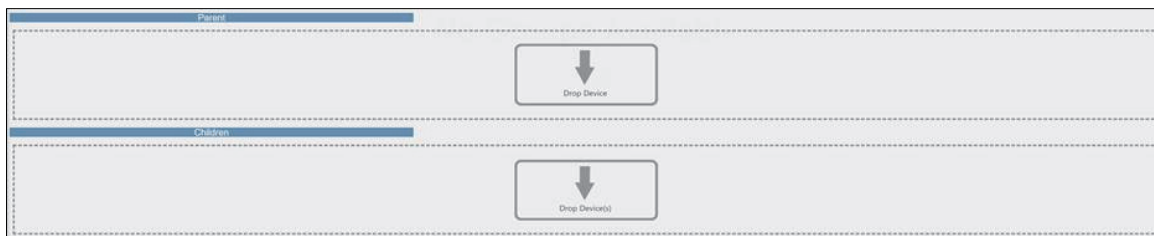

- **Buttons:** This section of the interface includes the **Create**, **Clear**, and **Exit** buttons.
  - **Create** creates a new Daisy Chain if all the necessary conditions are met.
    - Note:** The **Create** function does not delete a Daisy Chain and only resets the interface.
  - **Clear** resets the interface to its original state.
  - **Exit** closes the window.

Below these buttons, messages will appear that indicate any errors in the potential Daisy Chain being created. These errors appear and disappear based on dynamic validation of user input.

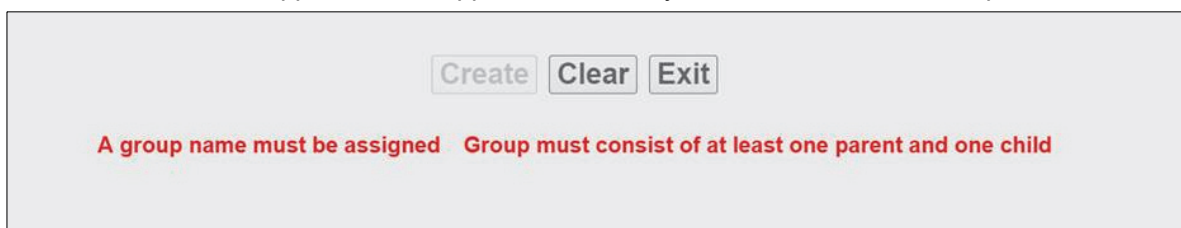

The Daisy Chain creation interface is drag-and-drop, meaning you can move devices around the page to build your Daisy Chain.

The **All Devices**, **Parent**, and **Children** containers are drop zones for readers. To move a device, place the cursor over a device, left-click, and hold down. Then drag the device in another drop zone by moving the cursor / reader over it and releasing your mouse's left-click button. Valid reader drop zone areas are designated by the dotted grey line surrounding them.

Drag and drop a reader into the **Parent** drop zone. Drag and drop one or more other Daisy-Chain-enabled readers into the **Children** drop zone. Assign a name to the group.

If errors occur (**A group name must be assigned or Group must consist of at least one parent and one child**), resolve them as needed, and then you will see that the Create button will be active. A valid Daisy Chain configuration should resemble the example below.

Group Information

Group Name:

Count: 3  
Parent: 1  
Children: 2

All Devices

Filter Devices:

<b>BBBB</b> V430 192.168.188.75	<b>RRRR</b> V430 192.168.188.15	<b>QQQQQQ</b> V430 192.168.188.70
---------------------------------------	---------------------------------------	---

Parent

<b>QQQQQQ</b> V430 192.168.188.70
---

Children

<b>BBBB</b> V430 192.168.188.75	<b>RRRR</b> V430 192.168.188.15
---------------------------------------	---------------------------------------

2

If the Daisy Chain was created successfully, the popup will close, and the newly established Daisy Chain will be displayed as a diagram or map. This diagram is generated based on the number of devices in the Daisy Chain. Whichever number of devices in the Daisy Chain, the Parent always appears above and all Children devices below.

**Sample Daisy Chain with One Parent and Two Children**

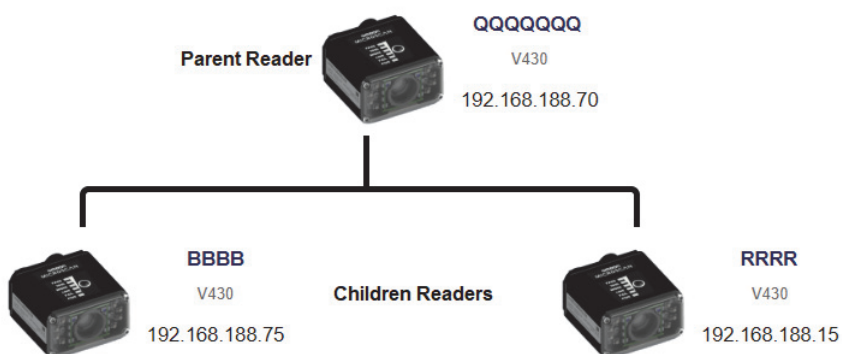

**Sample Daisy Chain with One Parent and One Child**



There is no limit on the number of Daisy Chains that can be created. All current, active Daisy Chains will appear on the Daisy Chain page in the DDU. Click on any Daisy Chain to open its information popup. This popup contains information about the Daisy Chain configuration, including Group Information, Parent reader identity, and Children reader identities. The Daisy Chain information popup also contains a Delete button, which deletes the entire Daisy Chain configuration – Parent and Children.



## Daisy Chain Fundamentals

**Parent:** The master device in the group. Responsible for establishing the group on the firmware side and reporting the Daisy Chain to the DDU. There can be only one Parent in a Daisy Chain. The parent is responsible for receiving **create** and **delete** commands from the DDU.

**Children:** Any reader that is currently a part of a Daisy Chain that is not the Parent device is a Child device. Child readers report data to the Parent reader.

### A Valid Daisy Chain:

- Must have at least two readers;
- Must consist of V430-F readers;
- Must contain one Parent reader;
- Must contain one or more Child readers (up to 8);
- Must have a group name less than 25 characters in length;
- Must have a valid group name [ **a-z, A-Z, 0-9, \_, -** ]



The creation and deletion of Daisy Chains occurs via UDP messages that are sent from the DDU user interface to the readers. If a parent device recognizes that it has been configured in a Daisy Chain, it creates the firmware connection, and then broadcasts UDP messages that contain all the information needed by the user interface to produce a functional Daisy Chain configuration. The user interface will only create a new Daisy Chain if it receives a broadcast from the Parent device with the Daisy Chain information. The core communication between the user interface and the device(s) is via the Parent device. The firmware is responsible for connecting the Parent device to the Children devices and then reporting the status.

A Daisy Chain consists of one Parent and one or more Children devices. The Children devices report their data to the Parent, which then reports the data to the network, effectively allowing all readers to act as one.

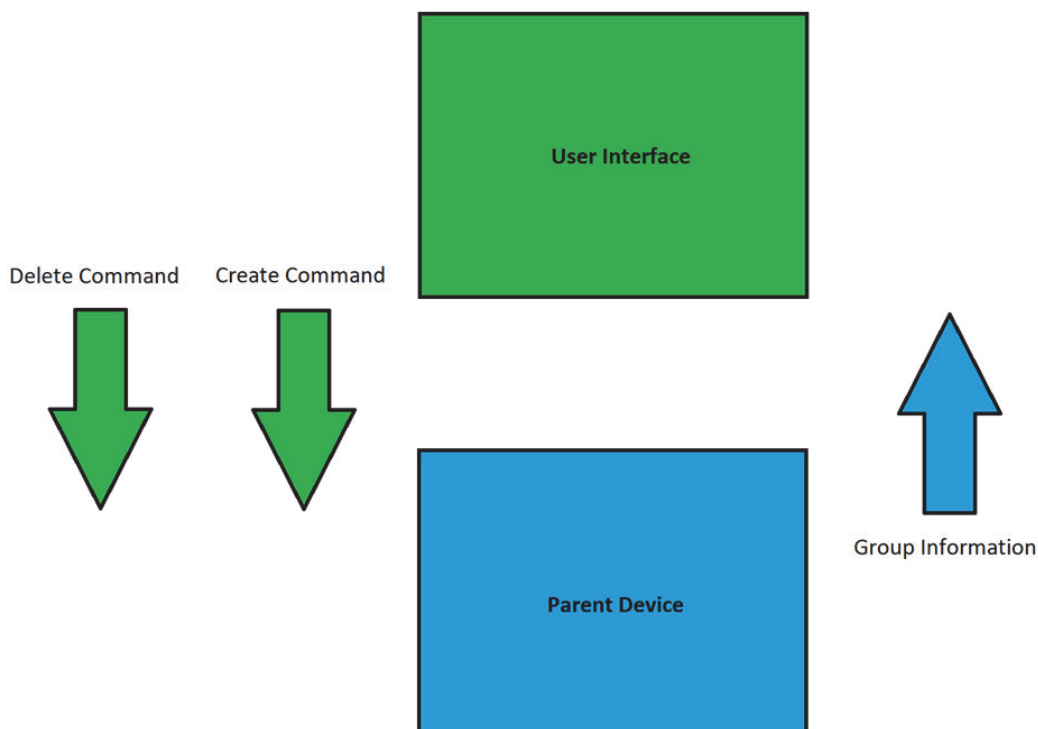

## Error Handling

If the **Parent** reader in a Daisy Chain is turned off for more than one minute, a **Disconnected** notice will appear in the dialog. This notice will disappear once the Parent reader is turned back on.



If a **Child** reader in a Daisy Chain is turned off, even temporarily, an **Offline** notice will appear below the respective Child on the reader map. Once turned back on, the Offline notice will disappear.

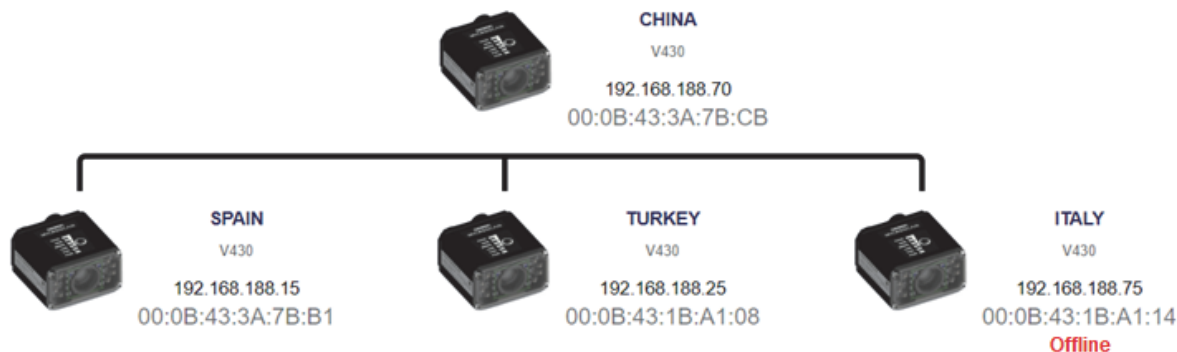

Some errors can occur when you have already established a Daisy Chain and confirmed that it's working.

In this hypothetical error scenario, the Parent reader = **P**, the first Child reader = **C1**, the second Child reader = **C2**, and the third Child reader = **C3**.

The user shuts down the application and completely turns off power on **P**, **C1**, **C2**, and **C3**. The user comes in the following day and turns on all the devices except **C3** and then starts the application.

The complete Daisy Chain can't be re-initiated because it is missing a unit. To account for this, the application will place a "dummy device" in place of the missing **C3**. The dummy device will display an error icon, the missing device's MAC address, and an **Offline** status message. It will continue show this status if the browser is restarted. This offline device can't be clicked in the Daisy Chain info page. It is only there to alert the user of the missing device.



If the user turns on **C3** when seeing the status shown in the diagram above, the application will automatically resolve the issue and a new, fully-formed Daisy Chain with **C3** as a full device will be created. There is no need to restart the browser or Parent device.

## 2-1-7 Explore the Start View

The **Start** view is the initial view you will see when the WebLink session begins. The connected reader is shown, along with its **user-defined name**, **IP address**, **License Options**, **Reader Model**, **Serial Number**, **MAC ID**, **Firmware version**, **WebLink version**, **Sensor**, **Optics**, **Decoder**, and **Speed**.

**Note:** The **user-defined name** must be **19** characters or fewer.

This view allows you to choose **Assisted Setup**, to **Create a New Setup**, or to **Load a Setup**.

The screenshot displays the OMRON WebLink Start View. The interface is divided into several sections:

- Top Bar:** Contains 'Start', 'Setup', and 'Run' buttons, along with the OMRON logo and system icons.
- Left Sidebar:**
  - Reader Information:** V430-F1BA108, 192.168.168.2
  - Reader Model:** V430-F
  - Serial Number:** 1010996
  - MAC ID:** 90:98:43:1B:A1:08
  - Firmware:** 35-900097-2.0.0 RC 20
  - WebLink:** 2.0.0 RC 8
  - Sensor:** ES0400 (SXGA)
  - Optics:** S0
- Setup Options:** Assisted Setup..., Create a New Setup, Load a Setup...
- Central View:** A camera feed showing a QR code being scanned. The QR code contains the text 'OMRON123' and 'DataMatrix type = 1.2.3'. A status bar at the bottom of the camera view indicates 'Image 1 of 2 from cycle 100'.
- Right Panel:**
  - Counts:** Cycles: 100, Reads: N/A, No Read: N/A, Mismatch: N/A, Read %: N/A.
  - Rate:** Capture: 50.0 ms (17.2%), Decode: 50.0 ms (17.2%), Overhead: 6.2 ms (0), Total Read: 106.2 ms (30.0%), Trip Rate: 25.6 ms (13.22%).
  - Read Time (ms):** A line graph showing read times.
  - Output Data:** A list of read data entries, each showing 'OMRON123' and 'DataMatrix type = 1.2.3'.

2

## 2-1-8 Create a New Setup or Load an Existing Setup

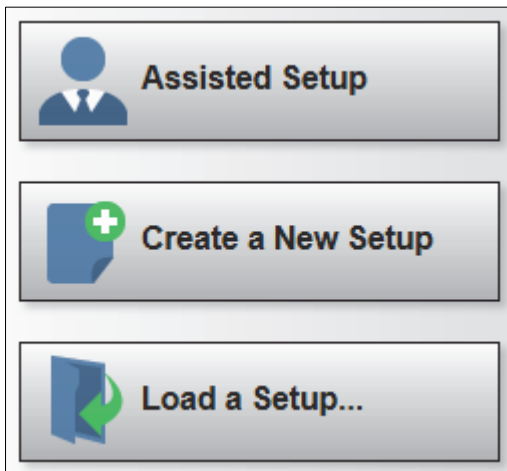

### Assisted Setup

When you click the **Assisted Setup** button in the **Start** view, a dialog will appear asking you a series of application-based questions. Based on your answers, WebLink generates your initial setup automatically. Once the setup is created, you can fine-tune its parameters in the **Setup** view.

 A screenshot of the 'Assisted Setup' dialog box. The title bar says 'Assisted Setup'. The main content area asks 'What code types will you be reading?' and shows a selection of code types: Data Matrix, QR code, Code 128, Code 39, Code 93, 12of5, UPC, PDF417, Micro PDF, DataBar-14, DataBar Limited, DataBar Extended, and Micro QR Code. Below this, it asks 'How many codes do you need to read at once?' with a text input field containing '1'. Then it asks 'Select the type of application.' with four icons: a hand, a circular arrow, a sine wave, and a square wave. Next, it asks 'Would you like to rename your reader?' with a 'Yes' radio button. At the bottom, there are two text input fields for 'Reader Name' containing '18BFA8' and '00:0B:43:18:BF:A8'. At the very bottom are 'CANCEL' and 'CREATE SETUP' buttons.

### Create a New Setup

The **Start** view also allows you to **Create a New Setup** without using **Assisted Setup**. When you click the **Create a New Setup** button, WebLink searches for any differences from default in the reader parameters. If no differences from default are found, you will see the **Setup** view. If differences from default are found, an alert will appear asking if you want to restore default settings.

### Load a Setup

Select **Load a Setup** to load an existing **.json** WebLink setup file.

## 2-1-9 Explore the Setup View

The **Setup** view allows you to configure all aspects of a setup. Multiple discrete sections of the interface give you the ability to set **Cycle**, **Acquire**, **Decode**, **Match String**, **Format Output**, **Output parameters**, and **Favorites**.

Clicking the **Save** icon at the upper right saves current settings to the reader's flash memory so the settings will be available when the reader is rebooted.

The **question mark icon** at the upper right opens **WebLink Help**.

The **gear icon** at the upper right brings up the **Application Settings** menu.

**Note:** The **1, 2, and 3 output indicators** at the lower right of the screen display the results of the last read cycle.

The screenshot displays the OMRON MicroHAWK Setup View. The interface is divided into several sections:

- Top Bar:** Includes 'Start', 'Setup', and 'Run' buttons, the OMRON logo, and icons for help, save, and settings.
- Left Panel (Read Cycle Sequence):**
  - Cycle:** Set to 'Continuous' with a checkmark. Timeout after 500 ms, Look for 1 symbols.
  - Acquire:** Set to 1299  $\mu$ s, 0% enhancement. Distance: 4.5 Inches. Enhance: Disabled.
  - Decode:** Includes checkboxes for Data Matrix, QR code, Code 128, Code 39, Code 93, I2of5, UPC, PDF-417, Micro PDF, DataBar-14, DataBar Limited, DataBar Extended, and Micro QR Code.
  - Match String:** Off.
  - Format Output:** Off. Includes options for Preamble <CR> and Postamble <CR><LF>.
  - Outputs:** 1: Mismatch or No Read, 2: Mismatch or No Read, 3: Mismatch or No Read.
  - Favorites:** Section at the bottom.
- Center View:** Shows a camera feed of a QR code with a green bounding box. Text 'http://www.microscan.com' is overlaid on the code. Below the code, 'USA 195.9236' is visible. A green checkmark is in the bottom right corner of the view.
- Right Panel (Performance Metrics):**
  - Counts:**

Cycles	1312
Reads	1312
No Read	0
Mismatch	0
Read %	100.00
  - Rate:**

Capture	29.3 ms	34.2/s
Decode	60.0 ms	16.7/s
Overhead	0.4 ms	0
Total Read	89.5 ms	11.2/s
Trig Rate	422.3 ms	2.37/s
  - Read Time (ms):** A line graph showing read time fluctuations.
  - Output Data:** A list of URLs: `http://www.microscan.com/...`
- Bottom Bar:** Displays the model number 'V430-F3A7BCB' and IP address '192.168.188.2 | 3832779' along with three numbered output indicators (1, 2, 3).

## 2-1-10 Configure Read Cycle Settings

The **Cycle** section of the **Setup** view allows you to modify the trigger, determine the number of symbols for the reader to expect, and set **Read Cycle Timeout**. A dropdown menu of various Cycle types provides a variety of options, each with configurable parameters.

### Presentation

This mode uses **Continuous Read Auto** along with **Continuous Capture Mode** and a **Timeout at End of Read Cycle**. **Green Flash Mode** is set to **Static Presentation** and the **Green Flash Duration** is set to **250 ms**.

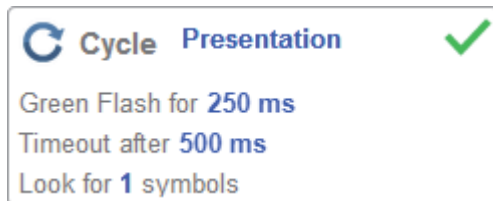

### Continuous

This mode allows you to set the **Read Cycle Timeout** and the expected **Number of Symbols** from 1 to 100.

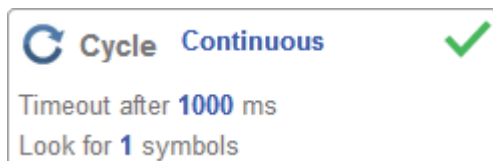

### Triggered

This mode sets the read cycle to **Serial Data and Edge**, **End of Read Cycle** is set to **Timeout or New Trigger**, and **Capture Mode** is set to **Rapid Capture** with 1 capture. You can adjust the **Serial Trigger**, **Trigger Delay**, **Timeout**, and **Number of Symbols**.

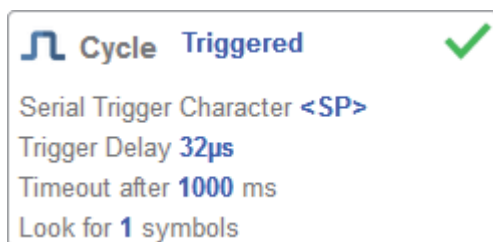

### Start / Stop

This mode uses **External Level** with a **Read Cycle Timeout** and **Continuous Capture**, allowing you to set **Leading Edge** and **Trailing Edge** as well as the **Serial Trigger** and the **Start** and **Stop** characters.

- **Serial Trigger (Non-Delimited) Off**

When **Serial Trigger** is set to **Off**, the start and stop characters are set to **NULL**, meaning that the trigger is disabled.

### ● Serial Trigger (Non-Delimited) On

When **Serial Trigger** is set to **On**, the start and stop characters are set to **S** and **E**. When the trigger button is clicked, it will use the current start and stop non-delimited triggers.

**Cycle Start/Stop** ✓

Trigger Filter Duration  
Leading Edge 32 us  
Trailing Edge 32 us

Serial Trigger (Non-Delimited):  
 On  
Start Character S  
Stop Character E

Timeout after 1000 ms  
Look for 1 symbols

2

## Custom

This mode allows you a wider variety of read cycle scenarios, including **Continuous Read Auto**. Use this mode to select **Trigger** mode and to set **Serial Trigger Character** and **Trigger Delay**; to select **Capture** mode and to set **Number of Captures**, **Rapid Capture** mode, and **Delay between Images**; and to select the **End Cycle On** setting as well as **Timeout** and **Number of Symbols**.

**Cycle Custom** ✓

Trigger: Serial Data and Edge  
Serial Trigger Character <SP>  
Trigger Delay 0  $\mu$ s

Capture Mode: Rapid Capture  
Num Captures: 1  
Rapid Capture Mode: Timed Capture  
Delay Between Images: 0  $\mu$ s

End cycle on  
Timeout or New Trigger  
Timeout after 500 ms

Look for 1 symbols



## 2-1-11 Configure Acquire Settings

**Acquire** settings allow you to set **Exposure** (signified by the sun icon) and **Gain** (signified by the dial and right-pointing arrow icon) in real time. Clicking any of these settings will cause a control to appear, allowing you to modify that setting. Settings take effect immediately.

- **Important:** There are 4 levels of Gain in SXGA readers. Each level corresponds to 25 percentage points, or one quarter turn of the Gain dial shown at left.
- Level 1 = 0 to 24%
- Level 2 = 25 to 49%
- Level 3 = 50 to 74%
- Level 4 = 75 to 100%

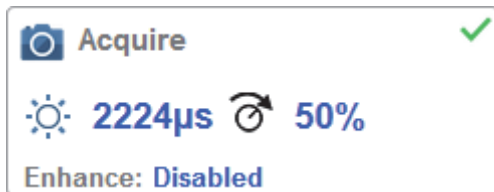

**Standard**

When **Auto Photometry** is enabled instead of **Standard**, **Exposure** and **Gain** are read-only. The **A** shown on the sun and dial icons signifies that Auto Photometry is enabled. Auto Photometry constantly determines the best Exposure and Gain settings during each read cycle.

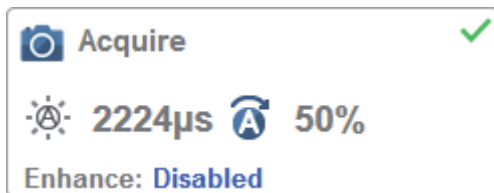

**Auto Photometry**

## Autofocus

**Autofocus** can be enabled and disabled in the **Image Area** using the focus button in the **Device Control Toolbar**, and can be configured in the **Acquire** section of the **Setup** view.

While in **Continuous** mode or **Continuous Auto** mode, the reader can enable or disable Autofocus functionality, allowing it to refocus after a number of no reads. The focus button shows an **A** when Autofocus is enabled. The focus distance is updated on the fly based on the latest refocus settings.

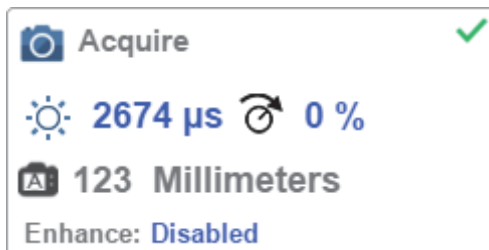



## Spot Focus

If the reader is in **Continuous** mode or **Continuous Auto** (Continuous mode with **Auto Photometry** enabled), you can perform a localized quick focus in the image.

If you click the focus button, the **Autofocus** and **Spot Focus** icons appear:



When you click the Spot Focus icon, the **Select a location in the image to autofocus** message appears:

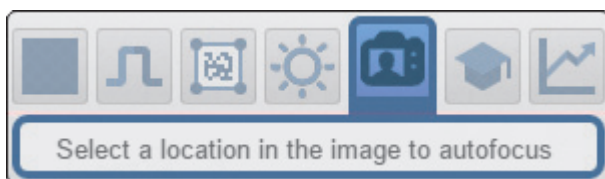

The cursor transforms into crosshairs as shown in the example below. This allows you to select the section of the image in which you want to perform a quick focus.

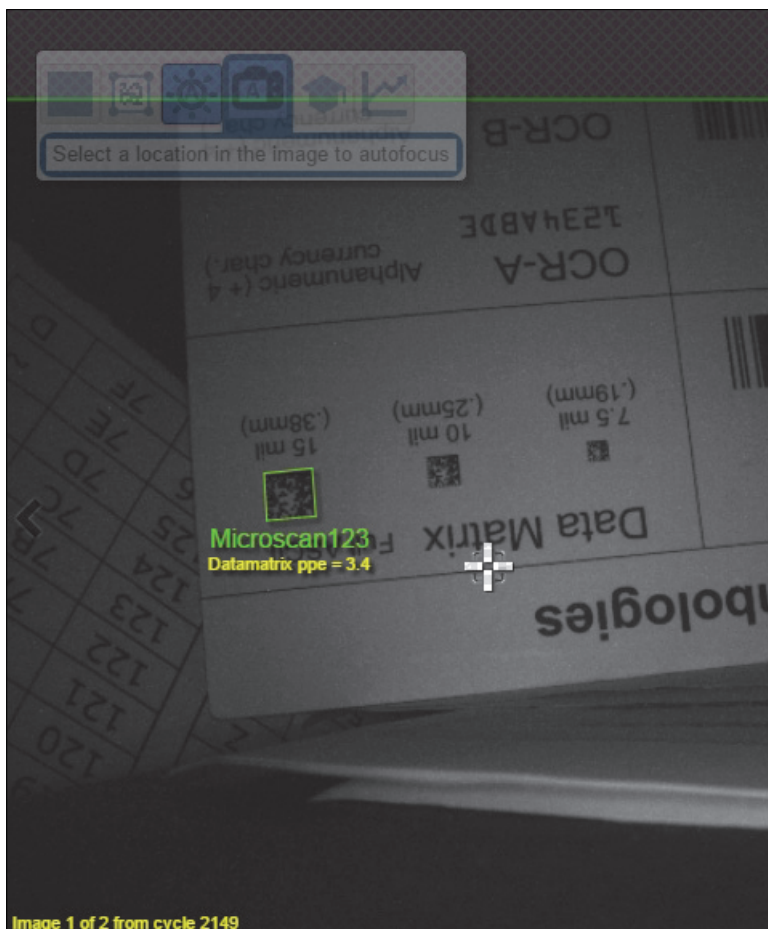

**Note:** If you click the Autofocus button to the left of the Spot Focus button, the reader will switch from Spot Focus to regular Autofocus functionality. If the reader is in **Triggered** mode, only the Spot Focus icon will appear.

## Enhance

The **Enhance** dropdown menu at the bottom of the **Acquire** settings editor allows you to select the method for processing captured images.

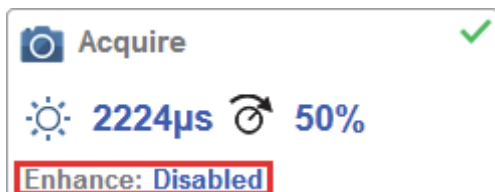

- **Grow Dark**

**Grow Dark** increases the dark cell size of a symbol. It is useful for increasing the dark cell size of a dark-on-light Data Matrix symbol.

- **Shrink Dark**

**Shrink Dark** increases the light cell size of a symbol. It is useful for increasing the light cell size of a light-on-dark Data Matrix symbol.

- **Connect Dark**

**Connect Dark** removes minor light defects of dark cells.

- **Separate Dark**

**Separate Dark** removes minor dark defects of light cells.

## Operator Size

The **Operator Size** dropdown menu determines the size of the area or “pixel neighborhood” in which the enhance operation is being performed.

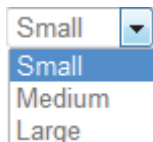

- **Small**

**Small** corresponds to an area of **3 pixels by 3 pixels**.

- **Medium**

**Medium** corresponds to an area of **5 pixels by 5 pixels**.

- **Large**

**Large** corresponds to an area of **7 pixels by 7 pixels**.

## 2-1-12 Configure Symbology and Decode Settings

Clicking the **gear icon** at the bottom of the **Decode** dialog brings up **Symbology Settings**. This allows you to configure every parameter for every available code type.

Data Matrix error correction parameters are shown in this example, but you can configure any parameter for any of the code types supported by WebLink. All parameter changes for all code types take effect immediately.

Symbology Settings		
<b>Data Matrix</b>	☆ ECC 200 Status	Enabled
Code 128	☆ ECC 000 Status	Disabled
Code 39	☆ ECC 050 Status	Disabled
Codabar	☆ ECC 080 Status	Disabled
Code 93	☆ ECC 100 Status	Disabled
Interleaved 2 of 5	☆ ECC 140 Status	Disabled
UPC/EAN	☆ ECC 120 Status	Disabled
PDF417	☆ ECC 130 Status	Disabled
Micro PDF417	<div style="border: 1px solid red; padding: 5px;"> <p><b>Data Matrix error correction parameters are shown in this example, but you can configure any parameter for any of the code types supported by WebLink. All parameter changes for all code types take effect immediately.</b></p> </div>	
BC412		
Pharmacode		
DataBar Expanded		
Postal Symbologies		

## 2-1-13 Format Output and Configure Match String

**Format Output**, when enabled in the **Setup** view, allows you to determine the many ways in which barcode data can be formatted and parsed before it is output as a data string. You can also set **Preamble** and **Postamble** in this dialog.

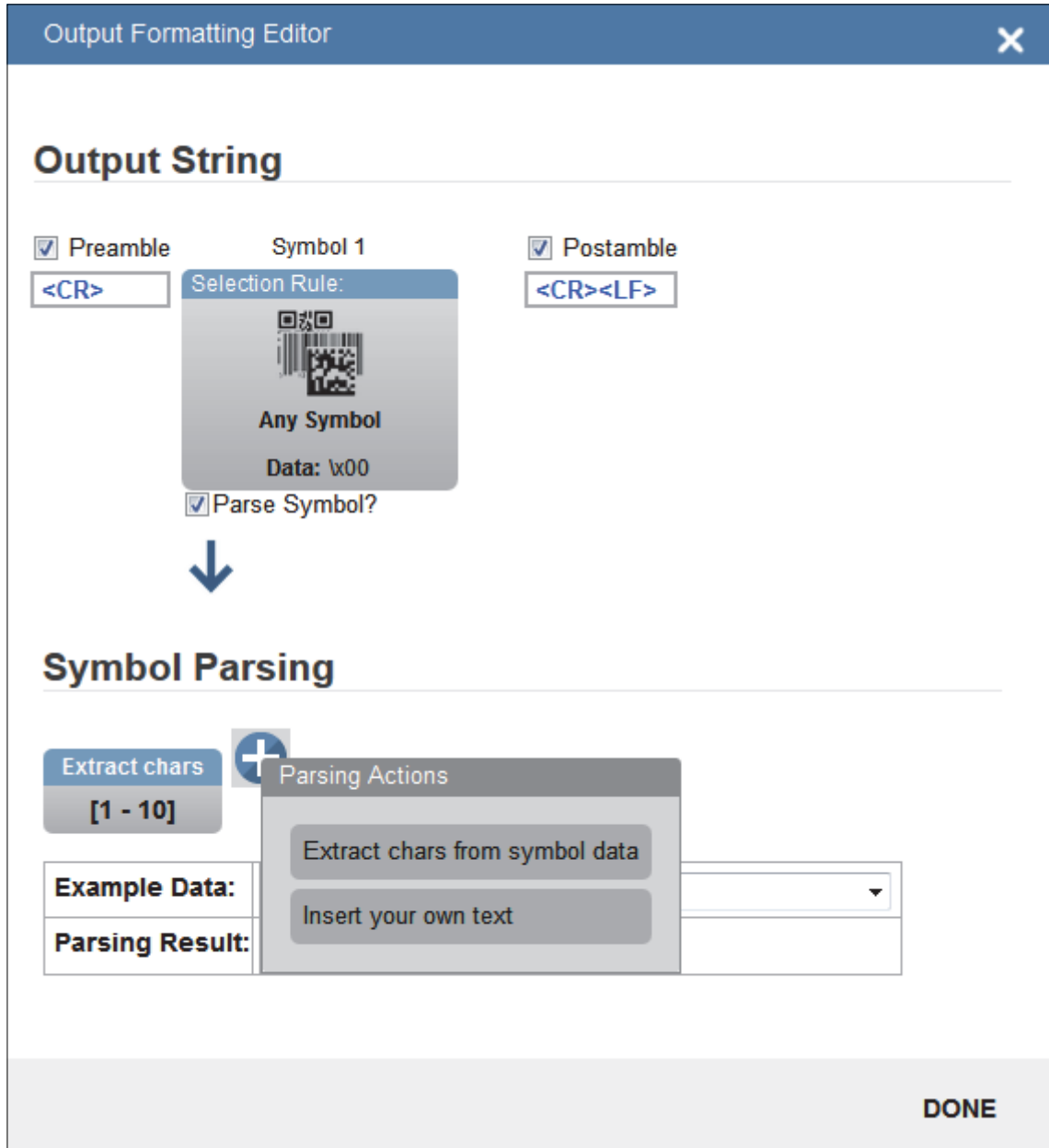

**Match Options** and **Match String Database**, accessible by clicking the **Match String** section in the **Setup** view, allow you to set the match code mode, text output, new master, and match string database.

Match String Editor
✕

### Match Options

Mode: **Standard**

**Settings for Match String:**

Range of Characters to Match Against:

Match All

Partial Match: Start: 0 Length: 1

**Text Output Options:**

Match Replace: **MATCH**

Mismatch Replace: **MISMATCH**

**Train Match String on New Master Input:**

New Master Pin: **Enabled**

### Match String Database

1	MICRO123
+	

**DONE**

## 2-1-14 Configure Output 1, 2, and 3 Settings

Bring up the **Output 1**, **Output 2**, and **Output 3** dialogs by clicking on the **Outputs** section at the lower left of the **Setup** view. For each output you can determine the **Output On** behavior, **Mode**, **Pulse Width**, and **State**. **Outputs 2** and **3** also allow you to determine output behavior based on **Trend Options** parameters or **Verification Options** parameters.

This example shows the dialog that appears when you click **Symbol Quality Options**. A similar dialog would also appear for **Trend Options** under **Output 2**.

**Note:** The **1**, **2**, and **3** output indicators at the lower right of the screen display the results of the last read cycle.

The screenshot shows the 'Digital Output Editor' dialog box. It contains three panels for Output 1, Output 2, and Output 3. Output 1 is set to 'Mismatch or No Read', Output 2 to 'Trend Analysis', and Output 3 to 'Symbol Quality'. All outputs have a 'Pulse' mode and a '500 ms' pulse width. Output 3's 'Symbol Quality Options' are expanded to show the following table:

Symbol Quality Options	
Output on Symbol Contrast	Disabled
Symbol Contrast Threshold	Grade C
Output on Print Growth	Disabled
Print Growth Threshold	Grade C
Output on Axial Non-uniformity	Disabled
Axial Non-uniformity Threshold	Grade C
Output on Unused ECC	Disabled
Unused ECC Threshold	Grade C

## 2-1-15 Run the Application

In the **Run** view, you can observe the progress of the setup as it follows the parameters you have defined. The **right panel** of the UI shows **Counts** for **Cycles**, **Reads**, **No Reads**, and **Mismatches**, as well as **Rate** information for **Capture**, **Decode**, **Overhead**, **Total Read**, and **Trigger Rate**, as well as **Output Data**. A "filmstrip" below the **Image Area** shows each image capture with a **green check mark** for a good read and a **red x** for a no read.

The screenshot displays the OMRON MicroHAWK barcode reader application in the **Run** view. The interface includes a navigation bar with **Start**, **Setup**, and **Run** buttons. The main area shows a live video feed of a barcode being scanned. The right panel displays real-time statistics for counts and rates. Below the video feed is a filmstrip of captured images, each with a green checkmark indicating a successful read. The bottom status bar shows the device ID and IP address.

Counts	
Cycles	1338
Reads	1338
No Read	0
Mismatch	0
Read %	100.00

Rate	
Capture	58.6 ms   17.1/s
Decode	64.1 ms   15.6/s
Overhead	0.0 ms   0
Total Read	93.8 ms   10.7/s
Trig Rate	95.7 ms   10.45/s

**Read Time (ms)**

**Output Data**

http://www.microscan.com/info  
 http://www.microscan.com/info  
 http://www.microscan.com/info  
 http://www.microscan.com/info  
 http://www.microscan.com/info  
 http://www.microscan.com/info  
 http://www.microscan.com/info  
 http://www.microscan.com/info  
 http://www.microscan.com/info  
 http://www.microscan.com/info  
 http://www.microscan.com/info  
 http://www.microscan.com/info  
 http://www.microscan.com/info  
 http://www.microscan.com/info  
 http://www.microscan.com/info

Image 1 of 2 from cycle 533

V430-F3A7BCB | V430 | 192.168.188.2 | 3832779 | 1 2 3





# 3

## Start

The **Start** view is the initial view you will see when the **WebLink** session begins.

---

3-1	Overview .....	3-2
3-2	Assisted Setup .....	3-4
3-3	Reader Information .....	3-5
3-4	Setup Button .....	3-6

## 3-1 Overview

The **Start** view is the initial view you will see when the WebLink session begins. The connected reader is shown, along with its **user-defined name**, **IP address**, **Reader Model**, **Serial Number**, **MAC ID**, **Firmware version**, **WebLink version**, **Sensor**, and **Optics**.

**Note:** The user-defined name must be **19** characters or fewer.

This view also allows you to choose **Assisted Setup**, to **Create a New Setup**, or to **Load a Setup**.

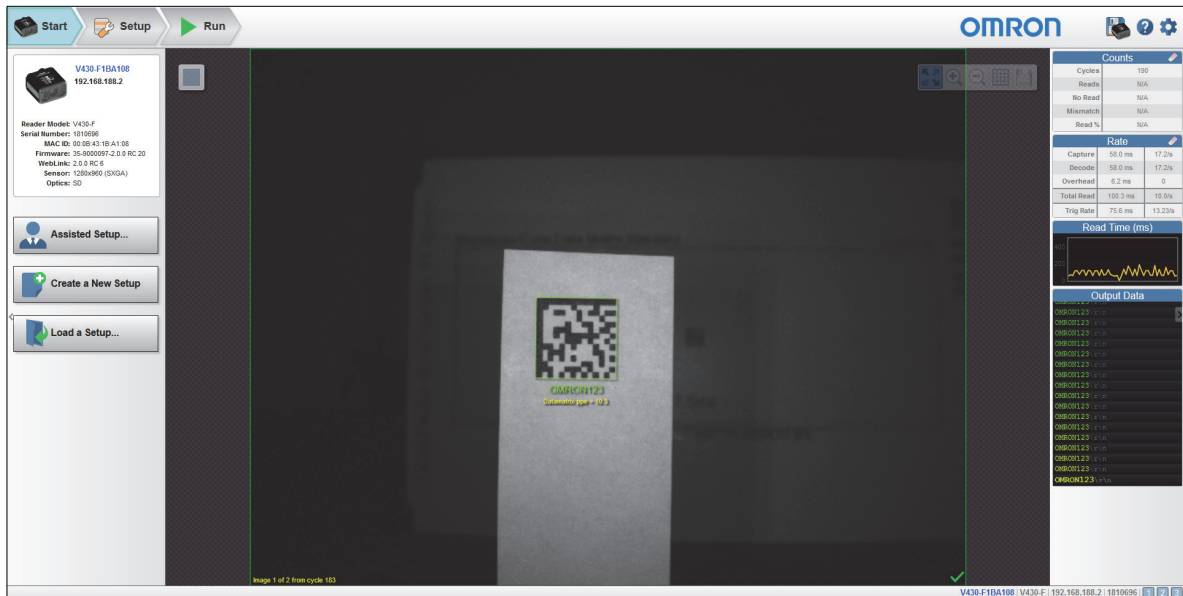

Click the gear icon at the upper right to bring up the **Application Settings** menu. This menu includes several functions: **Save**, **New**, **Load**, **Advanced**, **Language**, **Terminal**, **Beeper**, **Guided Tour**, **Image Storage**, **Restore Default Settings**, **Active Account Management**, and **About WebLink**.

**Note:** The **Enable USB Drive Mode** options only appears when you are using a device that supports USB connectivity.

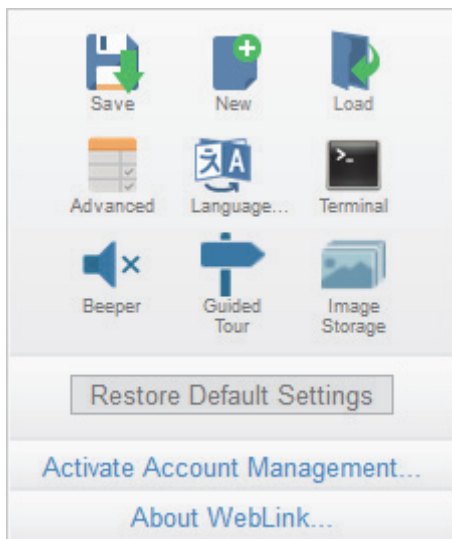

Clicking **About WebLink** opens the dialog shown below, which shows the current **WebLink version**, **Reader Model**, **Serial Number**, **Part Number**, **MAC ID**, **Sensor**, **Firmware version**, **Boot version**, **Decoder**, **Speed**, **Browser**, **Operating System**, and **Screen Resolution**.

**Note:** The information in this dialog is selectable so that you can copy it to a clipboard.

Clicking **Contact us...** takes you to the Omron Microscan website.



## 3-2 Assisted Setup

When you click the **Assisted Setup** button in the **Start** view, a dialog will appear asking you a series of application-based questions. Based on your answers, WebLink generates your initial setup automatically. Once the setup is created, you can fine-tune its parameters in the **Setup** view.

The Assisted Setup dialog is designed to be logical and intuitive, and follows this sequence:

- You are asked which code types you will be reading in your application. Code types can be added by clicking directly in the code type field and selecting them from a dropdown menu.
- Then you are asked how many codes you need to read at once (in a single read cycle). Type the number of codes you need to read directly in the text field or select a number using the up and down arrows.
- You are then given a selection of four application types, which represent the available selections in the **Cycle** area of the **left panel** in the Setup view. The icons represent the **Presentation**, **Continuous**, **Triggered**, and **Start / Stop** Cycle Types.
- The next question is whether or not you need the decoded data to match an existing string of data. This enables or disables **Match String**.
- If the answer to the previous question is **Yes**, a follow-up question appears asking for the exact output string that the decoded data must match. If the answer to the previous question is **No**, the follow-up question does not appear.
- Finally, you are asked if you want to rename the reader. If **Yes**, a text field appears in which you can type the reader's new name. The reader's MAC ID is also shown to the right of the text field.

Click **Create Setup** to configure your WebLink setup automatically based on your answers to the Assisted Setup questions.

**Note:** Reader settings are defaulted when Assisted Setup settings take effect.

Assisted Setup

What code types will you be reading?

Data Matrix QR code Code 128 Code 39 Code 93  
 I2of5 UPC PDF417 Micro PDF DataBar-14  
 DataBar Limited DataBar Extended Micro QR Code

How many codes do you need to read at once? 1

Select the type of application.

Would you like to rename your reader? Yes

Reader Name 18BFA8 00:0B:43:18:BF:A8

CANCEL CREATE SETUP

## 3-3 Reader Information

---

The **Reader Information** section of the left panel of the **Start** view shows your reader's **user-defined name**, **IP address**, **Reader Model**, **Serial Number**, **MAC ID**, **Firmware version**, **WebLink version**, **Sensor**, and **Optics**.

**Note:** The **user-defined name** must be **19** characters or fewer.



**V430-F1A54F8**  
192.168.188.2

Reader Model: V430-F  
Serial Number: 1725688  
MAC ID: 00:0B:43:1A:54:F8  
Firmware: 35-9000097-2.0.0  
WebLink: 2.0.0  
Sensor: 1280x960 (SXGA)  
Optics: UHD

## 3-4 Setup Buttons

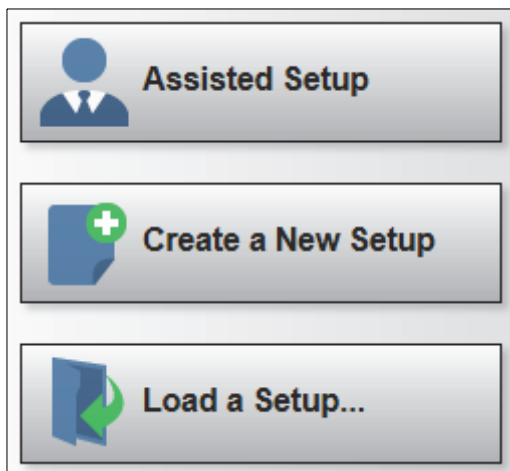

### 3-4-1 Assisted Setup

When you click the **Assisted Setup** button in the **Start** view, a dialog with a **series of questions** about your application will appear. Answering these simple questions allows WebLink to configure your setup for you.

### 3-4-2 Create a New Setup

**New Setup** allows you to create a new setup without using Assisted Setup. When you click the New Setup button, WebLink searches for any differences from default in the reader parameters. If no differences from default are found, you will see the **Setup** view. If differences from default are found, the following alert will appear, allowing you to choose whether to restore the reader to default settings or to cancel the New Setup.

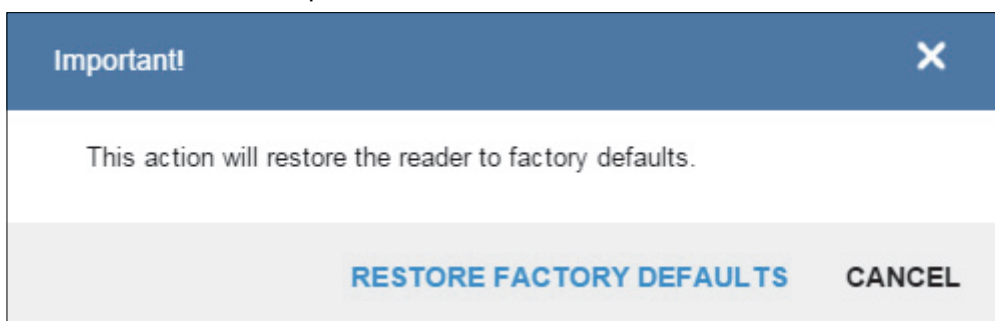

### 3-4-3 Load a Setup

Select **Load Setup** to load an existing **.json** WebLink setup file.

# 4

## Setup

The **Setup** view allows you to configure all aspects of a setup. Multiple discrete sections of the interface give you the ability to set **Autocalibration**, **Cycle**, **Acquire**, **Decode**, **Match String**, **Format Output**, **Outputs**, **Configuration Database**, and **Favorites**.

---

4-1	Autocalibration .....	4-2
4-2	Cycle .....	4-4
4-3	Acquire .....	4-6
4-4	Decode .....	4-9
4-5	Match String .....	4-11
4-6	Format Output .....	4-15
4-7	Outputs .....	4-19
4-8	Configuration Database.....	4-21
4-9	Favorites .....	4-27

## 4-1 Autocalibration

This section describes how to perform **Autocalibration** in the WebLink user interface.

**Autocalibration** automatically determines and sets all key parameters necessary to obtain optimum decode performance on a single easy or difficult symbol.

This feature calculates the optimum settings necessary to achieve the highest decode success rate possible, with the lowest decoding time variance between successive read cycles.

Decode speed is also optimized, but is secondary to high success rate and low read time variance, since the primary factor on a production line is successful and reliable performance.

To begin, navigate to the **Setup** view. If you don't see an image, trigger the reader to capture an image.

**Focus** the reader by clicking the **Focus** icon and selecting the **Target** icon as shown below.



When the reader has finished focusing, click the **Train** button and select the **Target** icon as shown below.

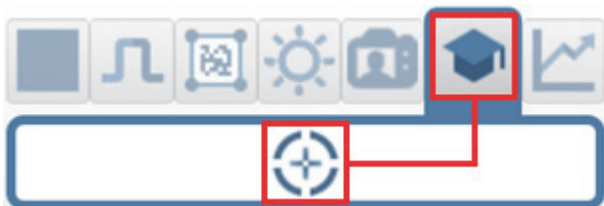

This will activate the **Autocalibration** routine.



Autocalibration progress will be shown in WebLink's **Image Area**.

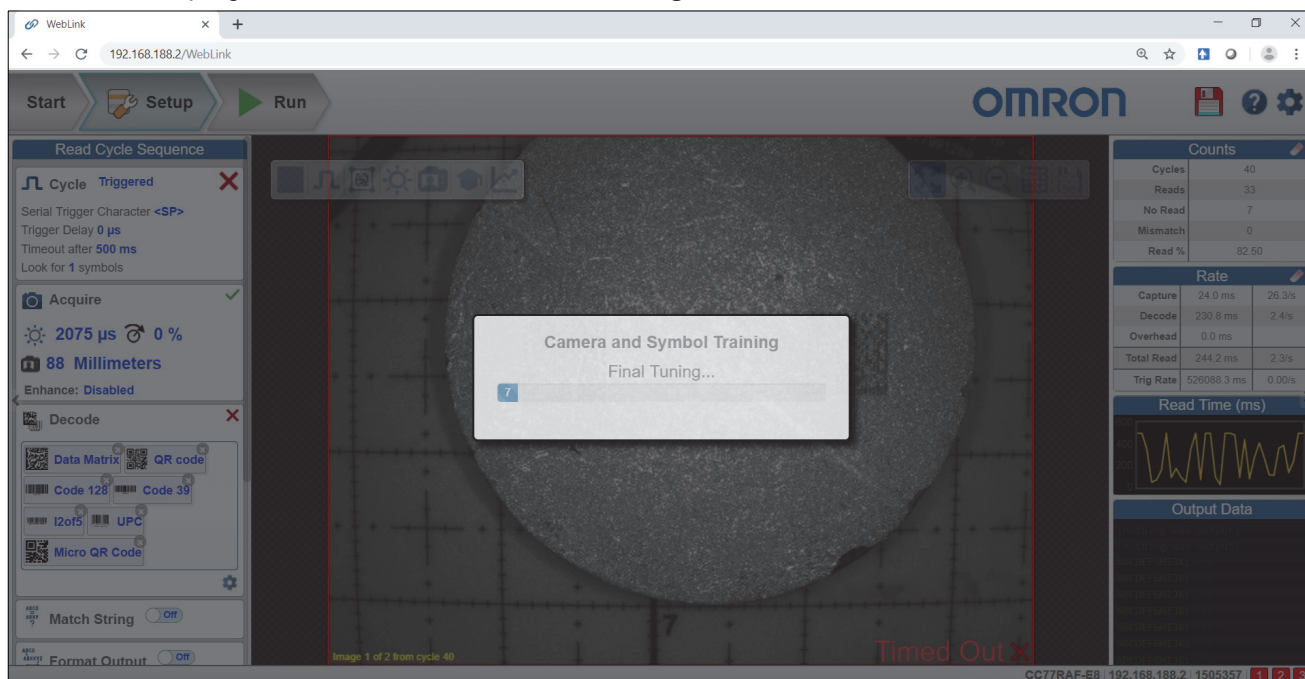

4

When Autocalibration is complete, you will see a message stating whether it has passed or failed. If it passes, the reader's settings will be optimized to decode the symbol on which it has just been calibrated. The following settings may be affected during Autocalibration to enhance decode quality:

- Exposure
- Gain
- Morphology
- Morphology Size
- Binning

You can also use the **Optimize** button at this time to further enhance the decode capability.

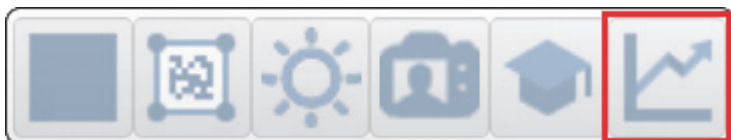

**Additional calibration options:**

- **Gain, Exposure, Symbol Type, and Processing** are not used in the current calibration routine.
- **Window of Interest** can be set. This reduces the amount of time to perform calibration and reduces the area that the code will be searched for in run mode.

Calibration Options	
☆ Gain	Quick Calibrate
☆ Exposure	Quick Calibrate
☆ Focus Position	Quick Focus
☆ Symbol Type	Calibrate
☆ Window of Interest Framing	Don't Calibrate
☆ Window of Interest Margin	75
☆ Linescan Height	64
☆ Processing	Medium

For additional details about reader calibration, including the **Calibration Options** command **<K529>**, see [Appendix E – Calibration](#).

## 4-2 Cycle

The **Cycle** section of the **Setup** view allows you to modify the trigger, determine the number of symbols for the reader to expect, and set **Read Cycle Timeout**. A dropdown menu of various Cycle types provides a variety of options, each with configurable parameters.

### 4-2-1 Presentation

This mode uses **Continuous Read Auto** along with **Continuous Capture Mode** and a **Timeout at End of Read Cycle**. **Green Flash Mode** is set to **Static Presentation** and the **Green Flash Duration** is set to **250 ms**.

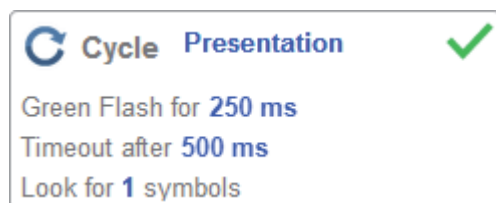

### 4-2-2 Continuous

This mode allows you to set the **Read Cycle Timeout** and the expected **Number of Symbols** from 1 to 100.

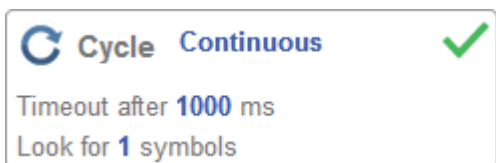

### 4-2-3 Triggered

This mode sets the read cycle to **Serial Data and Edge**, **End of Read Cycle** is set to **Timeout or New Trigger**, and **Capture Mode** is set to **Rapid Capture** with **1 capture**. You can adjust the **Serial Trigger**, **Trigger Delay**, **Timeout**, and **Number of Symbols**.

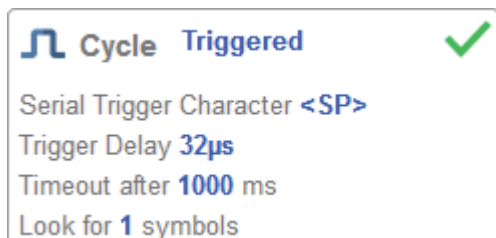

### 4-2-4 Start / Stop

This mode uses **External Level** with a **Read Cycle Timeout** and **Continuous Capture**, allowing you to set **Leading Edge** and **Trailing Edge** as well as the **Serial Trigger** and the **Start and Stop Characters**.

## Serial Trigger (Non-Delimited) Off

When **Serial Trigger** is set to **Off**, the start and stop characters are set to **NULL**, meaning that the trigger is disabled.

## Serial Trigger (Non-Delimited) On

When **Serial Trigger** is set to **On**, the start and stop characters are set to **S** and **E**. When the trigger button is clicked, it will use the current start and stop non-delimited triggers.

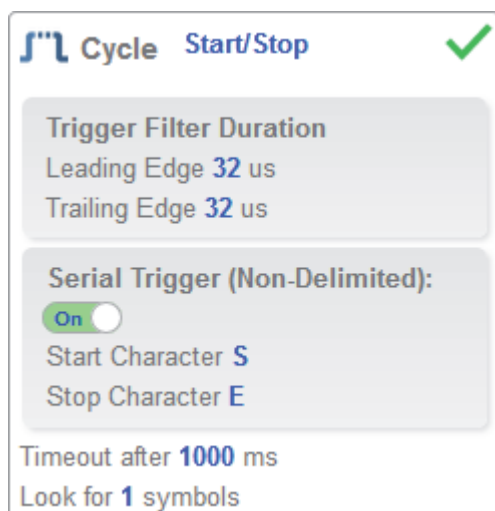

4

## Custom

This mode allows you a wider variety of read cycle scenarios, including **Continuous Read Auto**. Use this mode to select **Trigger** mode and to set **Serial Trigger Character** and **Trigger Delay**; to select **Capture Mode** and to set **Number of Captures**, **Rapid Capture Mode**, and **Delay between Images**; and to select the **End Cycle On** setting as well as **Timeout** and **Number of Symbols**.

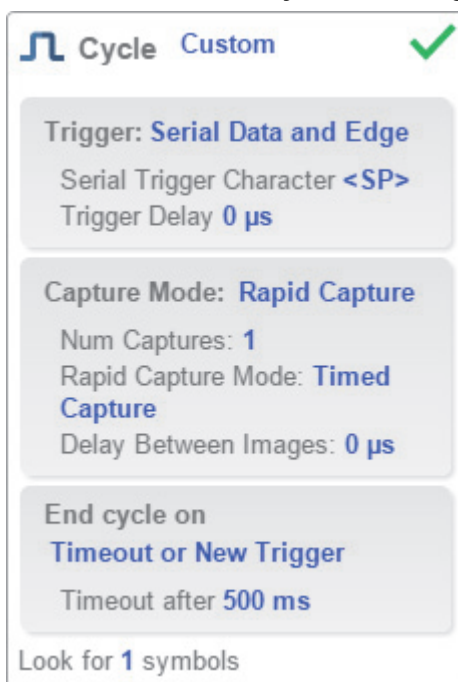

## 4-3 Acquire

**Acquire** settings allow you to set **Exposure** (signified by the sun icon) and **Gain** (signified by the dial and right-pointing arrow icon) in real time. Clicking any of these settings will cause a control to appear, allowing you to modify that setting. Settings take effect immediately.

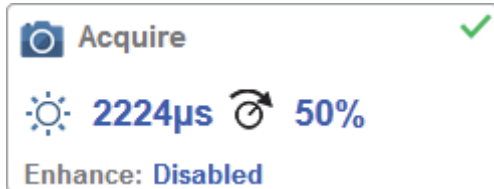

*Standard*

**Important:** There are 4 levels of Gain in SXGA MicroHAWK readers. Each level corresponds to 25 percentage points, or one quarter turn of the Gain dial shown at left.

- Level 1 = 0% to 24%
- Level 2 = 25% to 49%
- Level 3 = 50% to 74%
- Level 4 = 75% to 100%

When **Auto Photometry** is enabled instead of **Standard**, Exposure and Gain are read-only. The **A** shown on the sun and dial icons signifies that Auto Photometry is enabled. Auto Photometry constantly determines the best Exposure and Gain settings during each read cycle.

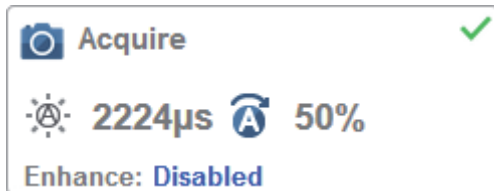

*Auto Photometry*

### 4-3-1 Autofocus

**Autofocus** can be enabled and disabled in the **Image Area** using the focus button in the **Device Control Toolbar**, and can be configured in the **Acquire** section of the **Setup** view.

While in **Continuous** mode or **Continuous Auto** mode, the camera can enable or disable Autofocus functionality, allowing it to refocus after a number of no reads. The focus button shows an **A** when Autofocus is enabled. The focus distance is updated on the fly based on the latest refocus settings.

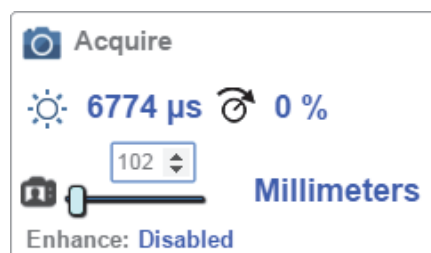
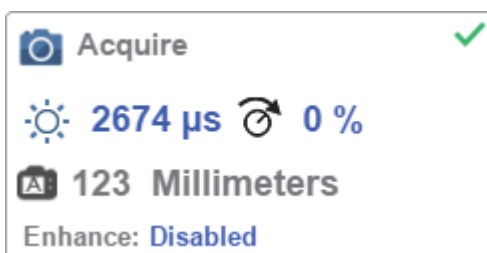

### 4-3-2 Spot Focus

If the camera is in **Continuous** mode or **Continuous Auto** (Continuous mode with **Auto Photometry** enabled), you can perform a localized quick focus in the image.

If you click the focus button, the **Autofocus** and **Spot Focus** icons appear:

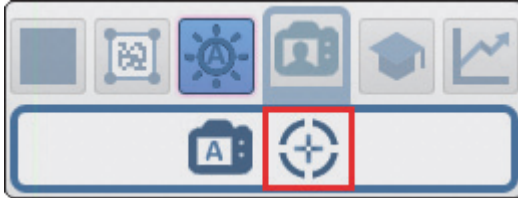

When you click the Spot Focus icon, the **Select a location in the image to autofocus** message appears.

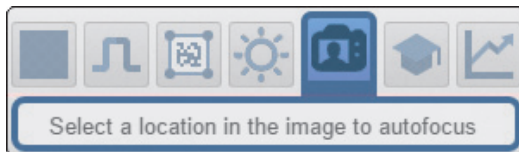

The cursor transforms into crosshairs as shown in the example below. This allows you to select the section of the image in which you want to perform a quick focus.

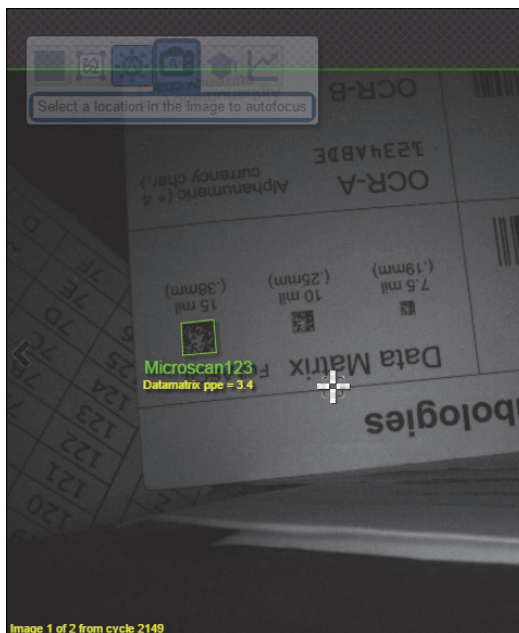

**Note:** If you click the Autofocus button to the left of the Spot Focus button, the reader will switch from Spot Focus to regular Autofocus functionality. If the reader is in **Triggered** mode, only the Spot Focus icon will appear.

### 4-3-3 Enhance

The **Enhance** dropdown menu at the bottom of the **Acquire** editor allows you to select the method for processing captured images.

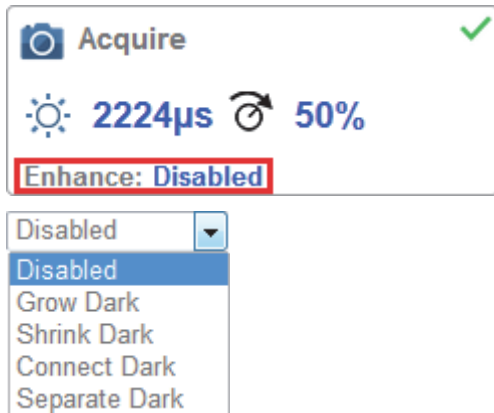

#### Grow Dark

**Grow Dark** increases the dark cell size of a symbol. It is useful for increasing the dark cell size of a dark-on-light Data Matrix symbol.

#### Shrink Dark

**Shrink Dark** increases the light cell size of a symbol. It is useful for increasing the light cell size of a light-on-dark Data Matrix symbol.

#### Connect Dark

**Connect Dark** removes minor light defects of dark cells.

#### Separate Dark

**Separate Dark** removes minor dark defects of light cells.

### 4-3-4 Operator Size

The **Operator Size** dropdown menu determines the size of the area or “pixel neighborhood” in which the enhance operation is being performed.

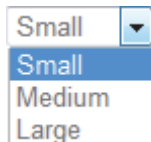

#### Small

**Small** corresponds to an area of **3 pixels by 3 pixels**.

#### Medium

**Medium** corresponds to an area of **5 pixels by 5 pixels**.

#### Large

**Large** corresponds to an area of **7 pixels by 7 pixels**.

## 4-4 Decode

The **Decode** area of the **Setup** view allows you to choose which code types you want to enable, and to configure the parameters for those code types.

See [Symbologies](#) for **Advanced Decoding Parameters**.

### 4-4-1 Code Types and Symbology Settings

In the example below, all code types are enabled.

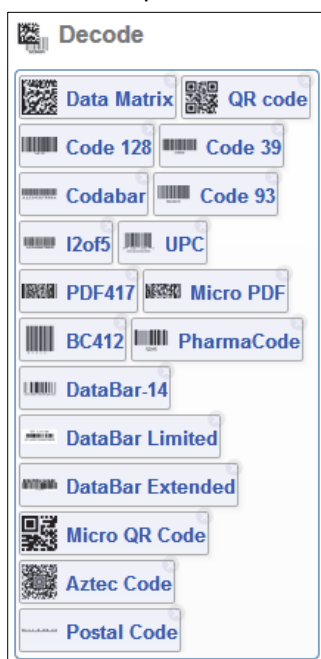

You can add code types by clicking in an empty section of the field where code types are displayed, and then selecting the desired code types from the dropdown menu.

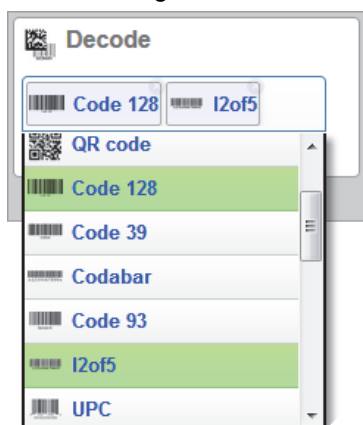

You can also enable one of several postal code options using the **Postal Option** dropdown menu shown below.

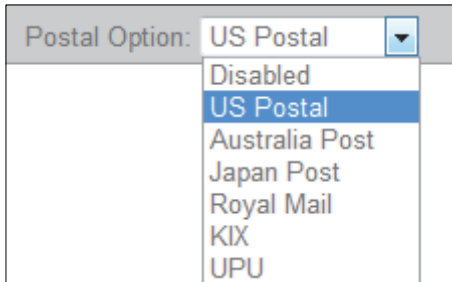

Clicking the **gear icon** at the bottom of the **Decode** section brings up **Symbology Settings**. This allows you to configure every parameter for every available code type.

Data Matrix error correction parameters are shown in this example, but you can configure any parameter for any of the code types in the list shown below. All parameter changes for all code types take effect immediately.

Symbology Settings		
<b>Data Matrix</b>	☆ ECC 200 Status	<b>Enabled</b>
Code 128	☆ ECC 000 Status	<b>Disabled</b>
Code 39	☆ ECC 050 Status	<b>Disabled</b>
Codabar	☆ ECC 080 Status	<b>Disabled</b>
Code 93	☆ ECC 100 Status	<b>Disabled</b>
Interleaved 2 of 5	☆ ECC 140 Status	<b>Disabled</b>
UPC/EAN	☆ ECC 120 Status	<b>Disabled</b>
PDF417	☆ ECC 130 Status	<b>Disabled</b>
Micro PDF417		
BC412		
Pharmacode		
DataBar Expanded		
Postal Symbologies		

**Data Matrix error correction parameters are shown in this example, but you can configure any parameter for any of the code types supported by WebLink. All parameter changes for all code types take effect immediately.**



## 4-5 Match String

**Match String** will attempt to match to the decoded data. (It will not attempt to match to the Formatted Output Data).

**Note:** **Match String** can only be used in **Triggered**, **Start/Stop**, and **Custom** modes. It cannot be used in Presentation or Continuous modes.

To open the **Match String Editor**, go to the **Setup** view and turn Match String **ON** as shown below.

Then click on the **Mode** link (shown as **Standard** in the example below) to open the **Match String Editor**.

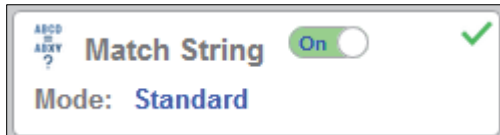

In the **Match String Editor**, click on the **Mode** link under **Match Options** to select your **Match String Mode** – **Standard**, **Wildcard**, or **Sequential**.

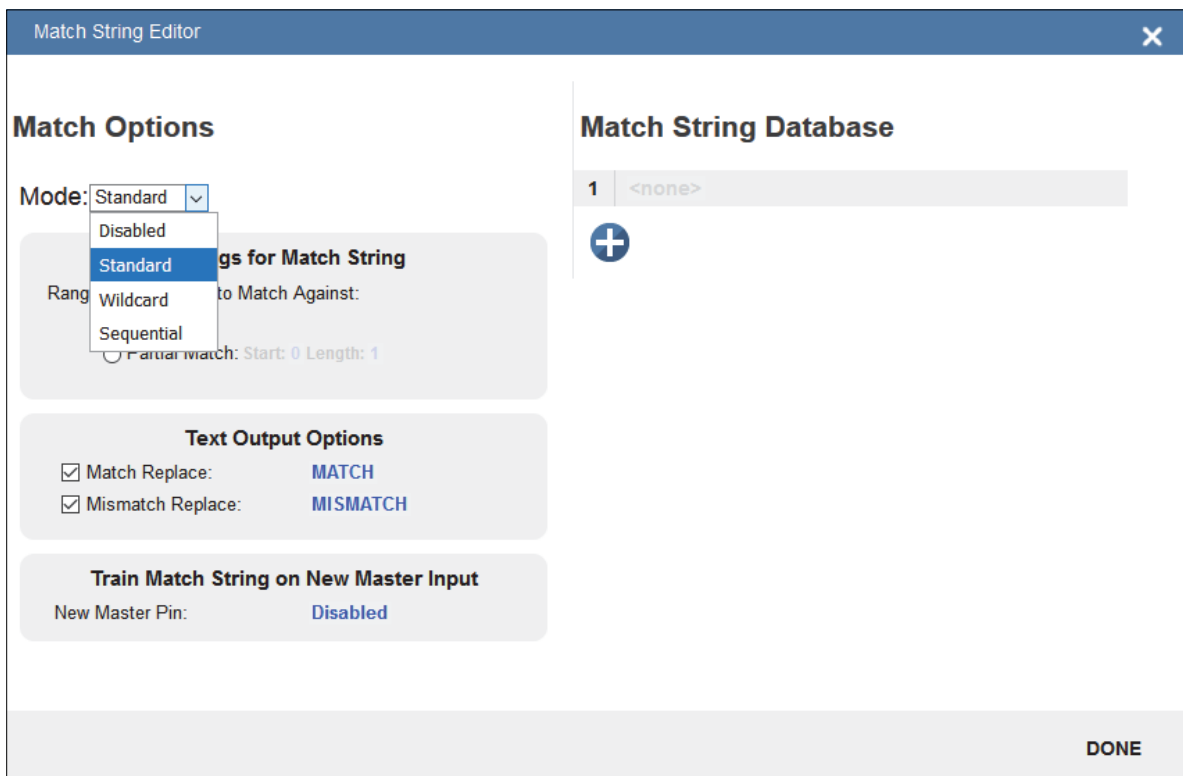

## 4-5-1 Standard and Wildcard Modes

**Standard** mode allows you to match total or partial barcodes by defining strings in the **Match String Database**.

**Wildcard** mode allows you to create custom matches using wildcards and placeholders.

A **wildcard** is a single character that can act as **0** or more characters. A **placeholder** is a character that can substitute for exactly one character.

### Standard Mode

Select **Match All** under **Settings for Match String**.

Under **Match String Database**, input the exact decoded data as it appears when you scan the barcode. Match All is working correctly if it successfully matches a barcode of the same length and character sequence that you input in the Match String Database.

Now select **Partial Match** under **Settings for Match String**. Choose a start position and length based on the barcode you're scanning.

Partial Match works by using the Start and Length fields and attempting to match the exact portion of text defined in the Match String Database in that location.

For example, if the decoded symbol data is **1234567**, Start=**1**, Length=**2**, and the input in the Match String Database is **12**, the match would be successful because characters **12** are in the portion of the barcode data defined by the Start and Length fields.

Try achieving several of your own Partial Matches on several portions of your barcode data, changing the Start and Length fields each time.

In both **Match All** and **Partial Match**, you can output custom text upon a successful or unsuccessful match. These fields can be activated and edited by clicking on **Match Replace** and **Mismatch Replace**.

If you enter several inputs into the **Match String Database**, the application will attempt to match all of them. If one match is successful, then the other failures are ignored, and the match is considered successful.

## Wildcard Mode

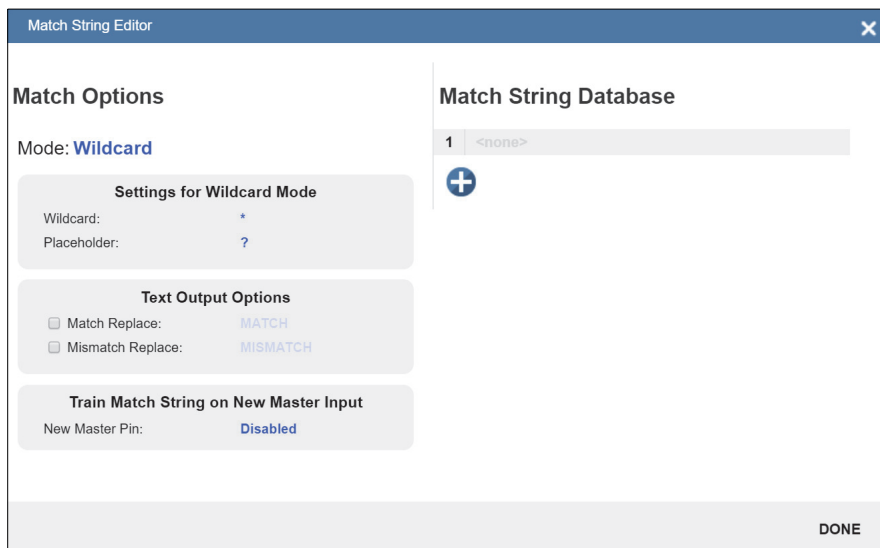

**Wildcard** mode gives you the ability to use wildcards and placeholders to search for matches. By default the Wildcard is \* and the Placeholder is ?

You can use these wildcard and placeholder definitions when they input text into the **Match String Database**.

A **wildcard** represents one or more characters of any type. For instance, **\*TEST\*** looks for the text "TEST" in barcode data with any amount of characters before or after it.

**\*TEST** looks for the text "TEST" in barcode data with any number of characters before it, but "TEST" at the end.

**TEST\*** looks for the text "TEST" at the beginning of the barcode data, with any number of characters after it.

If you had a barcode with data **1234567** and tried to match to the entire data string using **123\***, you would have a successful match.

If you tried to match that same barcode data using **\*123**, you would be unsuccessful because **123** appears at the beginning of the barcode. It's important to remember that the wildcard character \* always stands for one or more unknown characters.

Now try to match a portion of the barcode you're scanning by using **\*YOURTEXT\***. If the text "YOURTEXT" appears somewhere in the middle of the barcode, the match will be successful.

A **placeholder** represents one character of any type. For example, **???TEST** tries to match a barcode that contains three characters of any type followed by the text "TEST". **???TE?T** attempts to match a barcode that contains an unknown character where the 'S' previously appeared.

Placeholders and wildcards can also be used together in the **Match String Database** input fields. The concepts of both are still the same: a wildcard represents one or more unknown character, and a placeholder represents exactly one unknown character.

An example of a complex match using wildcards is shown below. Recall that wildcards and placeholders are \* and ? by default, but they can be redefined.

## Match String Database

1 \*Are\*This\*US?????



The barcode data the example above was attempting to match was **EN-1234\_AreYouReadingThis en\_US 1234**.

The logic of this match is diagrammed below.

**[ANY AMOUNT OF CHARACTERS][ARE][ANY AMOUNT OF CHARACTERS][THIS][ANY AMOUNT OF CHARACTERS][US][5 CHARACTERS]**

\* = Any amount of characters (**EN-1234\_** in this case)

**Are**

\* = Any amount of characters (**YouReading** in this case)

**This**

\* = Any amount of characters (**en\_** in this case)

**US**

**?????** = **5 Characters** (**1234** in this case)

## Sequential Mode

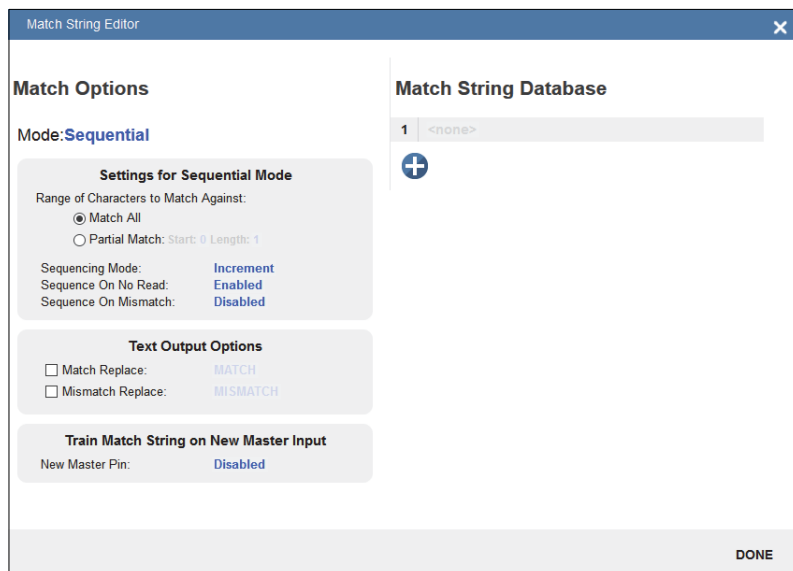

**Sequential** mode instructs the reader to sequence after each match and to compare symbols or portions of symbols for sequential numbers.

**Note:** If **Matchcode Type** is set to **Sequential**, the reader will behave as if **Number of Symbols** were set to **1**, regardless of the user-defined configuration.

## 4-6 Format Output

The purpose of **Format Output** is to modify decoded barcode data by inserting or extracting portions of decoded strings. You can access Format Output in the left panel of the Setup view.



**Format:** `{S1}\r\n`

There are several ways to modify decoded barcode data using Format Output:

**Preamble/Postamble:** Applies defined text to the beginning or end of a barcode if the checkbox is selected. Preambles and Postambles are not overridden by other rules, such as Character Replace.

**Parse Symbol: Symbology Type, Data, Length, and Database Index** can be accessed by clicking on the Selection Rule images. You can define a match just as you would in the Match String editor using wildcard and placeholder rules.

**Symbol Parsing:** Extract characters from symbol data or insert your own text. Click the **+** icon after checking the **Parse Symbol** checkbox to access symbol parsing functionality. Up to 30 parsing rules can be applied, and the results will display in the **Parsing Result** box.

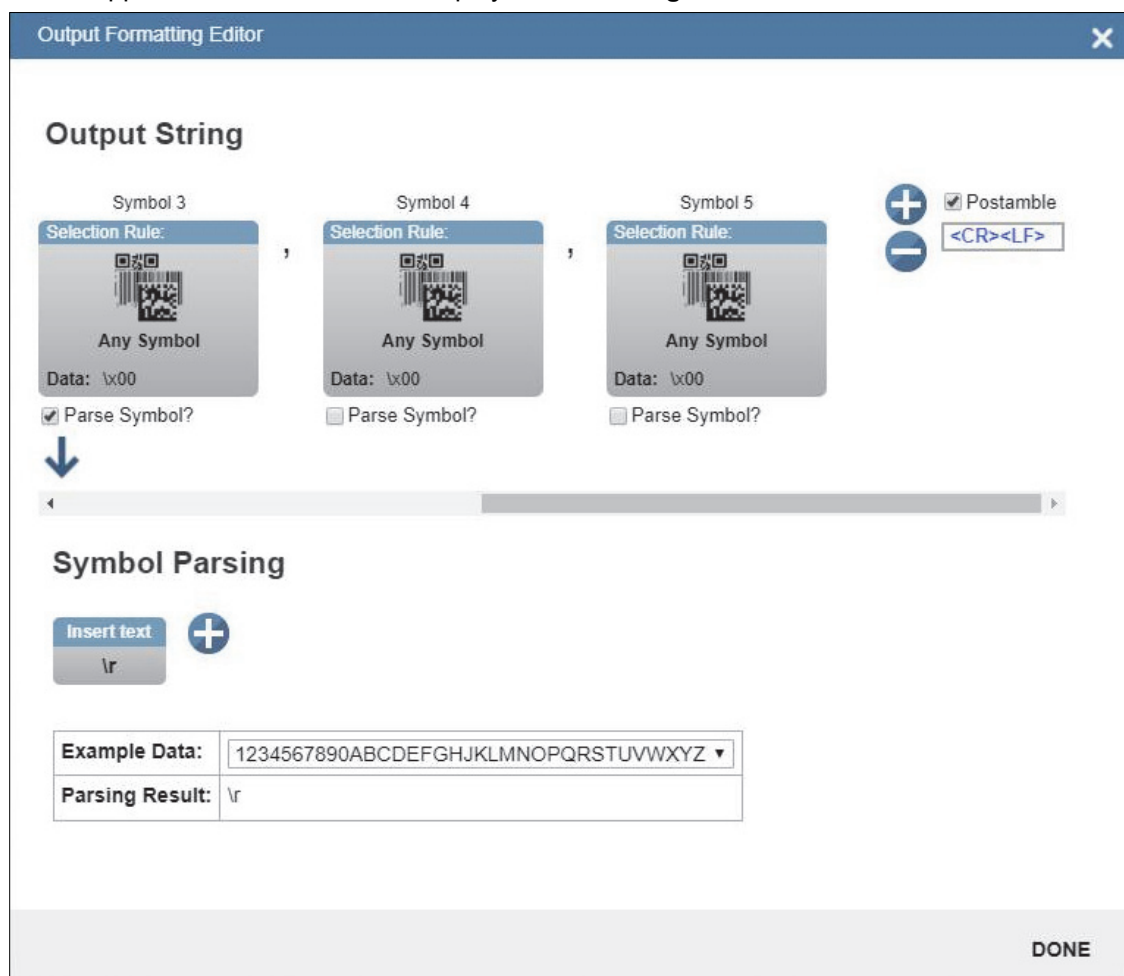

In the image above, under **Output String**, you can see that “filters” are present between the Preamble and Postamble. Click on each filter to define it. The most important field here is **Data**. The rules for entering characters in the Data field are similar to those for entering characters in the Match String Database. You simply use a combination of text, wildcards, and placeholders to attempt to match a barcode.

You can define multiple filters, and the **Symbol Parsing** actions shown in the example above (**Extract characters from symbol data** and **Insert your own text**) will apply if the filter definition matches a decode, just as in the Match String Editor. The filter is simply a way to apply Symbol Parsing rules to specific barcodes. If the filter matches the barcode, then the extract and insert rules will apply.

If multiple filters are defined, only a single filter that matches the barcode data is needed for the rules to be applied. Multiple defined filters do not mean that all filters must match to activate parsing rules.



Click on the **+** button to define a new filter.

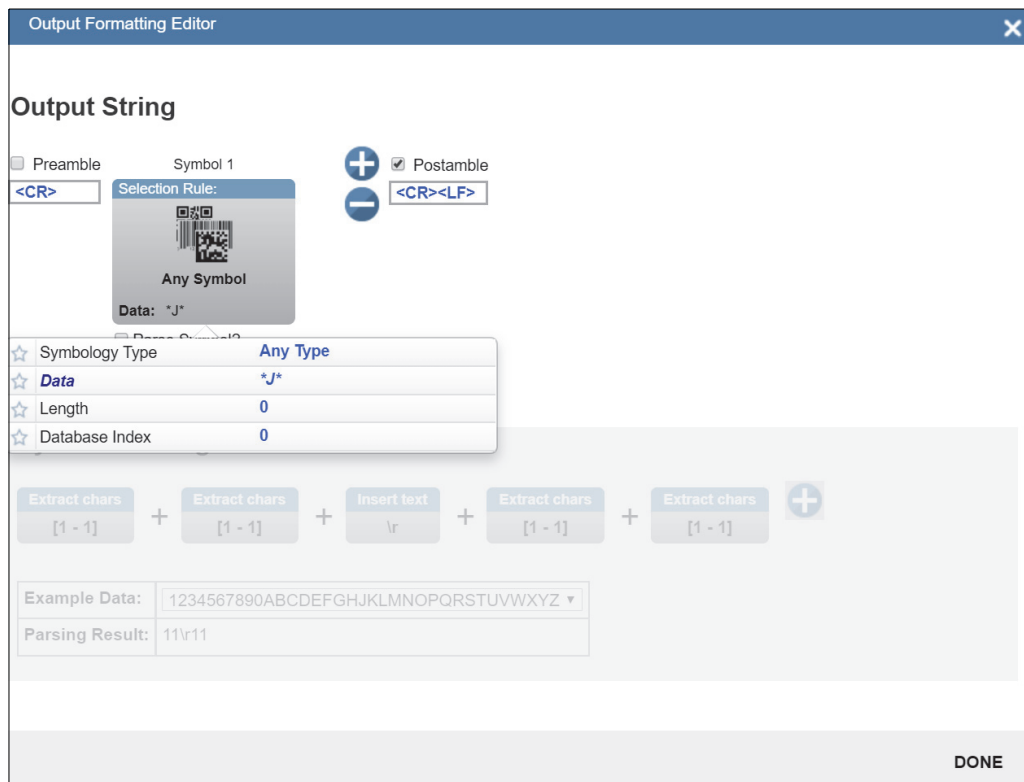

Click on the filter to open the popup, giving you access to **Symbology Type**, **Data**, **Length**, and **Database Index**.

Try changing the Data field to search for a section of a barcode using wildcard / placeholder rules.

In this example, the filter will match any barcode that contains a J.

**Output Formatting Editor**

**Output String**

Preamble  Postamble

<CR> Selection Rule: Any Symbol Data: \*J\*  Parse Symbol?

**Symbol Parsing**

Extract chars [1 - 1] + Insert text HELLO + Extract chars [5 - 6]

Example Data: 1234567890ABCDEF...XYZ  
 Parsing Result: 1HELLO56

DONE

Select the **Parse Symbol** checkbox to activate the rules for this filter. In the **Symbol Parsing** section, try defining some rules.

In the example above, any barcode that contains a J will have the 3 Symbol Parsing rules above applied to it.

You can also tell the system to search for "Any Symbol" or for only specific symbologies.

**Output Formatting Editor**

**Output String**

Preamble  Postamble

<CR> Selection Rule: I2of5 Data: \*J\*  Parse Symbol?

Symbology Type: I2of5

Data: \*J\*

Length: 0

Database Index: 0

Extract chars [1 - 1] + Insert text HELLO + Extract chars [5 - 6]

Example Data: 1234567890ABCDEF...XYZ  
 Parsing Result: 1HELLO56

DONE

Now you can modify your filter so that the "any J" rule only applies to Interleaved 2 of 5 symbols. You could potentially define a custom rule set for several different symbologies.

### 4-6-1 Replace Character

Format Output also has a **Replace Character** feature. You can access the Replace Character feature by clicking on the **Replacements** link in the Format Output editor.

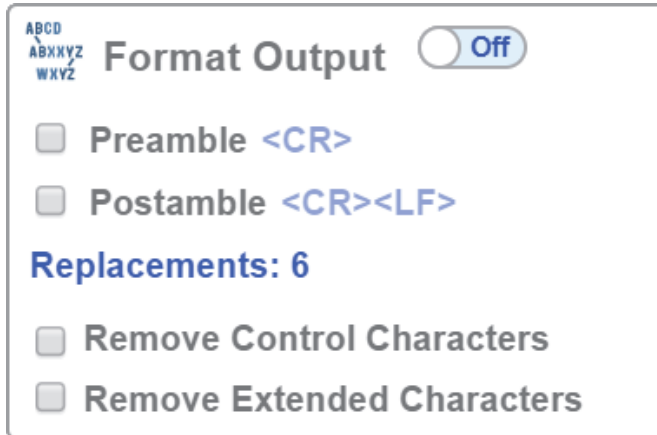

Before clicking on the Replacements link, note the two other boxes below the link: **Remove Control Characters** and **Remove Extended Characters**. These are used to remove all ASCII control characters and ASCII extended characters from decoded barcode data. A complete ASCII table is available for reference [here](#). Control characters are defined as **1-31**, and extended characters are defined as **127-255**. Click on the Replacements link to open the replacements dialog shown below.

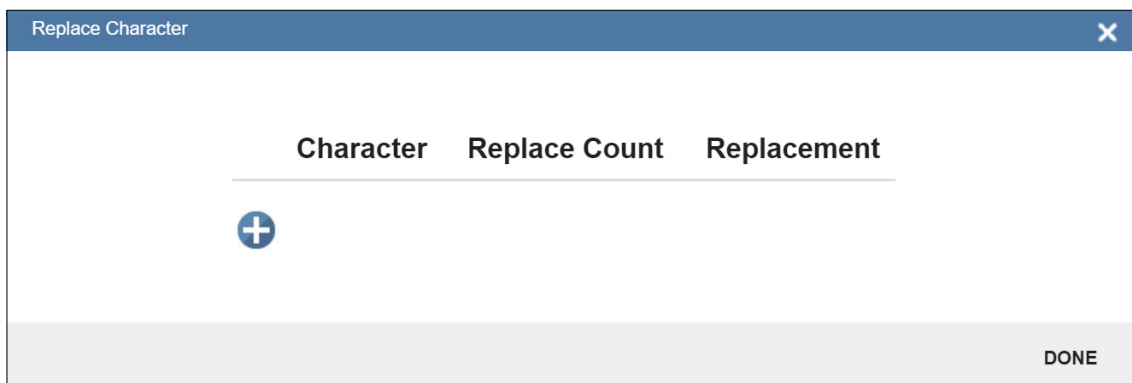

**Character:** The character that you want to replace.

**Replace Count:** How many characters you want the character to be replaced with. Valid options are **0**, **1**, and **2**.

**Replacement:** The character(s) that you want to replace the character with.

When you replace a character with one or more different characters, the results will be displayed in the Output Data window in the lower right panel of the WebLink user interface. Up to **25** character replacements can be defined. If duplicates are defined, an error message will appear, and only the first definition will be applied.

You can enter ASCII control characters by selecting the link below the input box. You can also enter extended ASCII characters by entering **\xHexadecimal** – for example: **\xFF**.

The number of replacements that you've defined are counted in the Replacements link in the Format Output editor.



## 4-7 Outputs

Bring up the **Output 1**, **Output 2**, and **Output 3** dialogs by clicking on the **Outputs** section at the lower left of the **Setup** view. For each output you can determine the **Output On** behavior, **Mode**, **Pulse Width**, and **State**. **Outputs 2** and **3** also allow you to determine output behavior based on **Trend Options** parameters or **Symbol Quality Options** parameters.

This example shows the dialog that appears when you click **Symbol Quality Options**. A similar dialog would also appear for **Trend Options** under **Output 2**.

**Note:** The **1**, **2**, and **3** **output indicators** at the lower right of the screen display the results of the last read cycle.

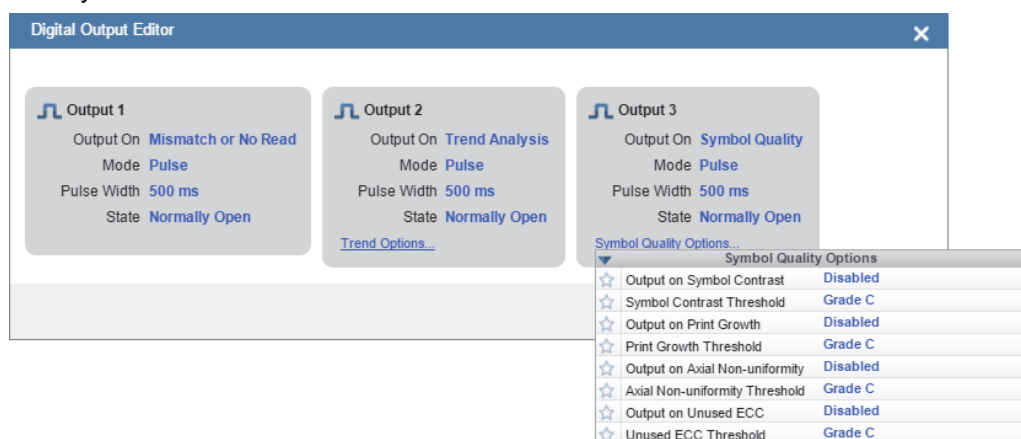

4

### 4-7-1 Output On

**Output On** provides discrete signalling to host software to control external devices such as PLCs and relays. It is useful for routing, sorting, and to prevent mis-packaging and mis-routing. This option allows you to set the conditions under which an output (or outputs) will be activated.

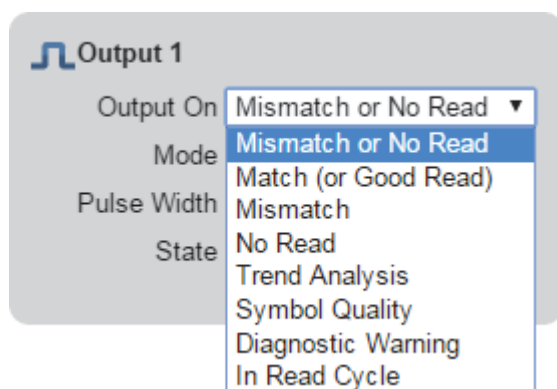

### 4-7-2 Mode

**Output Mode** sets the condition in which the discrete output is de-activated.

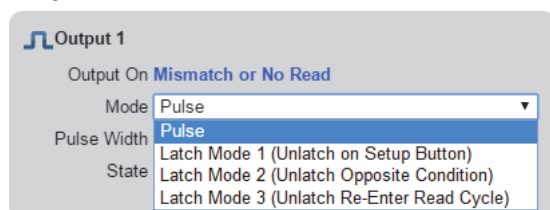

### 4-7-3 Pulse Width

**Pulse Width** sets the time in milliseconds that the discrete output remains active.

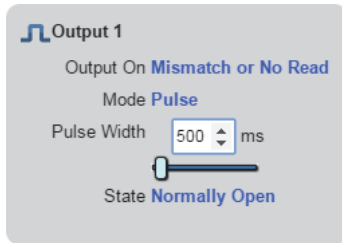

### 4-7-4 State

**Output State** allows you to set the active electrical state of the discrete output to **Normally Open** or **Normally Closed**.

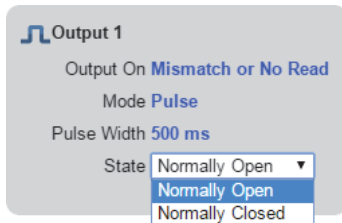

### 4-7-5 Triggered Outputs

**Triggered Outputs** show when outputs are triggered and give you the ability to trigger outputs manually.

**Outputs 1 - 3** are located in the lower right corner of the user interface. They function both as buttons that trigger whichever output you click, and as a display that shows which output is currently being triggered. In the example below, output 2 is being triggered.

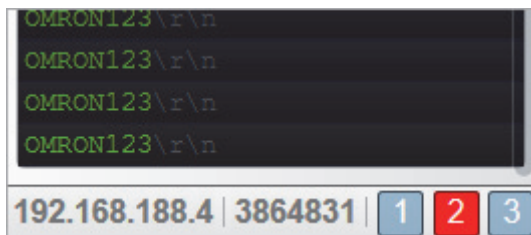

**Note:** These three output indicators display the results of the last read cycle.

## 4-8 Configuration Database

WebLink's **Configuration Database** is a system that uses two or more unique camera configurations that are automatically attempted during a read cycle. It allows for multiple camera changes to be made without interaction from the user. WebLink is used to configure the database settings and verify that all the database indexes are working correctly.

The Configuration Database can be used to fine-tune the reader's performance in your application. It can run multiple decode options in a single read cycle. You can enable Configuration Database and define the number of configurations in **Advanced Settings**. Configurations are set up individually and saved individually. Configuration database is set up in the **Setup** tab and tested in the **Run** tab. Virtually all **Acquire** and **Decode** settings can be individualized per database entry. Clicking the gear icon shows a view of all database settings. Settings can be based on Windows of Interest (WOIs), meaning a new picture is taken for each decode. Settings can also be based on Regions of Interest (ROIs), meaning decodes are attempted on a single image.

**Important: Auto Photometry** should be disabled while using the Configuration Database.

The Configuration Database is useful in applications where:

- More than one symbol type is present;
- A symbol may require different photometry settings to decode;
- Symbols are presented at different depths;
- Multiple symbols with the same data need to be decoded;
- Multiple symbols need to be read in a specific order.

### 4-8-1 Overview of Setup Process

Use WebLink to define the number of active database indexes, located in the **Advanced Settings**.

Use Weblink to configure each of the database indexes by selecting them in the **Setup** view.

#### Tips

- The indexes are not cycled in Setup mode. Switch to Run mode for read cycle testing.
- Set the Number of Symbols to match the number of barcodes you need to decode.
- If decoding multiple barcodes in the same image, make the following changes in **Advanced Settings > Configuration Database**:
  - **Image Process Looping**: Enabled
  - **Image Dimensions**: Region of Interest
- Save each index configuration by clicking on the database icons when done.
- Index number is only output in Run mode if enabled.
- Save settings to the flash memory of the reader when all the indexes in the Configuration Database have been defined for the application.

### 4-8-2 Start and Run Views

You can use **Assisted Setup**, **Create a New Setup**, and **Load a Setup**, along with **Advanced Settings**, to manipulate reader settings.

**Note: Assisted Setup** and **Create a New Setup** will both default the reader.

**Note: Advanced Settings**, while in the **Start** and **Run** views, allows you to manipulate all reader settings except the individual Configuration Database index settings. The settings that are shared between the global and Configuration Database index are ignored by the reader. While in the **Setup** view, the reader pauses the Configuration Database and any changes to the shared settings can be saved into any of the available Configuration Database indexes.

While in the **Start** and **Run** views, you can see which database decoded the symbol:



### 4-8-3 Setup View

The **Setup** view displays a **Configuration Database** section that allows you to add and remove active indexes to and from the database. It also allows you to select specific indexes to modify.

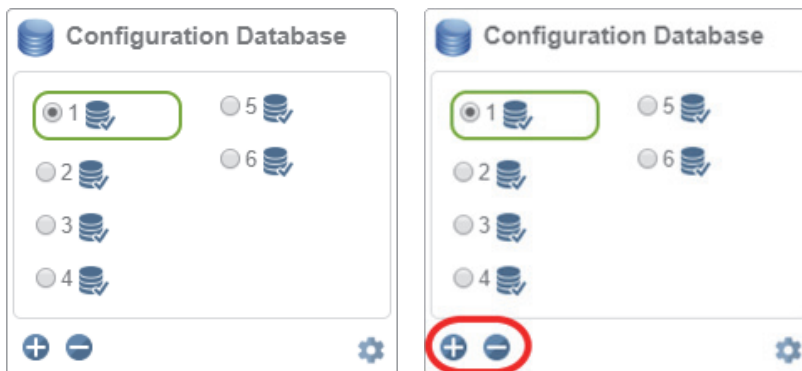

Once you change settings, you can then save to any index by clicking the **Save** button available for each index.



**Note:** The Save button icons are blue for each index by default. In the example below, settings were saved to the 6th index. The Save button will continue to appear green until another setting is sent to the reader.

## 4-8-4 Configuration Database Settings Dialog

You can also access the extra Configuration Database in a popup dialog by clicking the **Extra Settings** gear icon. This provides a read-only view of the Configuration Database showing all available settings. It also includes the Advanced Settings that are available in the Advanced Settings dialog.



## 4-8-5 WOI / ROI

When you click **WOI**, the Configuration Database uses the **Top**, **Left**, **Width**, and **Height** values as **Window of Interest** values. When you click **ROI**, the Configuration Database will use **Top**, **Left**, **Width**, and **Height** values as **Region of Interest** values.

Configuration Database												
Active Indexes		2		Switch Mode		Number of Image Frames		1				
Sort Index Positions on Good Reads		No										
Capture Settings					WOI		ROI		Processing Settings			
	Shutter...	Gain	Focus	Pixel ...	Top	Left	Wid...	Hei...	Sy...	Morph...	Mor...	
1	0	0	105	Disabled	0	0	424	1280	124...	Disabled	Small	
2	3525	0	106	Disabled	418	0	424	1272	124...	Disabled	Small	
3	2500	0	50	Disabled	0	0	960	1280	0	Disabled	Small	
4	2500	0	50	Disabled	0	0	960	1280	0	Disabled	Small	
5	2500	0	50	Disabled	0	0	960	1280	0	Disabled	Small	
6	2500	0	50	Disabled	0	0	960	1280	0	Disabled	Small	
7	2500	0	50	Disabled	0	0	960	1280	0	Disabled	Small	

Capture for Every Index  No      Show Database Index in Output  No

## 4-8-6 Advanced Settings Configuration Database

The **Advanced Settings** dialog shows the extra configuration settings not present in the Configuration Database in the left panel of the WebLink user interface. This is where you would enable the Configuration Database if it isn't already enabled.

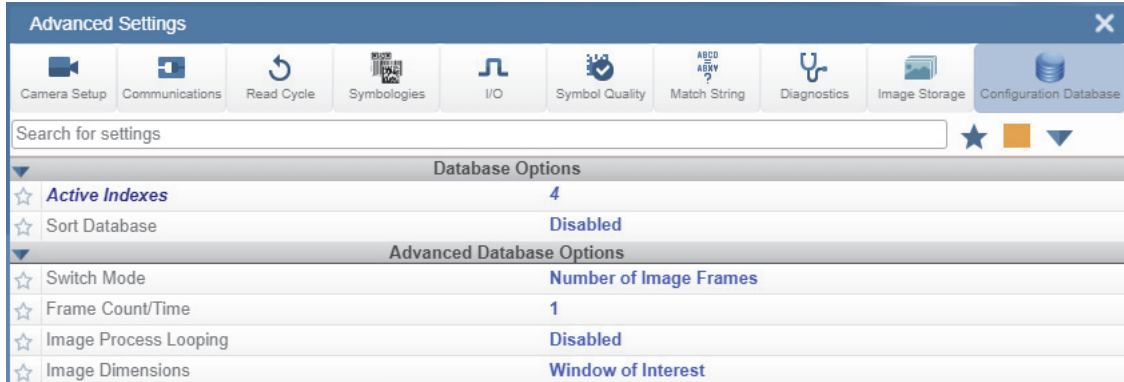

If you enable **Sort Database**, a warning will appear in the Configuration Database section of the left panel.

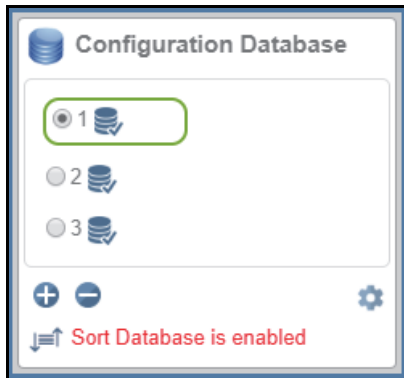

**Note:** The primary way to enable the Configuration Database in the WebLink user interface is to open the **Advanced Settings** dialog and increase the number of **Active Indexes**. An alternate option is to use the **Terminal** and set the index count using the **<K252>** command. If there are no Active Indexes, the Configuration Database view is hidden. Once they are available, either via Advanced Settings or Terminal, the Configuration Database view will appear. If you remove the last index, a warning dialog will appear:

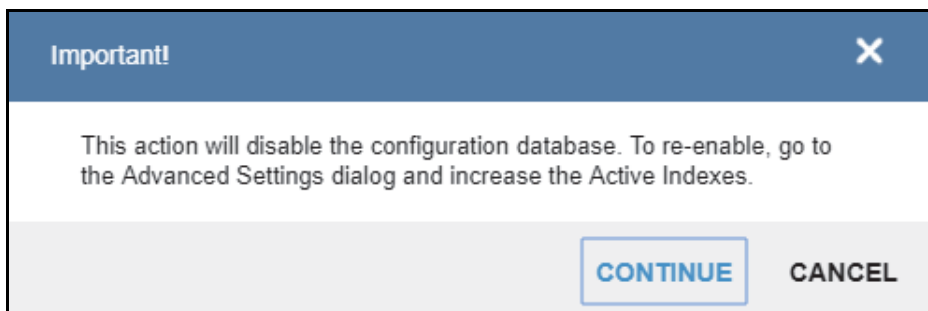

The user interface shows which settings are affected by the Configuration Database using dark blue highlighting around the Acquire and Decode steps.

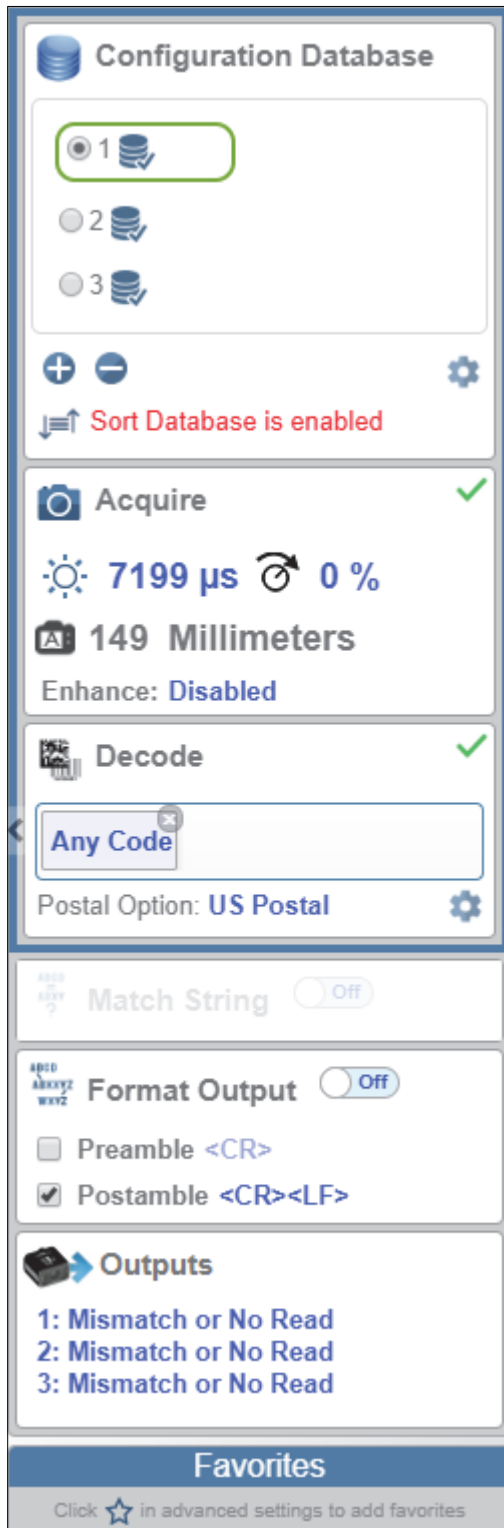

### 4-8-7 Additional Features

If you are in **Rapid Capture Mode** and have fewer captures than the Configuration Database has Active Indexes, the extra Active Indexes will not be triggered. A warning icon will appear if this occurs.

Cycle Custom

Trigger: Continuous Read Auto

Capture Mode: Rapid Capture

Num Captures: 3

Rapid Capture Mode: Timed Capture

Delay Between Images: 0 μs

Make sure the capture count is greater than the configuration database active index count.

If you remove an index that is selected (4), WebLink will select and load index 1.

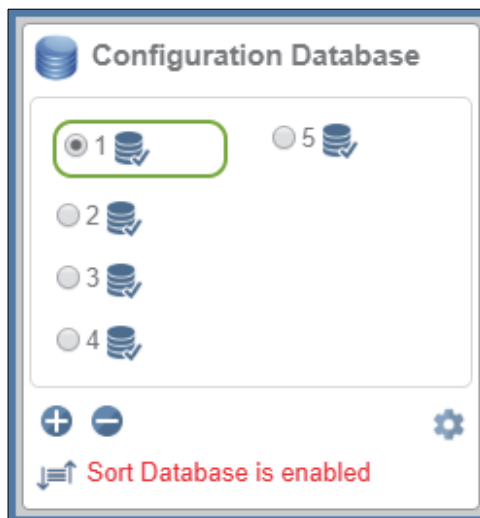
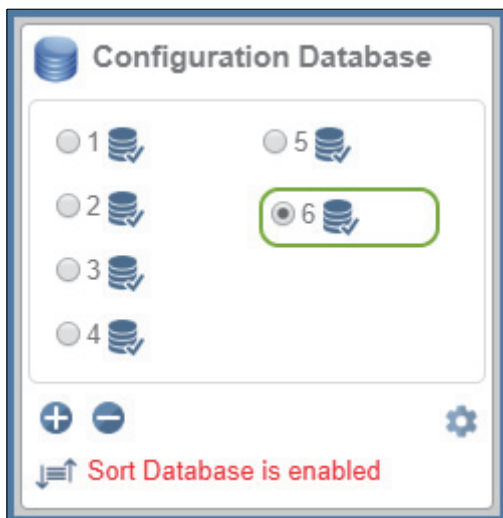



## 4-9 Favorites

The **Favorites** dropdown menu displays commands that you have selected as favorites by clicking the star icons next to command names in the **Advanced Settings** menus. This is useful because it allows you to change the parameters of frequently-used commands without returning to the Advanced Settings menus.

In the example below, notice that the star icon next to the **Light Source** command in the **Camera Setup** menu is selected. This causes that command to appear in the Favorites editor in the **left panel** of WebLink's **Setup** view. Commands that are displayed in Favorites can be configured in the same way as commands in Advanced Settings.

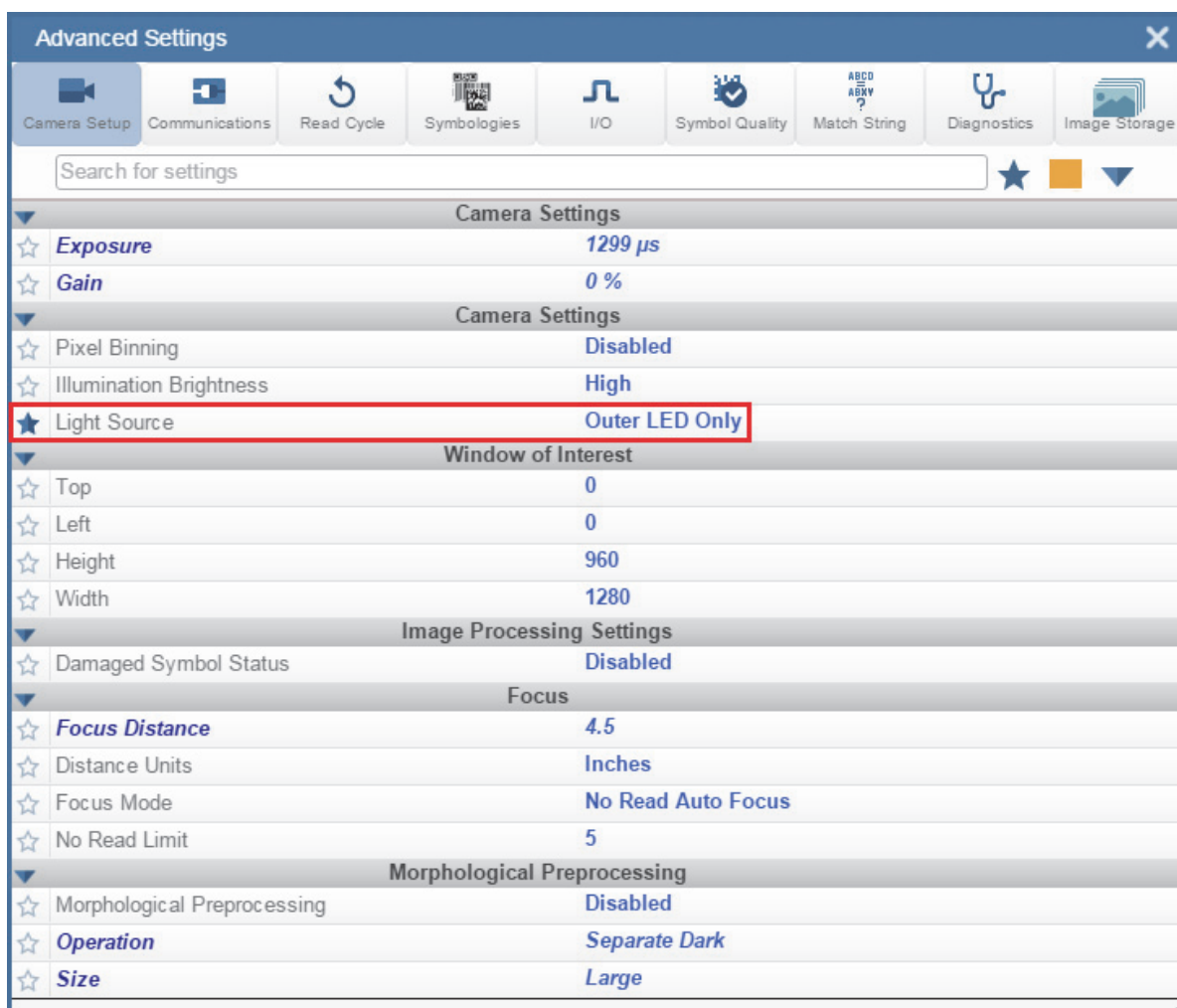
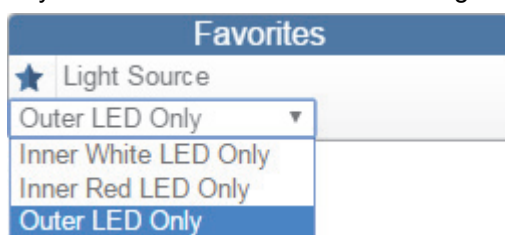



# 5

## Run

In the **Run** view, you can observe the progress of the setup as it follows the parameters you have defined. The **right panel** of the **WebLink** UI shows **Counts** for **Cycles**, **Reads**, **No Reads**, and **Mismatches**, as well as **Rate** information for **Capture**, **Decode**, **Overhead**, **Total Read**, and **Trigger Rate**, as well as **Output Data**. A "filmstrip" below the **Image Area** shows each image capture with a **green check mark** for a good read and a **red x** for a No Read.

---

5-1	Counts.....	5-2
5-2	Rate .....	5-3
5-3	Read Time.....	5-4
5-4	Output Data.....	5-5
5-5	Image History .....	5-6

## 5-1 Counts

---

The **Counts** area of the **right panel** provides five data points:

- **Cycles** shows the total number of captures that have occurred.
- **Reads** shows how many decode attempts have been successful.
- **No Read** shows how many decode attempts have been unsuccessful.
- **Mismatch** shows how many times decoded symbol data has not matched a user-defined character string (if a **Match String** is defined).
- **Read %** shows the percentage of decode attempts that have been successful.

Counts 	
Cycles	174
Reads	174
No Read	0
Mismatch	0
Read %	100.00

You can reset all counts by clicking the **eraser icon**.

## 5-2 Rate

The **Rate** area of the **right panel** provides five data points:

- **Capture** shows the average image capture rate per second.
- **Decode** shows the average decode rate per second.
- **Overhead** shows the average of excess processing time required to achieve captures and decodes.
- **Total Read** shows the total average time required for image capture, decoding, and overhead per second.
- **Trig Rate** shows the average number of triggers per second.

Rate 		
Capture	244.6 ms	4.1/s
Decode	405.1 ms	2.5/s
Overhead	1.0 ms	
Total Read	650.6 ms	1.5/s
Trig Rate	1688.0 ms	0.59/s

You can reset all rate data by clicking the **eraser icon**.

## 5-3 Read Time

---

**Read Time (ms)** is a real-time line graph representation of the read time data point in the **Rate** area of the right panel.

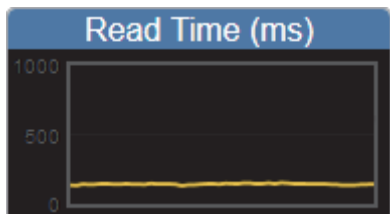

## 5-4 Output Data

---

The **Output Data** area of the **right panel** shows the data from each symbol decoded in a read cycle. The preamble and postamble are also shown here if enabled and configured.

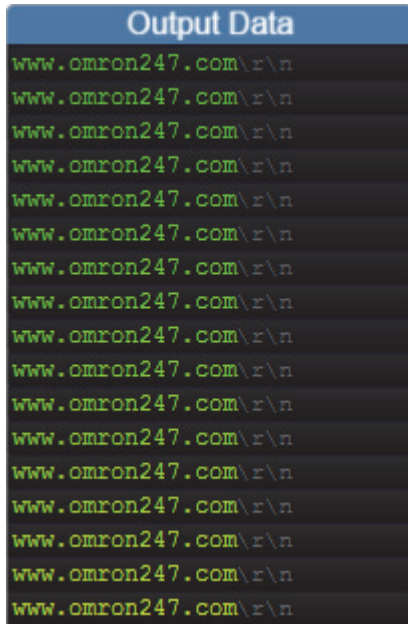

The screenshot shows a panel titled "Output Data" with a dark background and light text. It displays a list of 15 entries, each consisting of the text "www.omron247.com\r\n" followed by a carriage return and a line feed character. The text is displayed in a monospaced font.

```
www.omron247.com\r\n  
www.omron247.com\r\n  
www.omron247.com\r\n  
www.omron247.com\r\n  
www.omron247.com\r\n  
www.omron247.com\r\n  
www.omron247.com\r\n  
www.omron247.com\r\n  
www.omron247.com\r\n  
www.omron247.com\r\n  
www.omron247.com\r\n  
www.omron247.com\r\n  
www.omron247.com\r\n  
www.omron247.com\r\n
```

## 5-5 Image History

---

**Image History** is a series of thumbnail representations of each image capture. The Image History appears below the **Image Area** in the **Run** view. Each image capture thumbnail shows a **green check mark** for a good read and a **red x** for a no read.

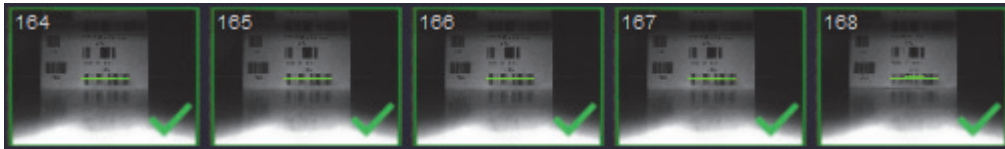





# Application Settings

This section describes the **Application Settings** menu, which enables you to control a wide array of **WebLink** and **MicroHAWK** functions.

---

6-1	Application Settings Menu .....	6-2
6-2	Save.....	6-3
6-3	New .....	6-4
6-4	Load .....	6-5
6-5	Advanced .....	6-6
6-6	Language .....	6-7
6-7	Terminal .....	6-8
6-8	Beeper.....	6-9
6-9	Guided Tour .....	6-10
6-10	Image Storage .....	6-11
6-11	Restore Default Settings .....	6-18
6-12	Activate Account Management.....	6-19
6-13	Enable USB Drive Mode .....	6-27
6-14	About WebLink .....	6-28

## 6-1 Application Settings Menu

---

Click the **gear icon** to the right of the **help icon** to open the **Application Settings** menu.



The **Application Settings** menu includes several functions: **Save**, **New**, **Load**, **Advanced**, **Language**, **Terminal**, **Beeper**, **Guided Tour**, **Image Storage**, **Restore Default Settings**, **Active Account Management**, **Enable USB Drive Mode\***, and **About WebLink**.

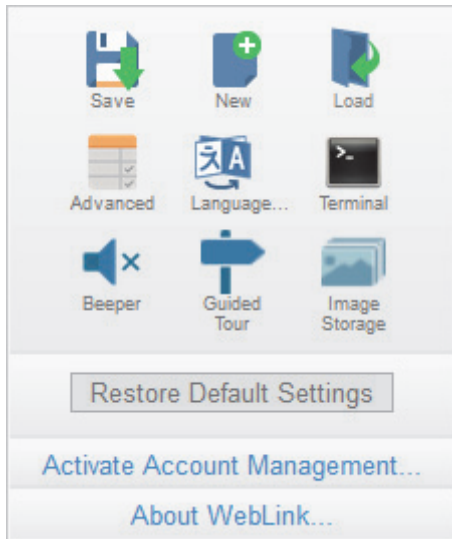

**\*Note:** The **Enable USB Drive Mode** option only appears when you are using a MicroHAWK V420-F, which supports USB connectivity.

## 6-2 Save

---

**Save** saves the current configuration.

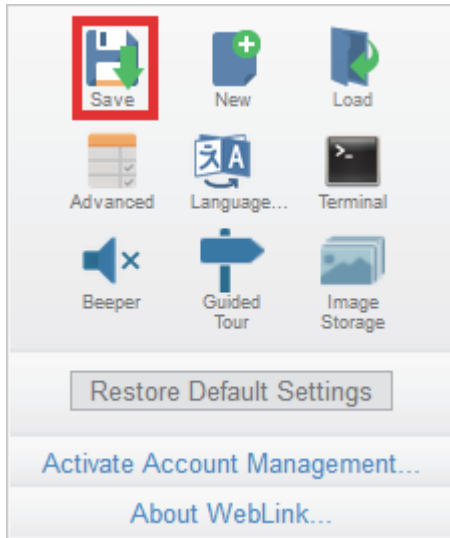

## 6-3 New

---

**New** opens a new WebLink session.

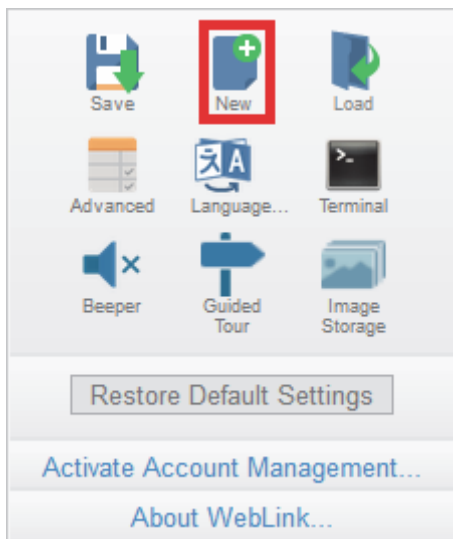

## 6-4 Load

---

**Load** allows you to open an existing configuration.

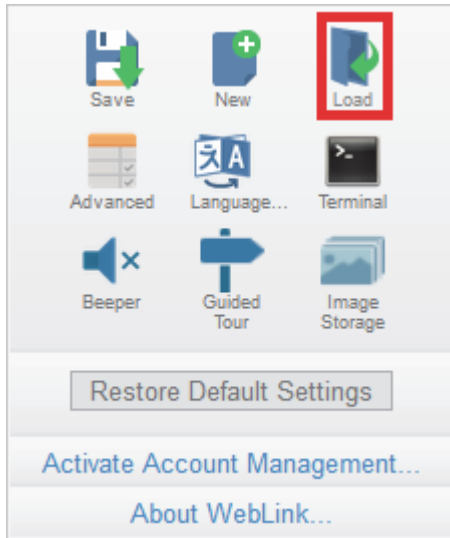

## 6-5 Advanced

---

**Advanced** allows you to make precise adjustments to every area of reader functionality: **Camera Setup**, **Communications**, **Read Cycle**, **Symbologies**, **I/O**, **Symbol Quality**, **Match String**, **Diagnostics**, **Image Storage**, and **Configuration Database**.

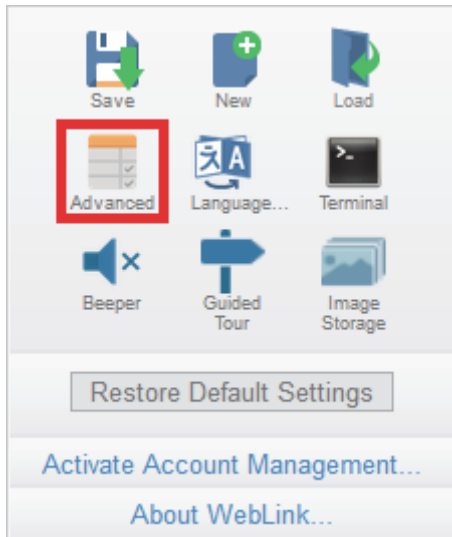

## 6-6 Language

**Language** allows you to choose the language in which you prefer to use the WebLink interface.

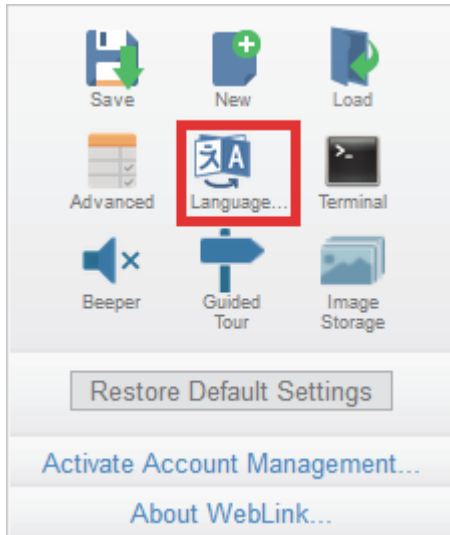

**Important:** The reader will restart when a different language is selected.

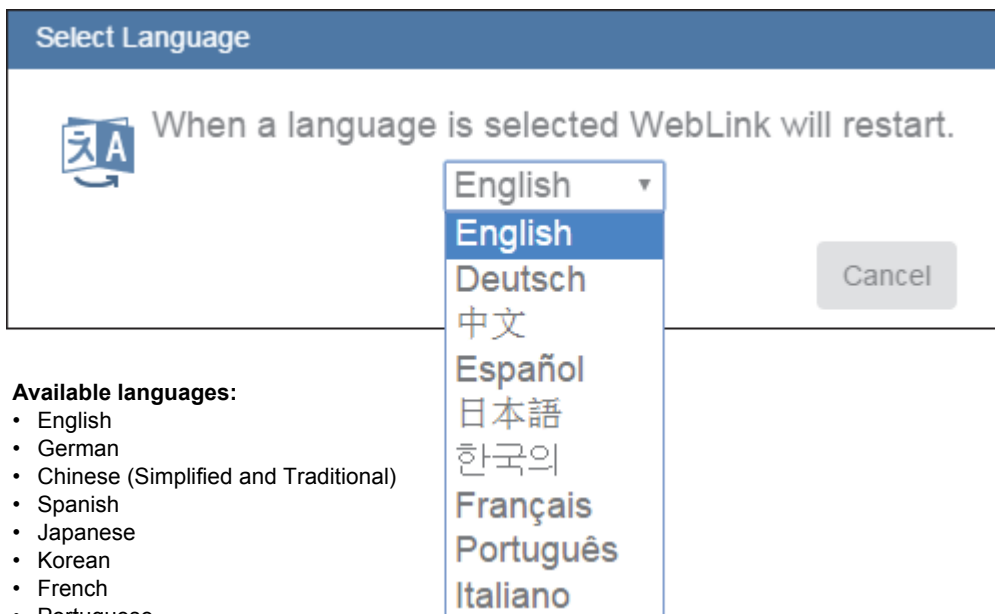

**Available languages:**

- English
- German
- Chinese (Simplified and Traditional)
- Spanish
- Japanese
- Korean
- French
- Portuguese
- Italian

## 6-7 Terminal

---

**Terminal** opens WebLink's Terminal interface, where serial commands can be sent, responses from the reader can be shown, and reader output can be displayed.

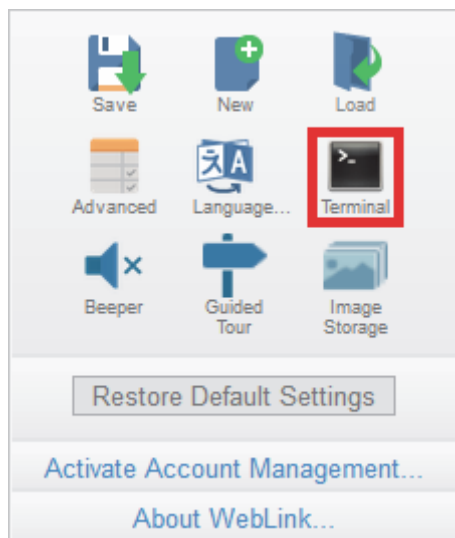



## 6-8 Beeper

---

Enabling **Beeper** causes your PC to beep when WebLink receives a decode from the reader.

**Note:** There is no beeper in MicroHAWK reader hardware.

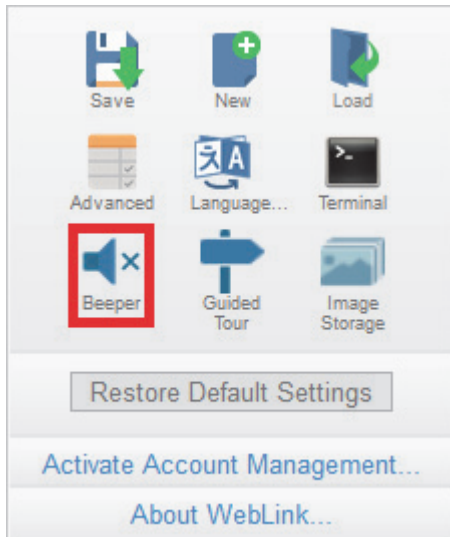

## 6-9 Guided Tour

---

Clicking **Guided Tour** launches a tutorial that explains the functions of the various areas of the WebLink user interface.

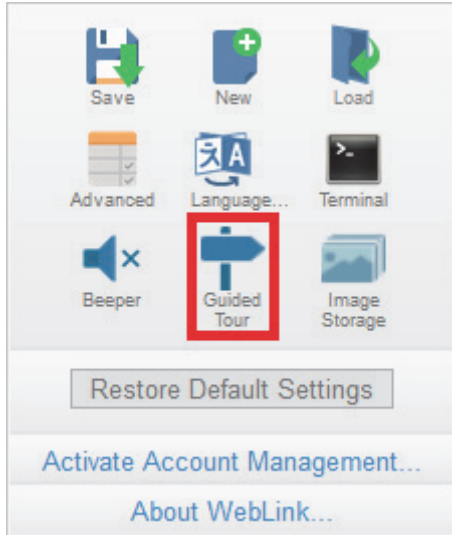

## 6-10 Image Storage

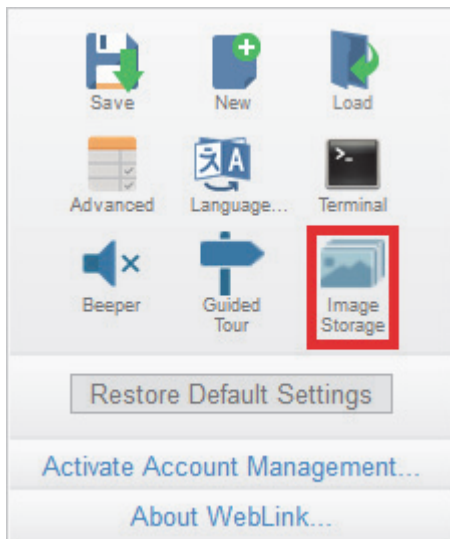

When you click the **Image Storage** icon in the **Application Settings** menu, you will see this dialog:

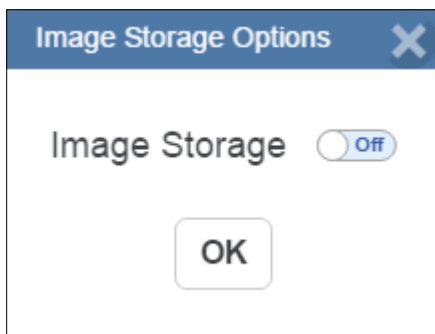

When you turn Image Storage **on** and click **OK**, the dialog will expand as shown below. The **Image Storage Options** dialog shows commands that allow you to control how, when, and where images captured by the camera are stored.

The screenshot shows the 'Image Storage Options' dialog box. At the top, the title bar reads 'Image Storage Options' with a close button (X) on the right. Below the title bar, the 'Image Storage' toggle switch is turned 'On'. The settings are as follows:

- Stored Image Type: **No Read**
- Storage Mode: **First image in a read cycle**
- Image File Format: **PNG - High Resolution**
- Image Quality: **90 %**
- Image Scale: **Full scale**
- File Save Options: **Image**
- Image Storage Location: **RAM (Volatile Memory)**
- RAM Drive Size: **20 MB** *Up to 17 images*
- Save Image Until: **New Read Cycle**
- Action at Image Storage Limit: **Stop**

At the bottom of the dialog, there are two buttons: 'OK' and 'Default'.

If **Image Storage Location** is set to **Remote (FTP)**, the **FTP Address** will appear, allowing you to input the user ID, password, and address of the applicable FTP server.

The screenshot shows the 'Image Storage Options' dialog box with 'Remote (FTP)' selected in the 'Image Storage Location' dropdown menu. The settings are as follows:

- Image Storage: **On**
- Stored Image Type: **No Read**
- Storage Mode: **First image in a read cycle**
- Image File Format: **PNG - High Resolution**
- Image Quality: **90 %**
- Image Scale: **Full scale**
- File Save Options: **Image**
- Image Storage Location: **Remote (FTP)**
- FTP Address: **userid:pass@xxx.xxx.xxx.xxx**
- Transfer Optimization: **Speed**
- Transfer Buffer Size: **20 MB** *Up to 17 images per read cycle*

At the bottom of the dialog, there are two buttons: 'OK' and 'Default'.

If the RAM drive size changes, the message shown below will appear in the **Image Storage Location** dialog.

If you click **Revert**, the RAM drive size returns to its previous size.

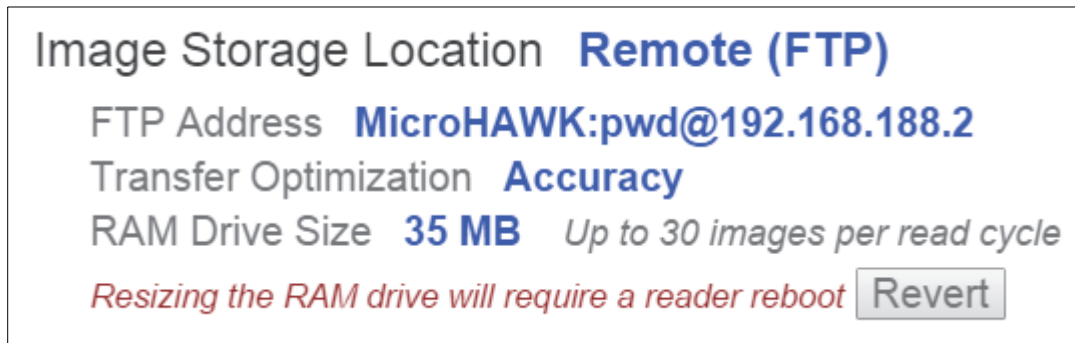

All **Image Storage** settings can also be configured in **Advanced Settings**.

### 6-10-1 Image Storage by External FTP Server

An external FTP server can be used to store images captured by the MicroHAWK. The reader can connect to an FTP server and can send images and cycle reports to that server for storage. The following procedure describes how to set up an external FTP server.

The example procedure shown here uses **FileZilla Server**, which can be downloaded at <https://filezilla-project.org/>. Note that FileZilla is a Windows-only utility.

- Download and install FileZilla Server.

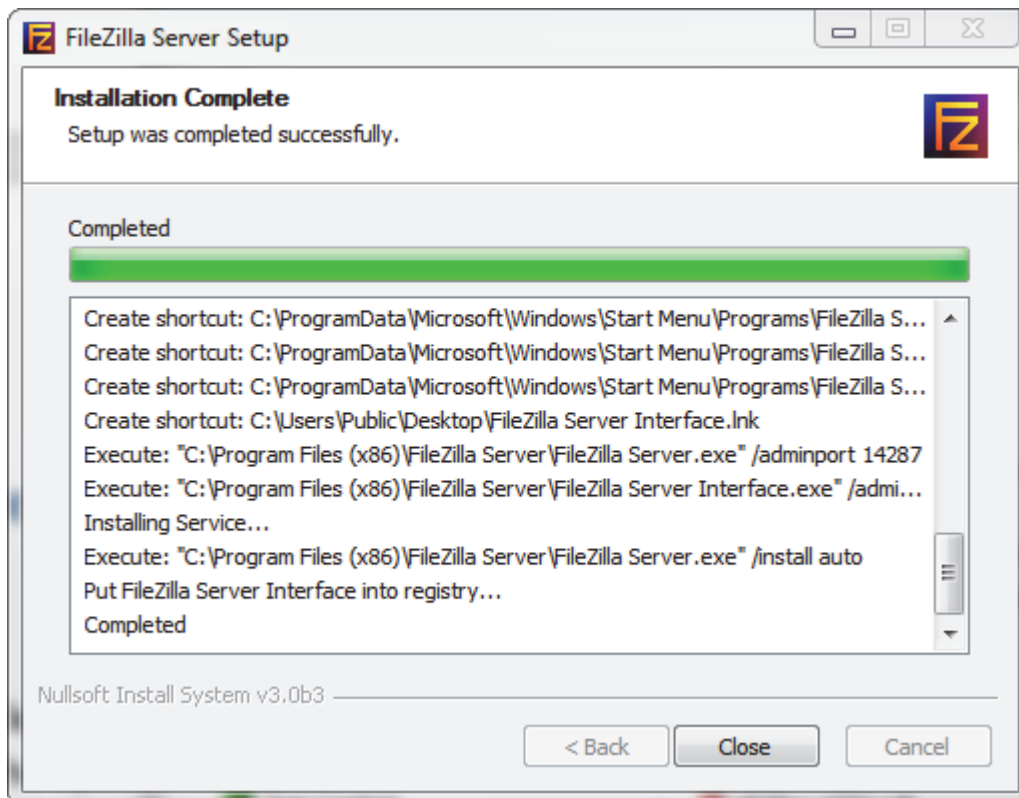

- Connect to the server. Use the **127.0.0.1** server address if you are setting up the server on your PC. Note the port that you use – **14147** in the example shown here – as the port number will be required when you log back into the server.

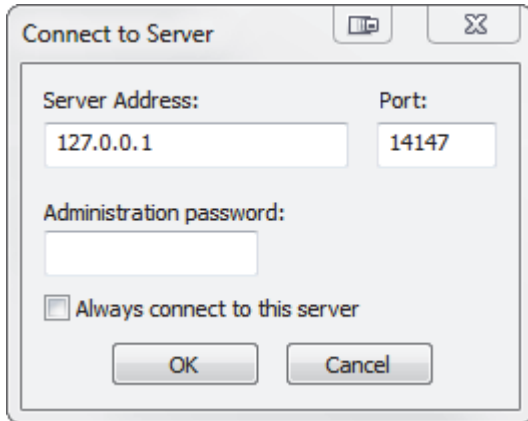

- Configure the settings on the **General** page of the **Users** dialog.

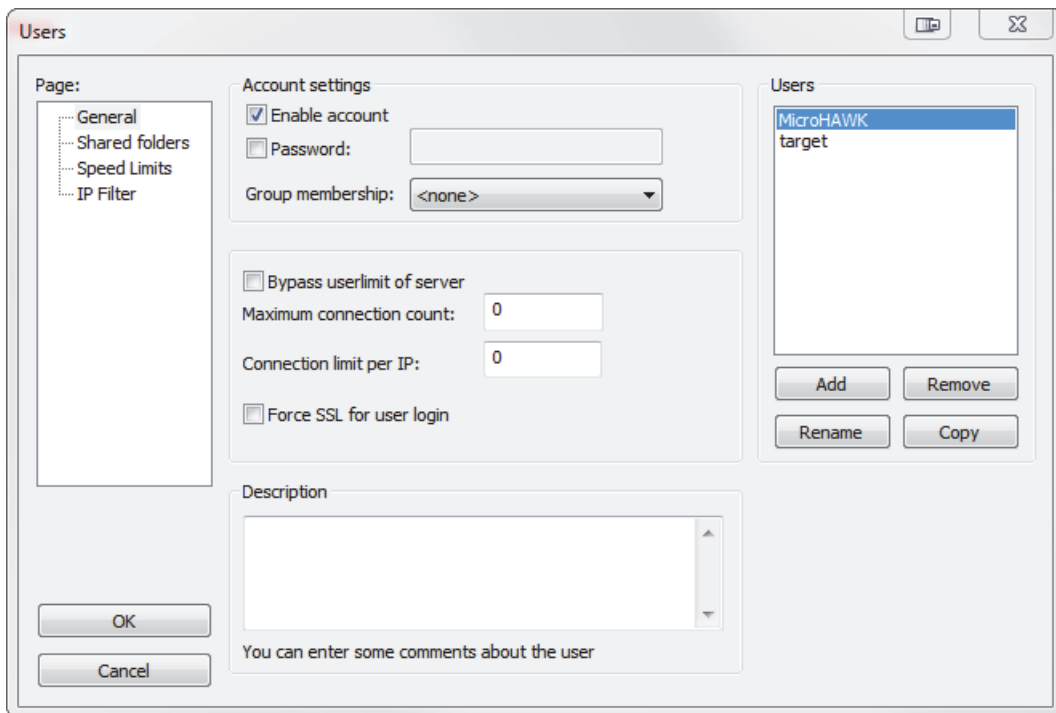

- Navigate to **Shared folders** under **Page:** in the left panel. Be sure that **Write** (under **Files**) is checked and that **Create** (under **Directories**) is checked. Add a new user group – **MicroHAWK** in this example.

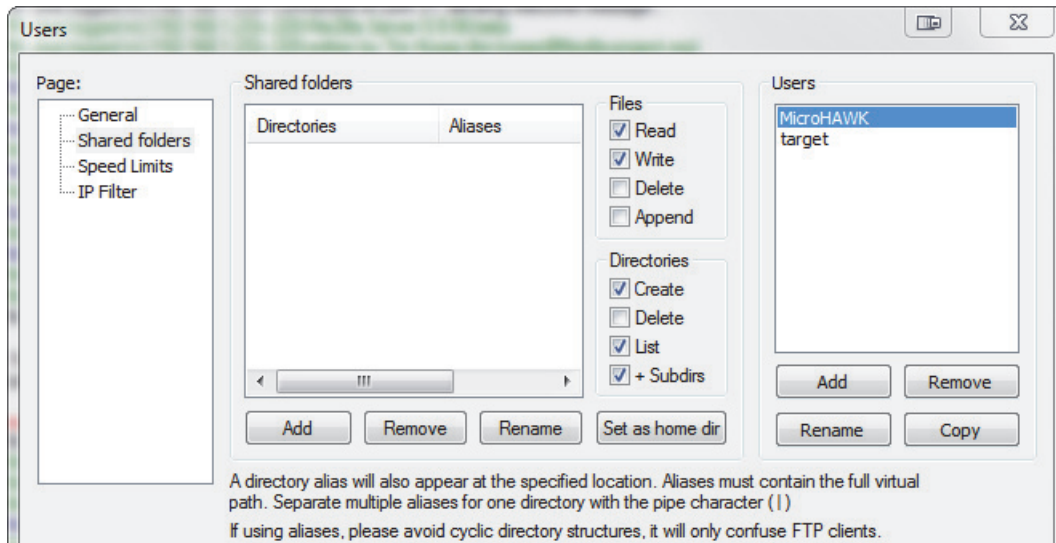

- Browse for the folder on your PC where you want to store images. In this example, the folder is called **C:\Users\el\Desktop\MicroHAWK images**.

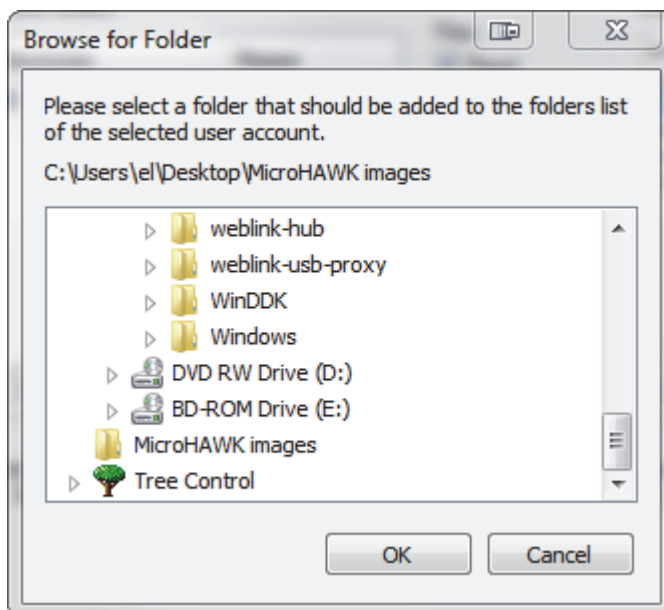

- Return to the **General** page and set a password.

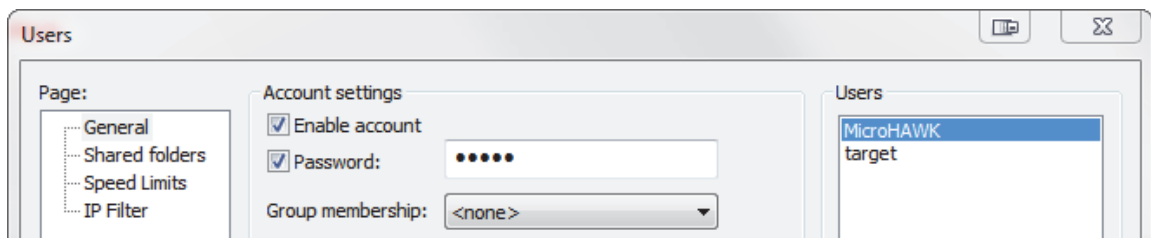

- Click **OK** and connect to your MicroHAWK ID reader.

- Open **Application Settings** and click the **Image Storage** icon.

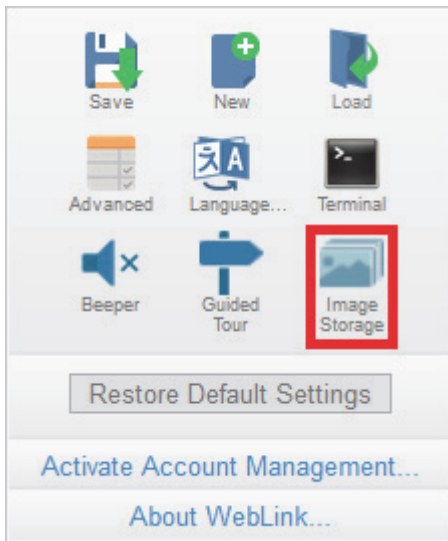

- Update your **Image Storage Options**, including your FTP Address.

**Note:** **pwd** represents the password you set on the **General** page of the FileZilla Server interface.

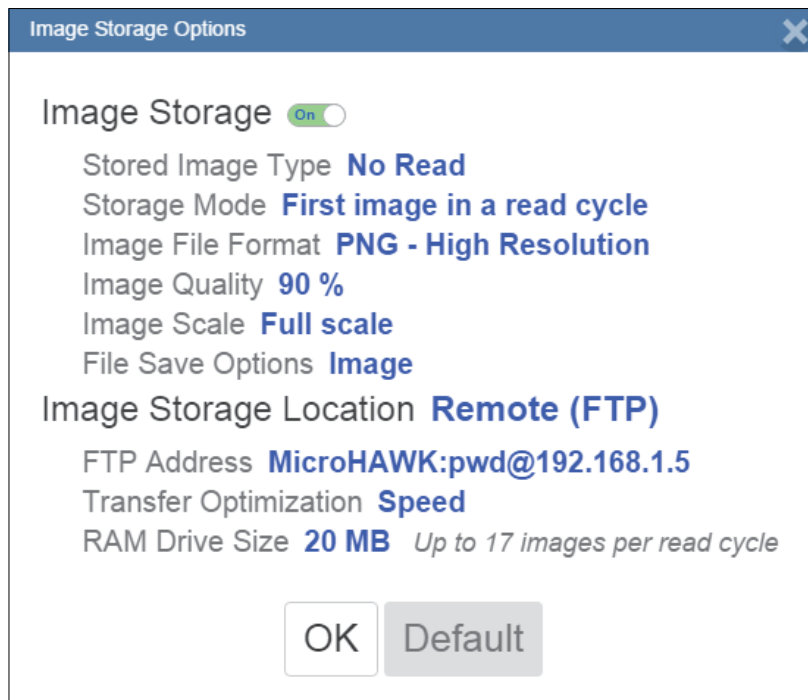



## 6-10-2 Start and Stop FileZilla Server

During FileZilla installation, you have the option of configuring FileZilla Server to auto-start each time the MicroHAWK is powered on. You can also start and stop the server manually via the **Start FileZilla Server** and **Stop FileZilla Server** shortcuts shown here.



To disable FileZilla Server's auto-start feature:

- Type the **Windows button + the 'R' key** to bring up the **Run** dialog.
- In the Run dialog's **Open:** field, type **msconfig** and then **Enter**.
- Click the **Startup** tab as shown below.
- Uncheck **FileZilla Server** so it won't launch on startup.

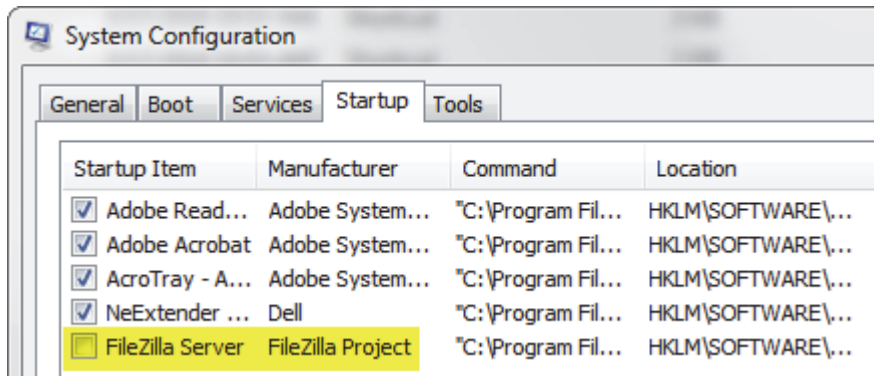

- Click **OK**.
- When prompted, **restart** your computer.

## 6-11 Restore Default Settings

---

**Restore Default Settings** returns the reader to the default state in which it was shipped from the manufacturer.

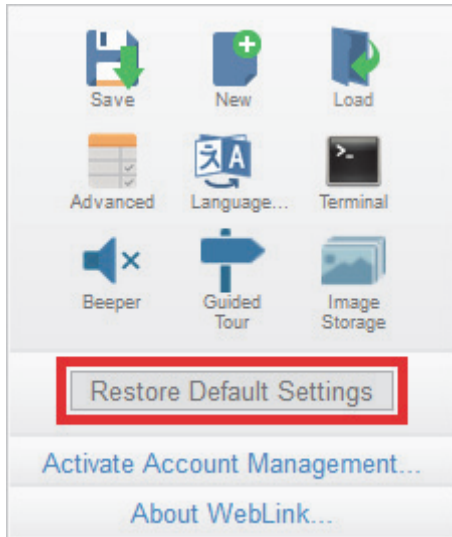

## 6-12 Activate Account Management

**Activate Account Management** allows you to set a password that will be required to open any session of WebLink. An Administrator can create, update, and delete users from an Administrator user interface. While management is active, every user must log in with a username and password established by the Administrator to use WebLink. There are three different user types, each with a different privilege level that determines their access:

- **Administrator** (Full Access as well as the ability to manage user accounts and enable or disable Account Management)
- **Controller** (Full Access)
- **Monitor** (View-Only Access)

Click the gear icon at the upper right of the WebLink user interface to open the **Application Settings** menu.

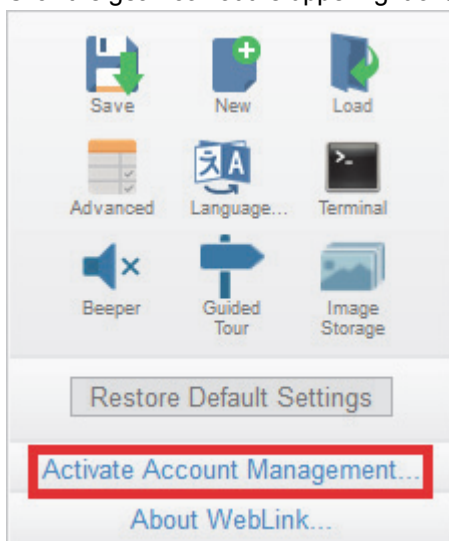

Then click **Activate Account Management** to open the dialog shown below.

Enter and verify a new username and password and then click **Activate Account Management** to password-protect the WebLink configuration.

The Activate Account Management button brings up a dialog allowing you to create an Administrator account and to Activate Account Management. This is the same account information that you will use to log in to the application later, so be sure to remember it. After entering valid credentials, click the blue **Activate Account Management** button. Clicking this button will create the Administrator account and will restart the application.

Activate Account Management

Activating account management will restart the application and require login ?

JillBecker

.....

.....

Cancel Activate Account Management

**Note:** When **Account Management** is active, **Activate Account Management** will not appear in the Application Settings menu.

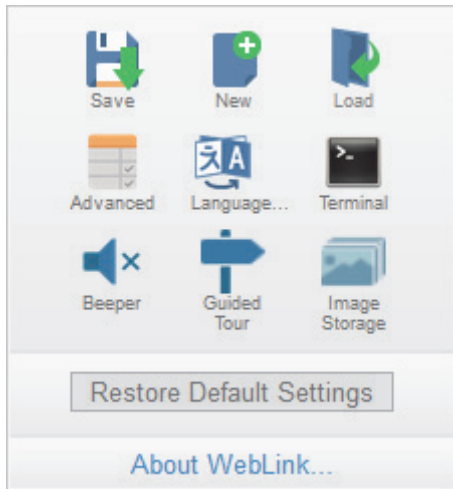

After you've clicked **Activate Account Management**, the WebLink application will be refreshed and you will see the login screen shown below. Since you haven't created other users yet, you must enter your own newly-created Administrator credentials.

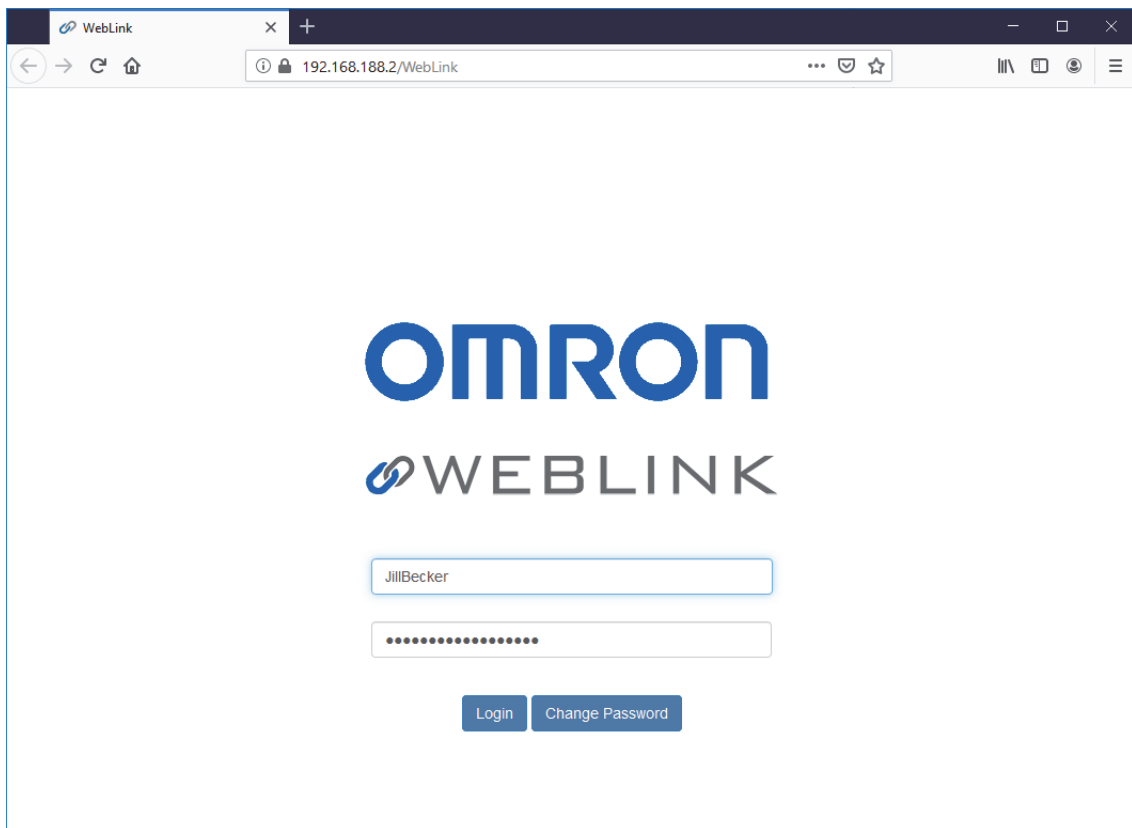

## 6-12-1 Admin View

After successfully logging in, you will see an **Admin** tab to the right of the **Start**, **Setup**, and **Run** tabs. Click the **Admin** tab to view the **Account Management** interface. This interface is only visible to the Administrator.

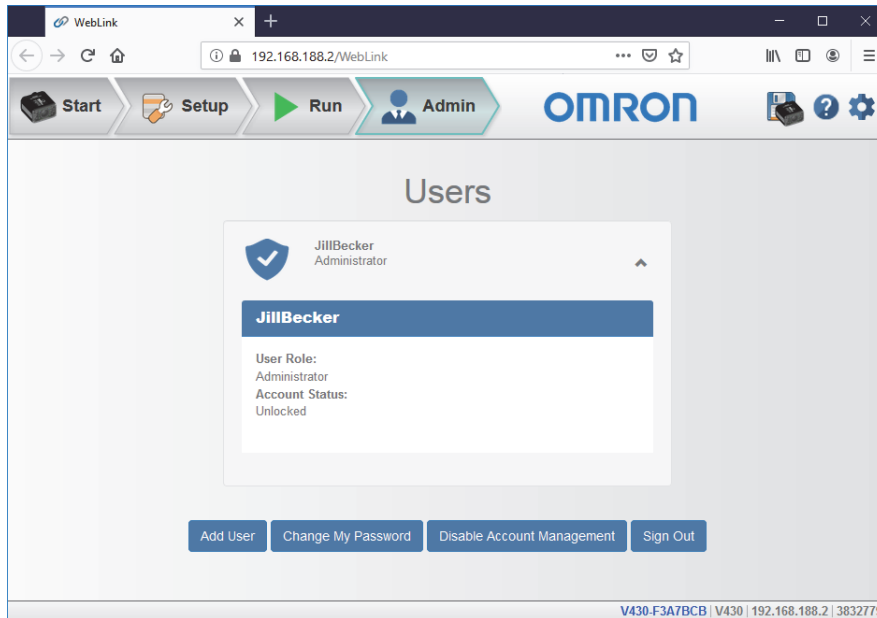

There are four primary buttons in the **Admin** view:

- **Add User:** Create a new user by establishing a username, password, and account type.
- **Change My Password:** Change Administrator password.
- **Disable Account Management:** Turn off Account Management with the option to reactivate it with existing users, or to turn off account management and delete all current users (including Administrator).
- **Sign Out:** Sign out of this account and return to the login screen.

When multiple user accounts have been created, all users are shown in the list above the four primary buttons. Initially only the Administrator will be shown, but the list will grow as you create more users. Each user tab can be expanded by clicking on the chevron icon on the far right. Before expanding, notice the basic layout of the user panel. It contains user information on account type, username, and an icon that represents the account type.

## 6-12-2 Managing User Accounts

When you select **Add User**, you will see the **Create New User** dialog, which allows you to set the username, password, and account type (**Controller** or **Monitor**).

You can create users of either account type.

The screenshot shows a 'Create New User' form with the following elements:

- Username field: TedBaker
- Password field: [Redacted]
- Confirm Password field: [Redacted]
- Account Type dropdown: Opened, showing 'Controller' and 'Monitor' (selected).
- Buttons: 'Cancel' and 'Create'.

Each time you add a user, that user's information is added to the **Admin** view, as shown below.

The screenshot shows the 'Admin' view of the WebLink interface. The 'Users' section displays a list of users:

User Name	Role	Action
JillBecker	Administrator	▼
JaneTanaka	Controller	▼
TedBaker	Monitor	▼

At the bottom of the 'Users' section, there are four buttons: 'Add User', 'Change My Password', 'Disable Account Management', and 'Sign Out'.

Clicking on the down arrow to the right of each user opens a view similar to the one shown below. This view allows you to update the **User Role** and **Account Status**.

You can also delete a user from this view.

In the example shown here, the Administrator has changed the user's account from **Unlocked** to **Locked**.

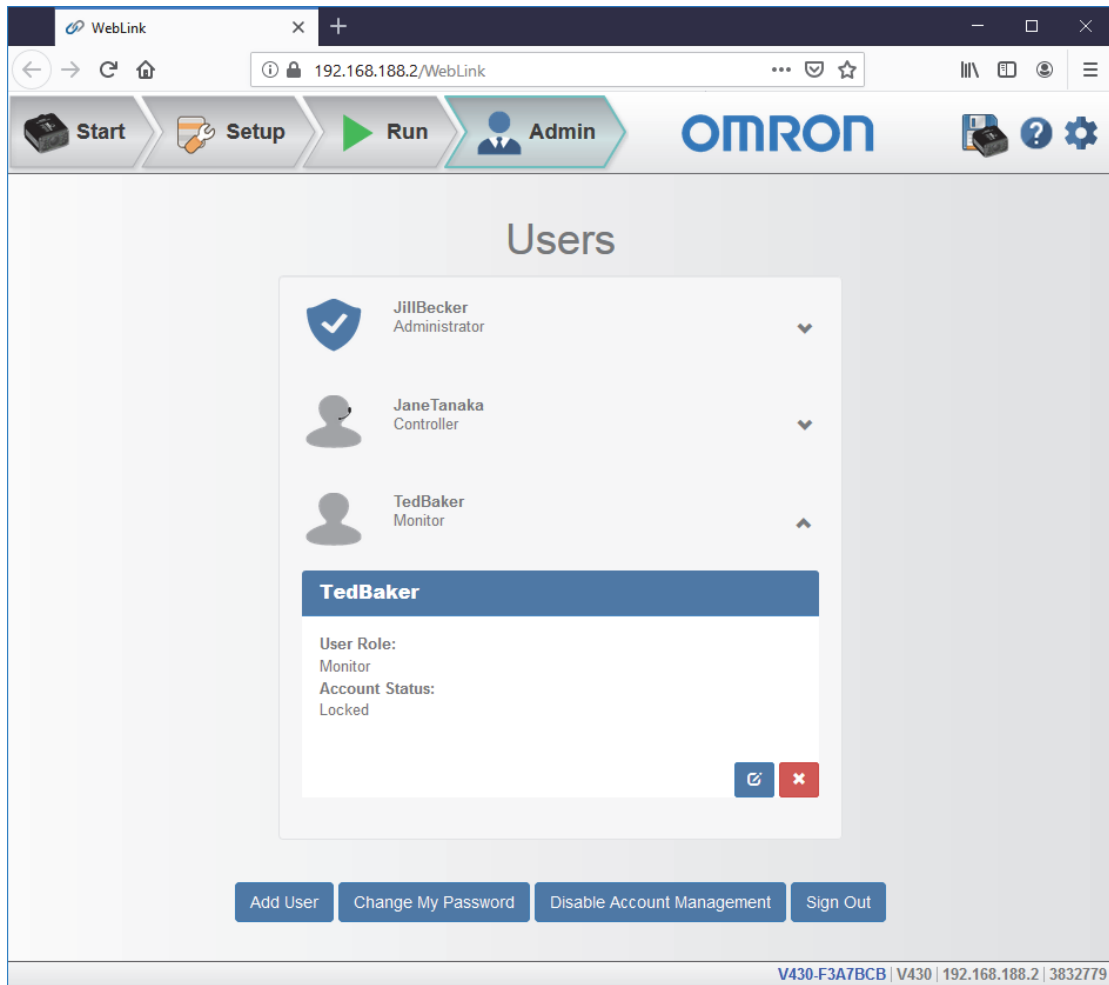

6

When a user's account is locked, a lock icon will appear to the right of the user's name.

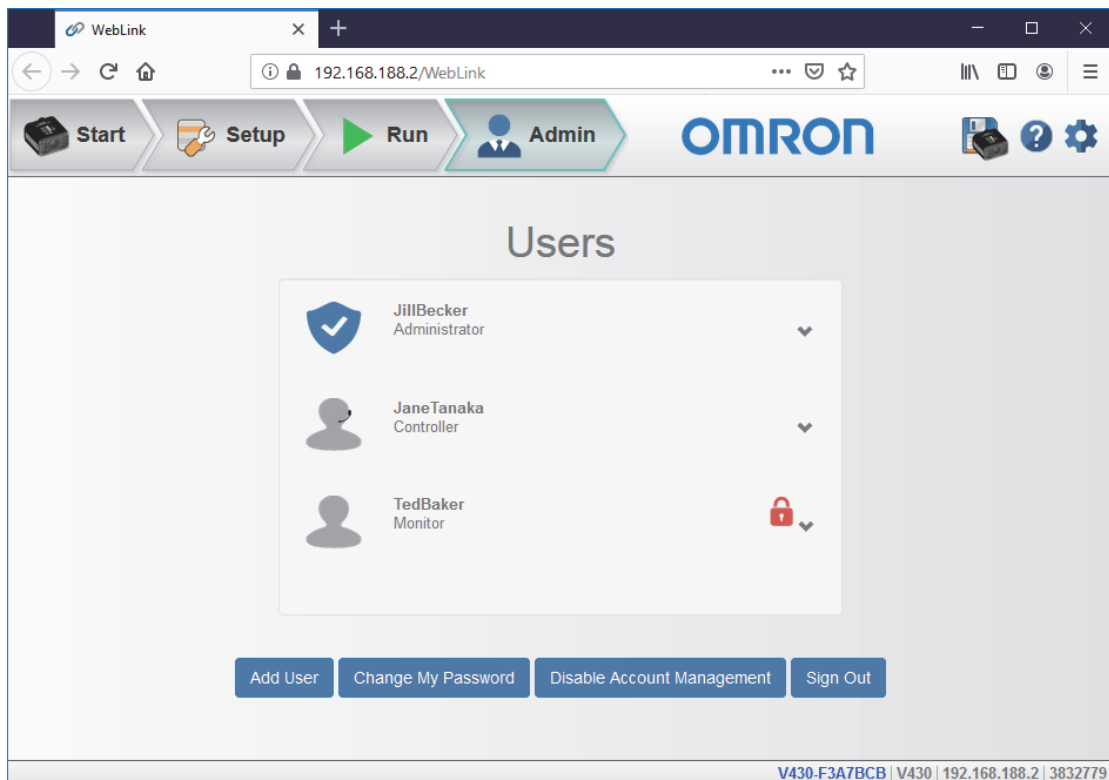

Two buttons appear in the lower right of each user profile when it is expanded. These buttons allow the Administrator to make changes to user accounts.

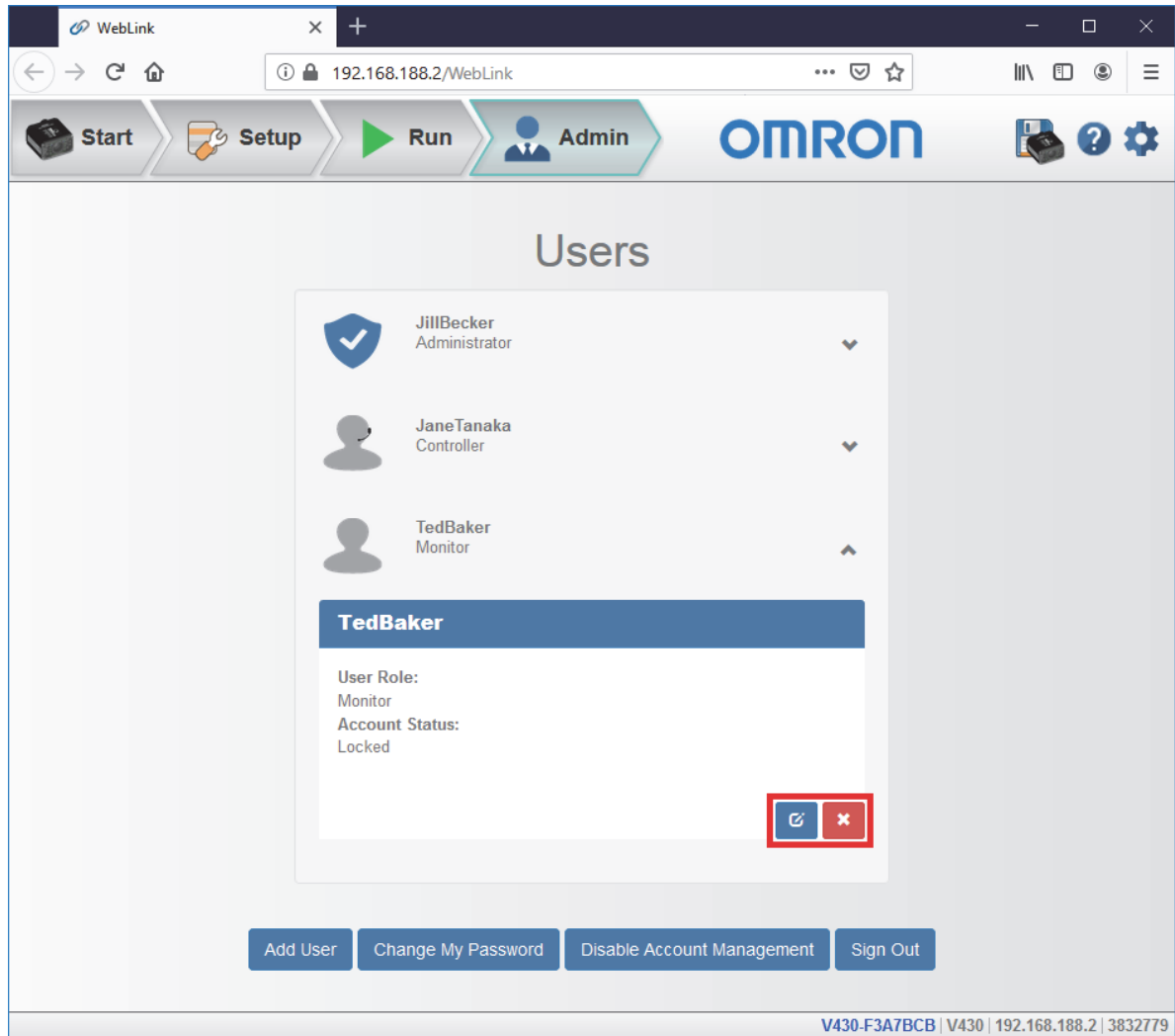

The blue button allows the Administrator to modify user information, such as password, account type, or account status.



The red button allows the Administrator to delete the user.





### 6-12-3 Account Status

There are four types of User Account Status: **Unlocked**, **Locked**, **Wait**, and **Continue**. Each status is described below.

#### Account Status Information

Status	Description
<b>Unlocked</b>	User can access WebLink by logging in with their username and password.
<b>Locked</b>	User failed multiple login attempts and must have their account unlocked by the administrator to access WebLink.
<b>Wait</b>	User is temporarily locked out of WebLink for repeatedly providing an invalid password.
<b>Continue</b>	User can access WebLink by logging in with their username and password, but will be Locked if they repeatedly provide an invalid password.

OK

### 6-12-4 Changing Your Password

Clicking **Change My Password** causes the following dialog to appear, allowing you to enter and verify a new password of your choice.

#### Update Password

.....

.....

.....

Cancel

Update

## 6-12-5 Disabling Account Management

If you are the Administrator, you can either **Disable** Account Management and retain your account information and that of the other users, or you can **Disable and Delete Users**, which will erase your account information and that of the other users.

Disable Account Management

**Are you sure you want to disable account management?**

**Disabling account management will restart the application.**

Cancel

Disable

Disable & Delete Users

## 6-13 Enable USB Drive Mode

**Note:** The **Enable USB Drive Mode** option only appears in the **Application Settings** menu when you are using a V420-F, which supports USB connectivity.

Clicking **Enable USB Drive Mode** in the **Application Settings** menu brings up the Enable USB Drive Mode dialog shown below.

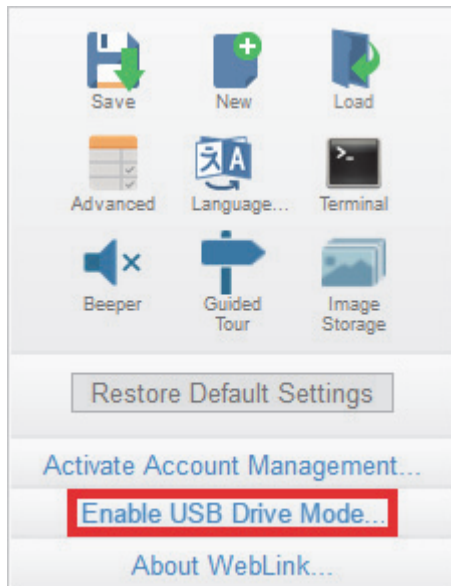

When you click the **Enable** button in the dialog, your reader will reboot, and then you can use it as you would a USB flash drive. If you click **Enable – Don't Reboot**, the camera will reboot later.

**Important:** The USB drive functionality self-disables on the next reader reboot. To enable USB drive functionality again, follow the same procedure described above.

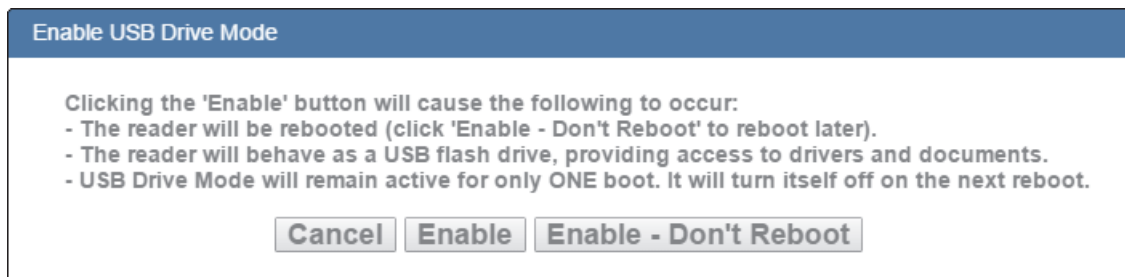

If you try to enable USB Drive Mode when it's already enabled, this dialog will appear:

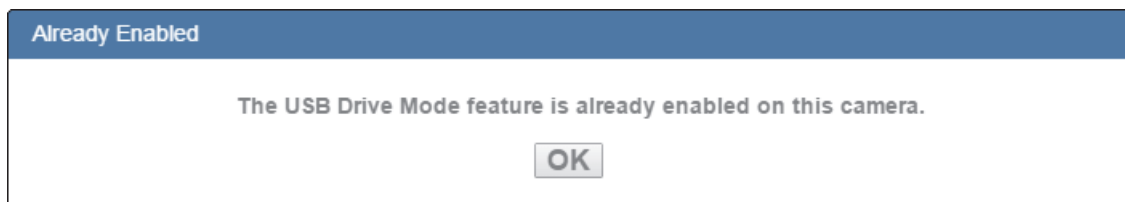

## 6-14 About WebLink

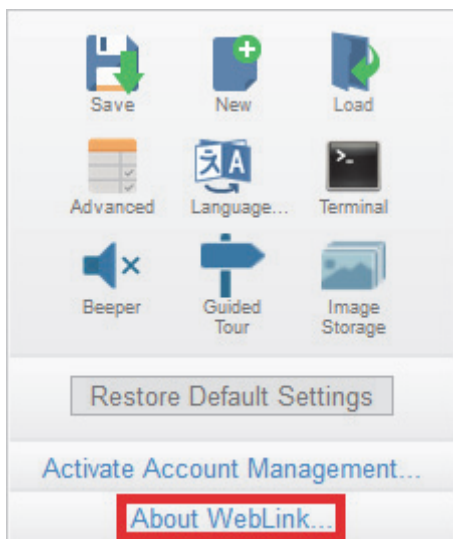

**About WebLink** opens the dialog shown below, which shows the current **WebLink version, Reader Model, Serial Number, Part Number, MAC ID, Sensor, Firmware version, Boot version, Browser, Operating System, and Screen Resolution.**

**Note:** The information in this dialog is selectable so that you can copy it to a clipboard.

Clicking **Contact us...** takes you to the [Omron Automation website](#).





# Terminal

The **Terminal** provides immediate visibility of decode output, allows you to send serial commands to the reader, and allows you to find specific strings within large amounts of data.

---

7-1	Send .....	7-2
7-2	Find .....	7-3
7-3	Filters .....	7-4

## 7-1 Send

---

The Terminal features an auto-complete function that shows several common serial command options as soon as you start typing in the **command to send** field.

The Terminal automatically adds the < and > characters to commands entered in the **command to send** field.

Serial commands sent from the Terminal appear in yellow text and reader output is returned in white text.

Click the **eraser icon** to clear the Terminal screen of all commands, reader responses, and decode output.

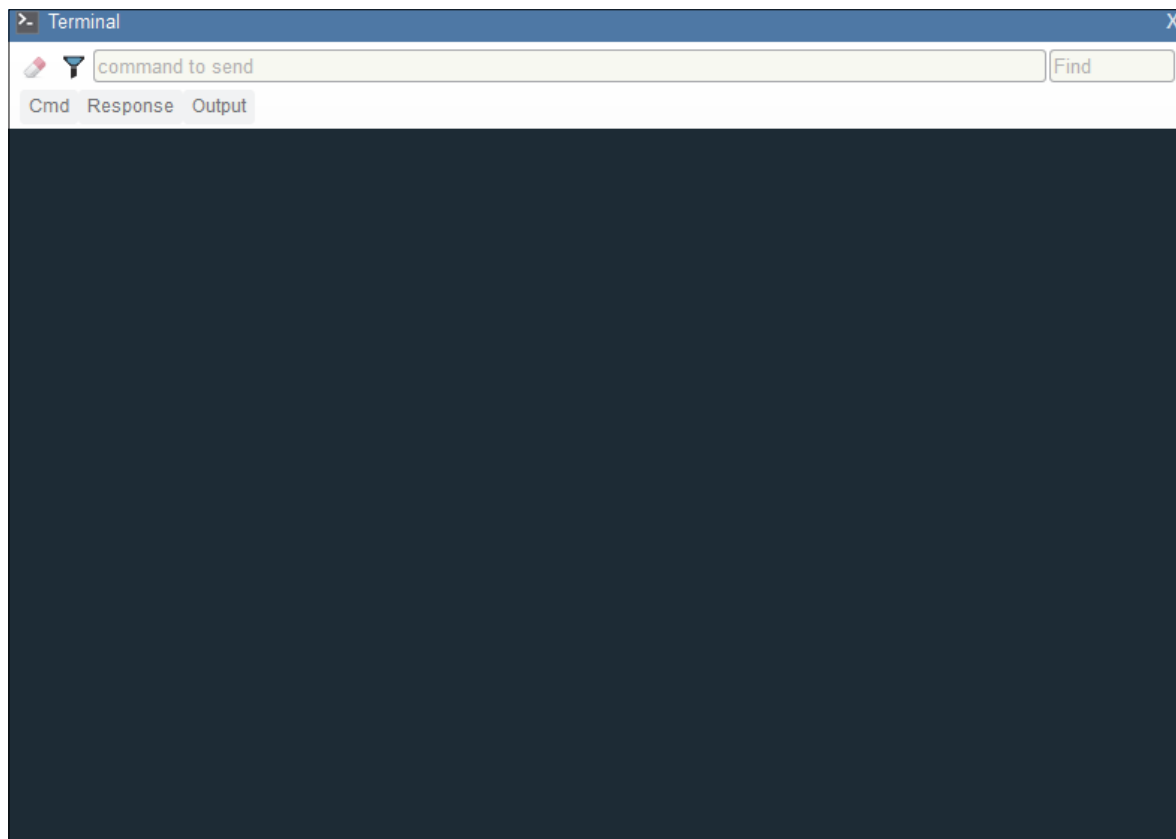

## 7-2 Find

---

The **Find** field in the top right of the window allows you to enter a specific character string to locate within the data on the Terminal screen.

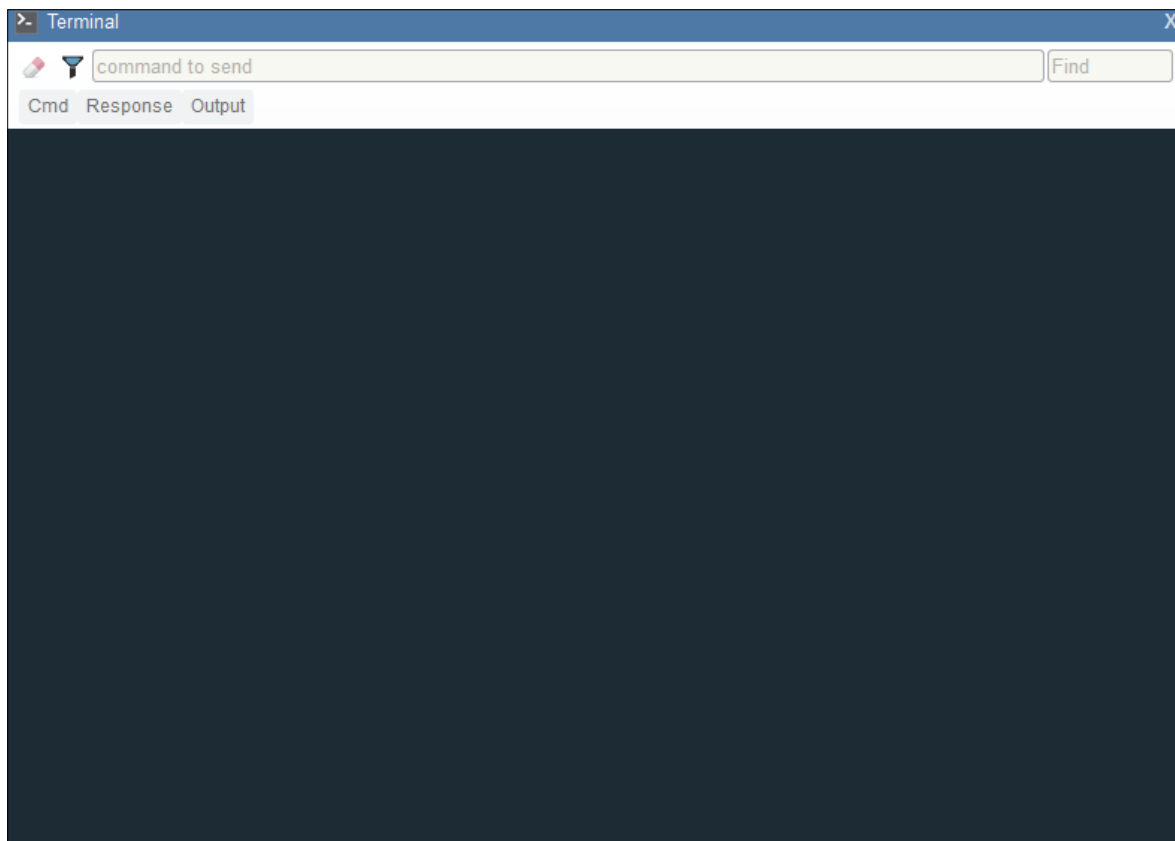

## 7-3 Filters

Click the **filter icon** to the right of the erase icon to display the three filter buttons.

### 7-3-1 Cmd

When the **Cmd** filter button is selected, serial commands sent from the Terminal are shown. When only the Cmd button is selected, only serial commands are shown.

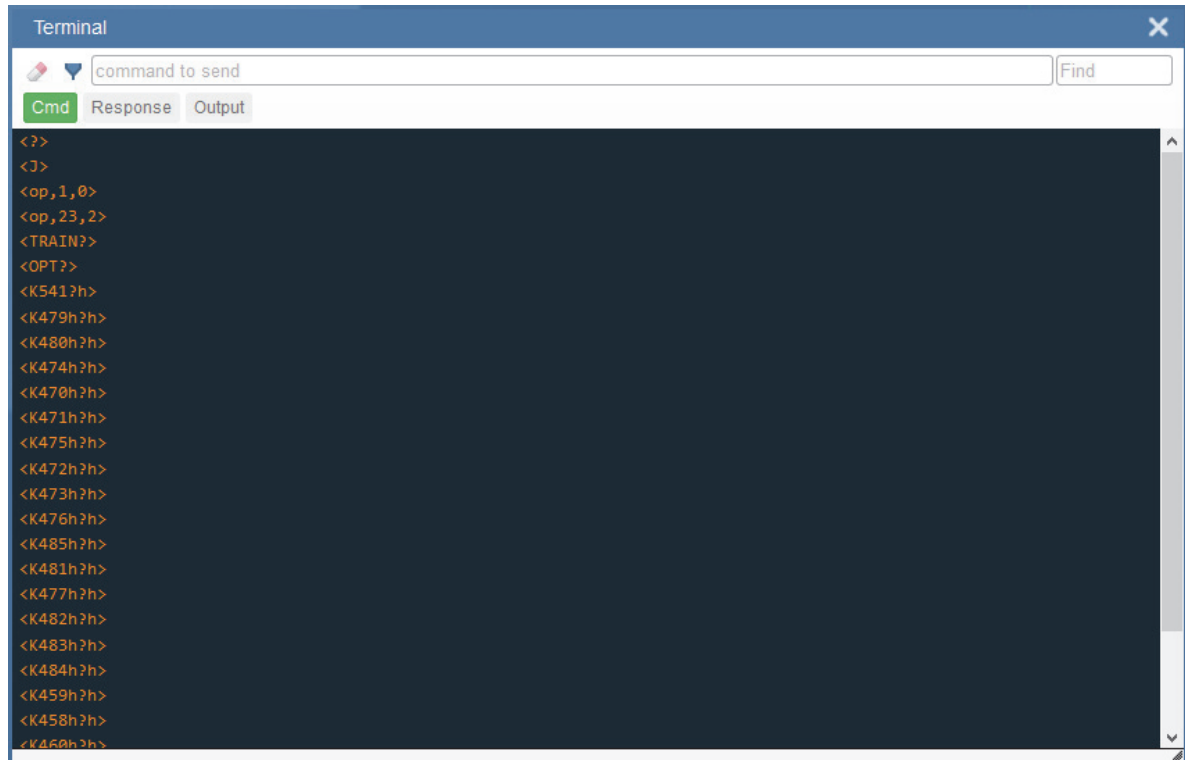



## 7-3-2 Response

When the **Response** filter button is selected, responses sent back from the reader are shown. When only the Response button is selected, only responses sent back from the reader are shown.

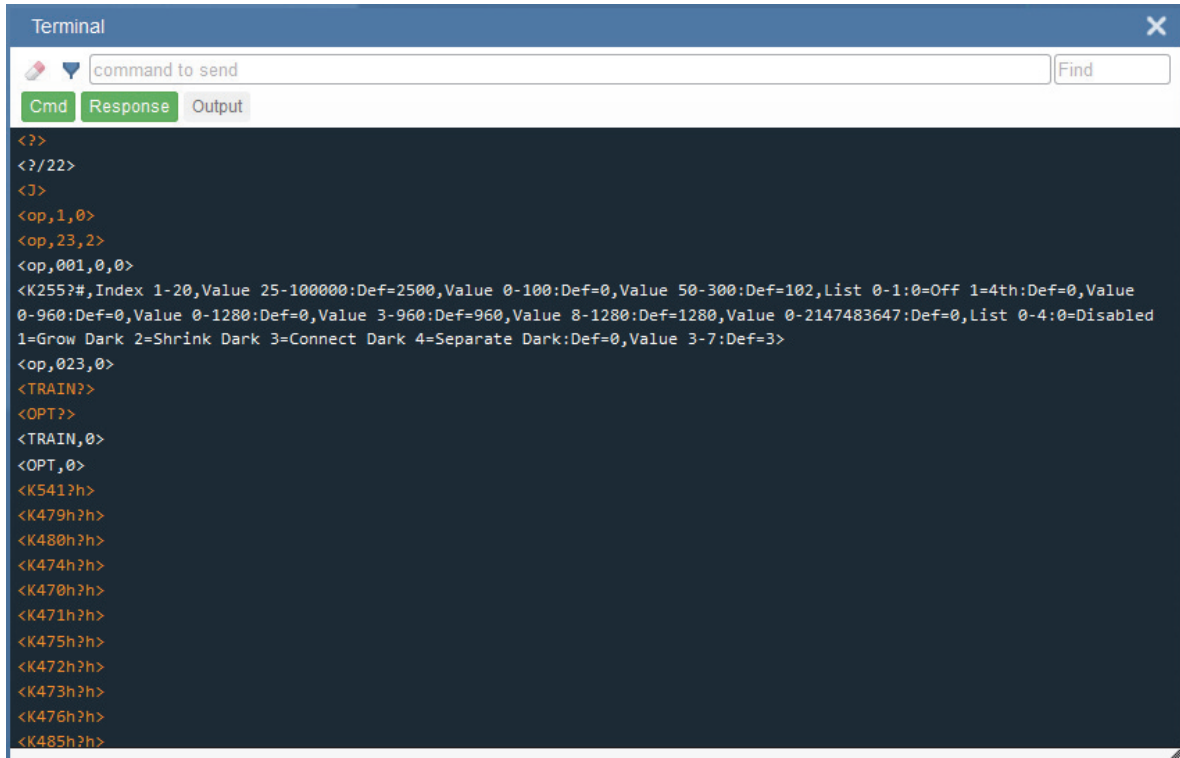

```

Terminal
command to send Find
Cmd Response Output
<?>
<?/22>
<J>
<op,1,0>
<op,23,2>
<op,001,0,0>
<K255?#,Index 1-20,Value 25-100000:Def=2500,Value 0-100:Def=0,Value 50-300:Def=102,List 0-1:0=Off 1=4th:Def=0,Value
0-960:Def=0,Value 0-1280:Def=0,Value 3-960:Def=960,Value 8-1280:Def=1280,Value 0-2147483647:Def=0,List 0-4:0=Disabled
1=Grow Dark 2=Shrink Dark 3=Connect Dark 4=Separate Dark:Def=0,Value 3-7:Def=3>
<op,023,0>
<TRAIN?>
<OPT?>
<TRAIN,0>
<OPT,0>
<K541?h>
<K479h?h>
<K480h?h>
<K474h?h>
<K470h?h>
<K471h?h>
<K475h?h>
<K472h?h>
<K473h?h>
<K476h?h>
<K485h?h>

```

### 7-3-3 Output

When the **Output** filter button is selected, decode output from the reader is shown. When only the Output button is selected, only decode output from the reader is shown.

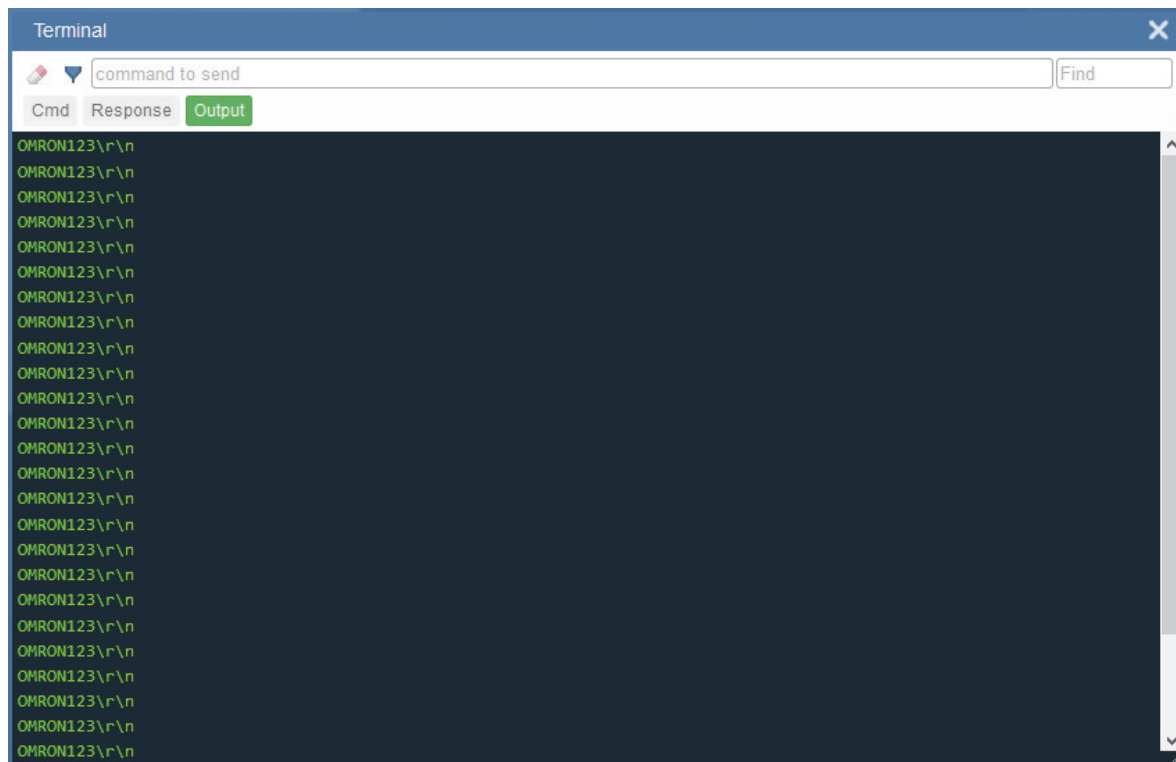

### 7-3-4 Notifications

If character strings searched for in the **Find** field are found but hidden by a disabled filter, a notification like the one shown below will appear above the applicable filter button. If you click that filter button, the results will be displayed in the Terminal and the notification will disappear.





# 8

## Advanced Settings

---

This section provides general information about the MicroHAWK's **Advanced Settings**, which can be configured in WebLink's user interface.

---

8-1	Introduction .....	8-2
8-2	Camera Setup .....	8-3
8-3	Communications .....	8-4
8-4	Read Cycle .....	8-7
8-5	Symbologies .....	8-8
8-6	I/O .....	8-14
8-7	Symbol Quality .....	8-32
8-8	Match String .....	8-33
8-9	Diagnostics .....	8-34
8-10	Image Storage .....	8-35
8-11	Configuration Database .....	8-36
8-12	Differences from Default .....	8-37

## 8-1 Introduction

When you click the **gear icon** to bring up the **Application Settings** menu, one of the options you will see is **Advanced**.

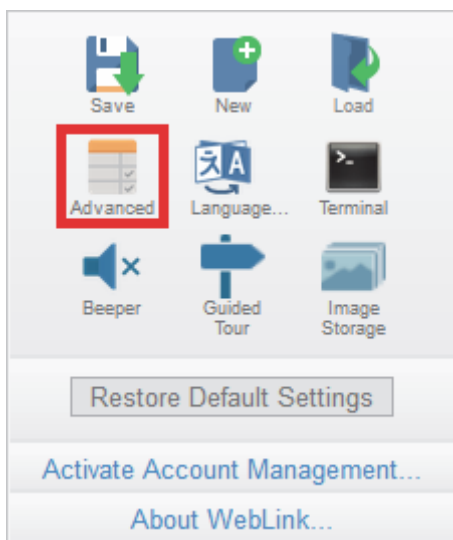

WebLink's **Advanced** settings allow you to make fine adjustments to individual command parameters in all areas of your reader's functionality: **Camera Setup, Communications, Read Cycle, Symbologies, I/O, Symbol Quality, Match String, Diagnostics, Image Storage, and Configuration Database**. Many of these commands can be configured directly in the WebLink user interface, but all parameters can be configured and examined in Advanced settings.

Advanced settings are an efficient way to send complex, multi-parameter commands to the reader.

Each menu of Advanced settings commands is shown in the following sections, and an additional section is included that shows an example of the **Differences from Default** menu, which shows only commands that are different from WebLink defaults.

## 8-2 Camera Setup

The **Camera Setup** menu shows all the commands that control the function of the reader's camera. Many of these command settings can also be controlled from the WebLink user interface. For example, the **Exposure** and **Gain** settings in the **Camera Settings** command can be configured in the **Acquire** section located in the left panel of the **Setup** view.

Command parameters can be changed directly from this menu.

### 8-2-1 Camera Setup Menu

Advanced Settings	
Camera Setup	Communications
Read Cycle	Symbologies
I/O	Symbol Quality
Match String	Diagnostics
Image Storage	Configuration Database
Search for settings	
<b>Camera Settings</b>	
☆ Exposure	4675 $\mu$ s
☆ Gain	0 %
★ Pixel Binning	Disabled
<b>Illumination</b>	
☆ Illumination Brightness	High
☆ Light Source	Outer LED Only
☆ Fixed Light On Time	0 $\mu$ s
☆ Fixed Light Delay Time	0 $\mu$ s
<b>Window of Interest</b>	
☆ Top	0
☆ Left	0
☆ Height	960
☆ Width	1280
<b>Image Processing Settings</b>	
☆ Damaged Symbol Status	Disabled
<b>Focus</b>	
☆ Focus Distance	250
☆ Distance Units	Millimeters
☆ Focus Mode	Normal
☆ No Read Limit	5
<b>Morphological Preprocessing</b>	
☆ Morphological Preprocessing	Disabled
☆ Operation	Grow Dark
☆ Size	Small

**Note:** When **Illumination Brightness** is set to **Constant**, the illumination brightness is the same power level as the **High** setting. However, the LEDs are continuously on once Brightness is set to Constant, and they will remain on during and after the read cycle to eliminate perceptible flashing.

## Power Strobe Mode and External Strobe

☆	<i>Illumination Brightness</i>	<i>Extreme</i>
☆	<i>Light Source</i>	<i>External Strobe</i>
☆	Fixed Light On Time	0
☆	Fixed Light Delay Time	0

### ● Power Strobe Mode

Activate **Power Strobe** mode by setting **Illumination Brightness** (<K536>) to **Extreme** and setting **Light Source** to **External Strobe**.

### ● External Strobe

**External Strobe** is part of the **Light Source** parameter.

### ● Fixed Light On Time and Fixed Light Delay Time

**Fixed Light On Time** and **Fixed Light Delay Time** are only valid when **Illumination Brightness** is set to **Extreme**.

## Use as External Illumination Strobe

**Use as External Illumination Strobe** is available in the **Output On** parameter of the **Output 3** command (<K812>) in **I/O Parameters**. **External Strobe** must be enabled for this parameter to function.

▼	<i>Output 3 Parameters</i>
☆	<i>Output On</i> <i>Use as Ext. Illumination Strobe</i>

## Lighting Mode Table

Lighting Mode	Inner LEDs	Outer LEDs	Off	On	Strobe	Power Strobe Inner LEDs	Power Strobe Outer LEDs	External Strobe
Engine USB Power	Yes	No	Yes	Yes	Yes	No	N/A	No
Engine External Power	Yes	No	Yes	Yes	Yes	No	N/A	Yes
V320-F / F320-F USB Power	Yes	No	Yes	Yes	Yes	No	N/A	Yes
V320-F / F320-F External Power	Yes	No	Yes	Yes	Yes	No	N/A	Yes
V330-F / F330-F	Yes	No	Yes	Yes	Yes	No	N/A	No
V420-F / F420-F USB Power	Yes	Yes	Yes	Yes	Yes	No	No	Yes
V420-F / F420-F External Power	Yes	Yes	Yes	Yes	Yes	No	Yes	Yes
V430-F / F430-F (Standard Type)	Yes	Yes	Yes	Yes	Yes	No	Yes	Yes
V430-F / F430-F (Ring Type)	N/A	Yes	Yes	Yes	Yes	No	Yes	Yes

## 8-3 Communications

The **Communications** menu shows all the commands that control the MicroHAWK's connectivity to the host and to your application's network. These commands also control **Preamble** and **Postamble** settings for decoded data output, **Response Timeout**, **LRC Status**, **ACK/NAK Options**, and **Polling Mode Options**.

By default, the MicroHAWK reader operates as a server, and communicates with the host over TCP/IP for both commands and data.

Command parameters can be changed directly from this menu.

### 8-3-1 Communications Menu

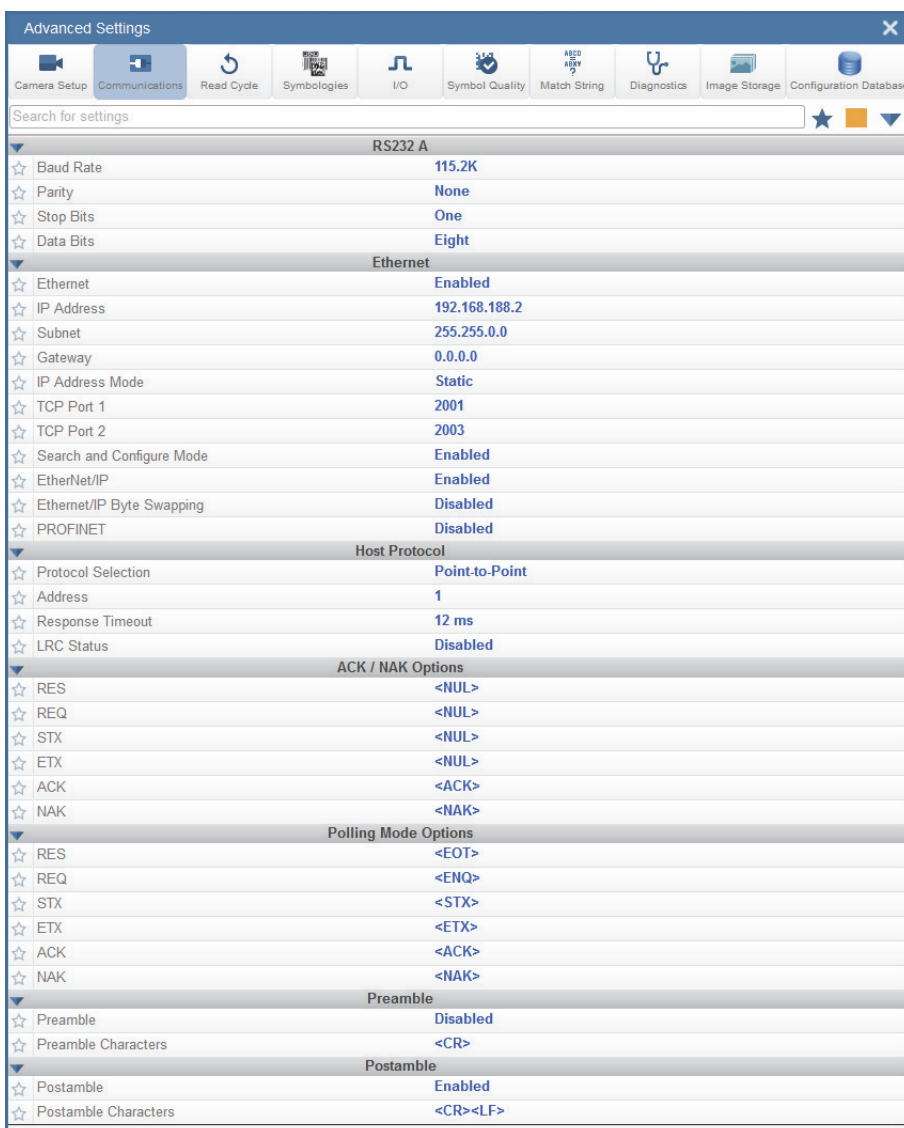

By default, the MicroHAWK reader operates as a server, and communicates with the host over TCP/IP for both commands and data.

See **Custom Ethernet Link** in **Appendix D – Communications** for information about how to create an Ethernet interface that is bound to the command processor per your own requirements. You can set the **Transport Layer** to **UDP** or **TCP**, set the message **Type** to **Server** or **Client**, and set **Capabilities** to **Send Only**, **Receive Only**, or **Send/Receive**.

## Daisy Chain

The **Daisy Chain** section, located beneath the **Postamble** section in the **Communications Menu** in **Advanced Settings**, allows you to enable or disable **Daisy Chain ID** functionality. Daisy Chain ID outputs the name of the reader that decoded the candidate symbol. It also allows you to determine the type of separator you want to appear between the reader ID and the barcode data output.

In the example below, Daisy Chain ID is **Enabled** and the Separator is set to **:**.

Daisy Chain	
☆ <i>Daisy Chain ID</i>	<i>Enabled</i>
☆ <i>Separator</i>	<i>:</i>

Those two settings cause the data output to look like the example below.

The reader ID is **V430-F3AF8FF**.

The **:** character is displayed between the reader ID and the symbol data output.

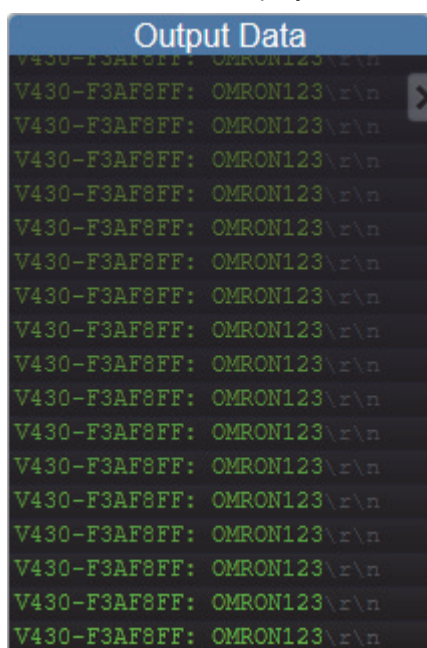

See [Configure Daisy Chain](#) for more information about general Daisy Chain functionality.

## EtherNet/IP and PROFINET Byte Swapping

EtherNet/IP Byte Swapping and PROFINET Byte Swapping allow you to switch the order in which bytes are transmitted (big-endian or little-endian) between the camera and the PLC. If enabled, the bytes are swapped for 2-byte words.

☆ EtherNet/IP	<i>Enabled</i>
☆ EtherNet/IP Byte Swapping	<i>Disabled</i>
☆ PROFINET	<i>Disabled</i>
☆ PROFINET Byte Swapping	<i>Disabled</i>



## 8-4 Read Cycle

The **Read Cycle** menu shows all the commands that control all aspects of read cycle, including triggering, read cycle timing, and image processing.

Command parameters can be changed directly from this menu.

### 8-4-1 Read Cycle Menu

Advanced Settings	
Camera Setup	Communications
<b>Read Cycle</b>	Symbologies
I/O	Symbol Quality
Match String	Diagnostics
Image Storage	Configuration Database
Search for settings	
<b>Multisymbol</b>	
☆ Number of Symbols	1
☆ Multisymbol Separator	,
<b>Trigger</b>	
☆ <b>Mode</b>	<i>Continuous Read</i>
☆ Leading Edge	32 $\mu$ s
☆ Trailing Edge	32 $\mu$ s
☆ External Trigger State	<i>Active Closed</i>
<b>Serial Trigger</b>	
☆ Character (Delimited)	<SP>
☆ Start Character (Non-Delimited)	<NUL>
☆ Stop Character (Non-Delimited)	<NUL>
<b>End of Read Cycle</b>	
☆ Mode	<i>Timeout</i>
☆ Read Cycle Timeout	500 ms
☆ Decodes Before Output	1
<b>Capture Mode</b>	
☆ Capture Mode	<i>Continuous</i>
☆ Number of Captures	1
☆ Rapid Capture Mode	<i>Timed Capture</i>
☆ Number of Continuous Captures	2
☆ Images per Read Cycle	10
☆ Read Cycle History	10
<b>Capture Time</b>	
☆ Time Before 1st Capture	0 $\mu$ s
☆ Time Between Captures 1-2	0 $\mu$ s
☆ Time Between Captures 2-3	0 $\mu$ s
☆ Time Between Captures 3-4	0 $\mu$ s
☆ Time Between Captures 4-5	0 $\mu$ s
☆ Time Between Captures 5-6	0 $\mu$ s
☆ Time Between Captures 6-7	0 $\mu$ s
☆ Time Between Captures 7-8	0 $\mu$ s
<b>Store No Read Image</b>	
☆ Image Storage Type	<i>Disabled</i>
☆ Image Storage Mode	<i>First Image</i>
<b>Image Processing Settings</b>	
☆ Image Processing Timeout	5000 ms

# 8-5 Symbologies

The **Symbologies** menu shows all the commands that allow you precise control of the parameters of all enabled code types. Parameters differ depending on the unique standards of each code type.

Command parameters can be changed directly from this menu.

## 8-5-1 Symbologies Menu

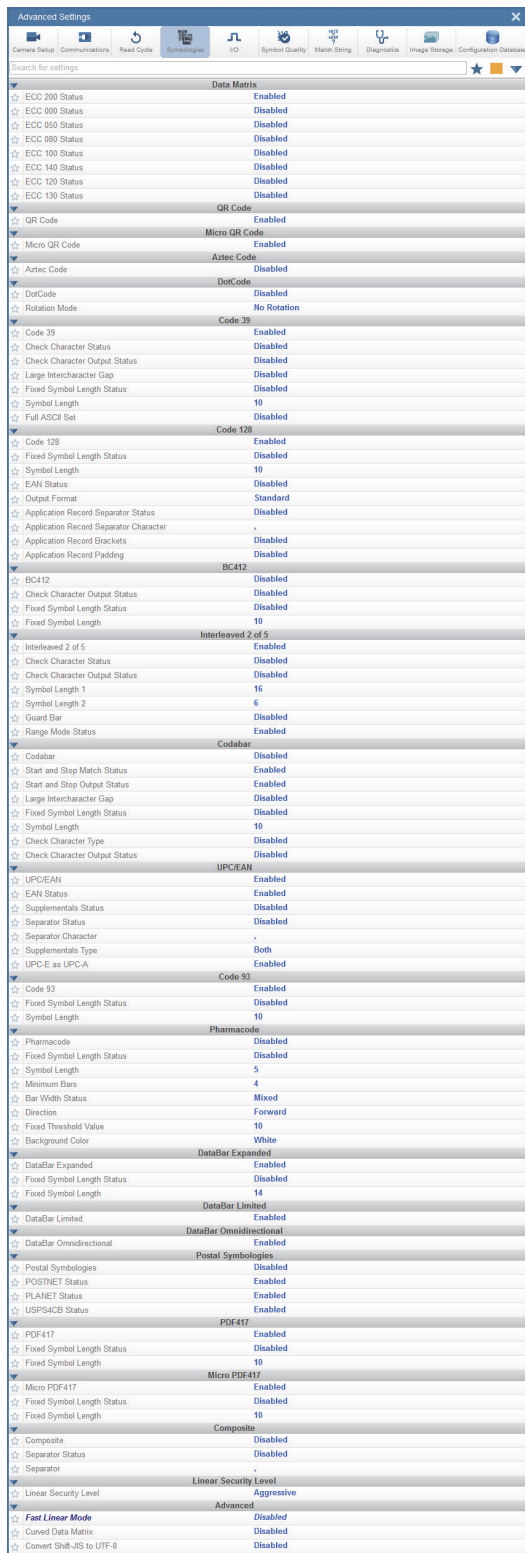

## 8-5-2 Advanced Decoding Parameters

**Advanced Decoding Parameters** can help you read difficult and damaged symbols, and are optimized for direct part marks (DPM).

Advanced	
☆ <i>Fast Linear Mode</i>	<i>Vertical</i>
☆ Curved 2D	Disabled
☆ Convert Shift-JIS to UTF-8	Disabled
☆ 1D Quiet Zone Violation	Disabled
☆ <i>Scale Image</i>	<i>Both Up and Down</i>
☆ 2D Damaged Mode	Disabled
☆ Attempt Morphology Manipulation	Disabled

### Fast Linear Mode

**Definition:** **Fast Linear Mode** optimizes 1D symbol decoding. Fast Linear Mode accelerates 1D decode speeds by restricting the orientation in which barcodes can be aligned, and only decoding barcodes in that orientation.

If you know the direction the application's symbols will be oriented relative to the reader (horizontally or vertically), set Fast Linear Mode to match that direction. This will cause the reader to decode only symbols in that orientation, thereby reducing the processing needed and speeding up decode times.

If you prefer serial commands to WebLink's Advanced Settings menus, you can use the following serial command to enter your Fast Linear Mode configuration efficiently in a Terminal.

**Serial Cmd:** `<K562,Fast Linear Mode>`

**Default:** **Disabled**

**Options:** **0 = Disabled**

1 = Horizontal

2 = Vertical

**Examples:** `<K562,0>` = Disabled

`<K562,1>` = Horizontal

`<K562,2>` = Vertical

**Horizontal** requires that the entire symbol be oriented horizontally in the reader's field of view.



**Vertical** requires that the entire symbol be oriented vertically in the reader's field of view.



## Curved 2D

*Definition:* **Curved 2D** is designed for **Data Matrix** and **QR Code** symbols on bottles and other cylinders.



**Data Matrix  
on Curved  
Surface**



**QR Code  
on Curved  
Surface**

Curvature in a captured image is usually created when the reader is pointing to the symbol at an angle. This algorithm, when enabled, will only be activated when the curvature is great enough. If the length ratio between the red and green line shown in the example below is greater than **20:1**, the Curved 2D algorithm will be activated.

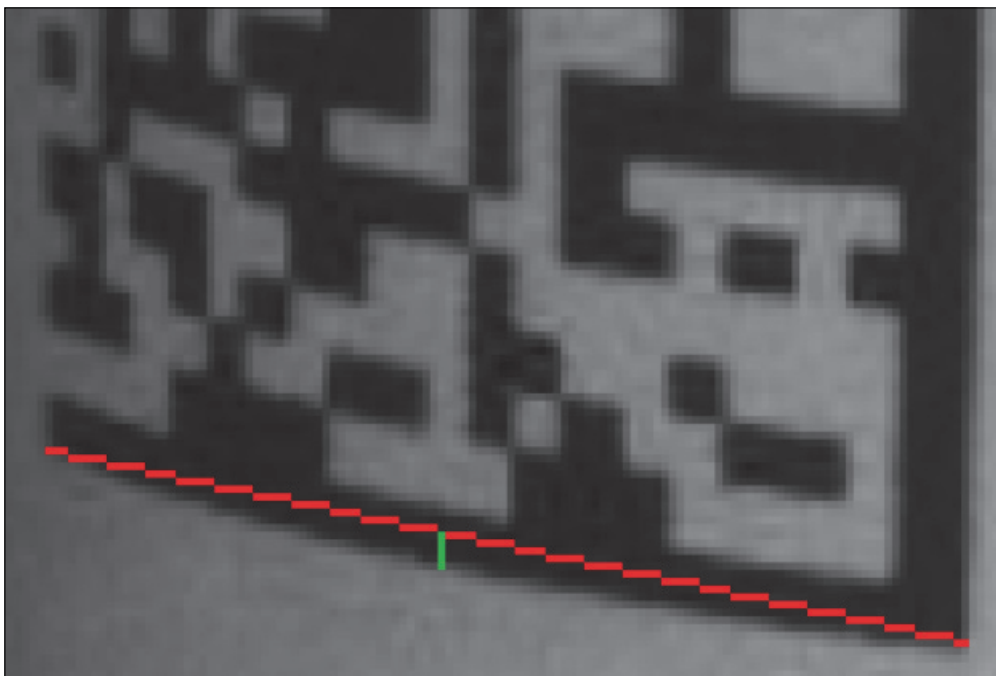

If you prefer to use serial commands, the following command allows you to enter your settings via a Terminal.

*Serial Cmd:* **<K563,Curved 2D>**

*Default:* **Disabled**

*Options:* **0 = Disabled**

**1 = Enabled**

## Convert Shift-JIS to UTF-8

*Definition:* For any symbol (often QR Code but not always), this feature converts decoded **Shift-JIS** characters to **UTF-8** characters.

*Serial Cmd:* **<K564,Convert Shift-JIS to UTF-8>**

*Default:* **Disabled**

*Options:* **0 = Disabled**

**1 = Enabled**

## 1D Quiet Zone Violation

*Definition:* This feature allows a symbol to be decoded even when there is noise in the quiet zone on one or both sides of a symbol. This command is specific to UPC, Code 128, Code 39, and Codabar.

*Serial Cmd:* <K565,1D Quiet Zone Violation>

*Default:* **Disabled**

*Options:* **0 = Disabled**  
1 = Enabled

## Scale Image

*Definition:* **Scale Image** allows you to scale the captured image up or down.

**Scale Up** is intended for symbols with low PPE (pixels per element) and small quiet zones. It scales up the image by 2x (4x by area). The maximum zoomed image size is 2600 x 2048. If the original image is greater than 1300 x 1024, it will be cropped to the center portion.

**Scale Down** scales the captured image to the ideal size for the reader's decoder (1/4 or 1/16 if necessary) and filters out image noise.

There is also a **Both** option that allows you to scale the image up or down.

*Serial Cmd:* <K566,Scale Image>

*Default:* **Disabled**

*Options:* **0 = Disabled**  
1 = Scale Up  
2 = Scale Down  
3 = Both

## 2D Damaged Mode

*Definition:* **2D Damaged Mode** allows you to decode symbols with distorted grid alignment or bad cell registration.

*Serial Cmd:* <K567,2D Damaged Mode>

*Default:* **Disabled**

*Options:* **0 = Disabled**  
1 = Enabled

## Attempt Morphology Manipulation

*Definition:* **Attempt Morphology Manipulation** applies morphology dilation and attempts to decode. If this isn't successful, it applies morphology erosion and attempts to decode.

*Serial Cmd:* <K568,Attempt Morphology Manipulation>

*Default:* **Disabled**

*Options:* **0 = Disabled**  
1 = Enabled

## Advanced Decoding Parameters Examples

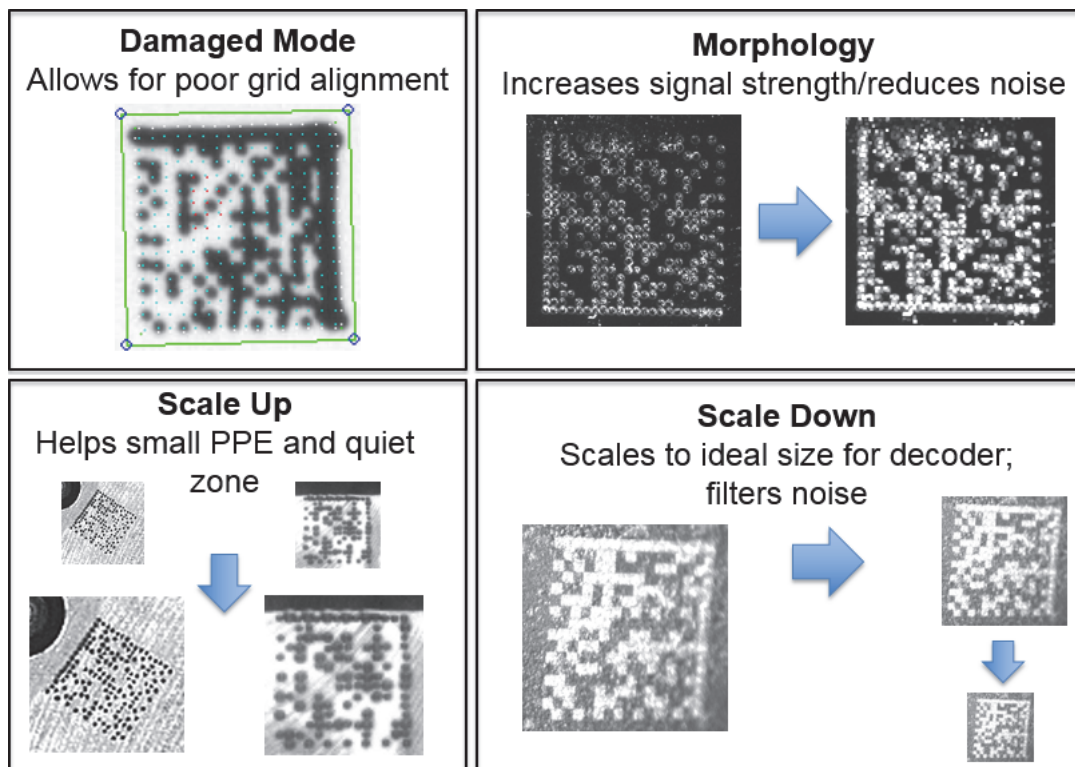

*Examples of 2D Damaged Mode, Attempt Morphology Manipulation, Scale Image Up, and Scale Image Down*

## Combining Advanced Decoding Parameters

Some Advanced Decoding Parameters can be combined and others cannot, as follows:

- **Curved 2D** and **Convert Shift-JIS to UTF-8** can be combined with each other, and both will be activated.
- **Scale Up**, **Scale Down**, **Attempt Morphology Manipulation**, and **2D Damaged Mode** can be combined with each other.
- **Fast Linear Mode Horizontal** and **Fast Linear Mode Vertical** cannot be combined with other Advanced Decoding Parameters commands.
- **1D Quiet Zone Violation** cannot be combined with other Advanced Decoding Parameters commands.

### 8-5-3 DotCode

**DotCode** is a special code type that can be enabled using the standard Code Type dialog box or using Advanced Settings.

**Important:** When DotCode is enabled, no other symbologies will be decodable. You must disable DotCode to decode symbols of any other type.

DotCode parameters can be found in the Symbologies menu located in WebLink's Advanced Settings.

By default, DotCode will look for either horizontal or vertical codes with no rotation (plus or minus 3 degrees). The user can set Rotation Mode to Low Rotation (plus or minus 10 degrees) or to Omni Directional.

DotCode		
☆	DotCode	Enabled
☆	Rotation Mode	No Rotation

When using DotCode, the user can specify the exact number of rows and columns in the code to minimize the possibility of decoding errors and no reads. If you specify the exact row and column dimensions, only DotCode symbols of the same dimension are decoded.

To do this, you must enter the row and column values using a K command via the Terminal under Settings, or via another serial link.



**Important:** DotCode must be enabled for the column and row settings to take effect.

**Serial K Command:** <K561,Custom Feature Command String>

*Default Setting:* “ ”

*Options:* DOTCODE\_COL\_ROW=?#?#

The ? character in DOTCODE\_COL\_ROW=?#?# should be changed to the expected number of columns and rows in the DotCode symbol.

In the example below, **40** is the number of columns, and **7** is the number of rows.

<K561,DOTCODE\_COL\_ROW=**40#7#**>



Swap columns and rows when the same symbol is oriented vertically.

<K561,DOTCODE\_COL\_ROW=**7#40#**>







## 8-6-2 Symbol Grading

### Grading Overview

The symbol grading features presented in this document are not intended and should not be confused with symbol verification. Verifier and symbol verification is beyond the scope of this document but there are a few points worth noting to aid in understanding the features and operation provided.

Verifiers are systems designed to meet the rigorous standards within the verification specifications. To provide compliant verification verifier systems are not only designed with required features and functionality from the supported standard but also provide many general design features that help eliminate sources of variability that can impact measurements. In contrast readers are designed to provide maximum product flexibility for integration into systems that require reading for traceability. Key reader design specifications such as size, cost, reading range, and reading speed are a few items that drive differences between verifier and reader designs. Understanding these tradeoffs in design can help users optimize reader systems to provide better accuracy and repeatability in grading implementation.

#### ● Calibration

Compliant verification requires verifiers have calibration processes. These processes are required to ensure proper references for grading metrics. The MicroHAWK provides no calibration features. It is the user's responsibility to understand how lack of calibration may impact their grading measurements. In addition, some metrics in verification such as Minimum Reflectance in ISO 29158 are directly calculated using data only provide through calibration and have no means of representation without such a process.

#### ● Optical Positioning and Illumination Response

The presentation of the symbol to the reader can have numerous different impacts on grading performance. Verifiers are designed to provide an image with sharp focus, high resolution, and low optical distortion. These items allow verifiers to provide an environment that produces measurements with consistent results. When selecting and positioning a reader for grading it is important that the optical setup provide enough resolution to meet the minimum resolution requirements for that standard (reference standard section for resolution requirements). Although resolution is important the working distance from the imaging optics also plays a significant role in the light collection and optical distortion characteristics of the image system. Further away provides less optical distortion over the field of view but also will have significant impact on the distribution of light depending on the source of illumination. When preparing a system for a grading implementation you must take these items under consideration. First identify the allowable working distances that will provide the target symbols in focus and above the minimum required resolution. Next attempt to provide the most consistent illumination response over the inspection field at the farthest distance. The change in illumination response over distance will be very dependent on the illumination source and environment. Finally, the orientation and consistency of the symbol presentation within the field of view can also impact repeatability. If the illumination response is uneven in the field and the symbol rotated or moves throughout the field you can expect variability.

## General Grading Functionality

---

### ● Process Overview

The three specification grading functions described in this document are independent of each other as an inspection process but are dependent on the X Mode decoder being properly setup to read the symbol type provided. The grading evaluation process does not take place until a symbol has first been identified by the X Mode decoder. Once a symbol supported by an enabled grading specification has been identified by the decoder a separate grading inspection will commence. Note this inspection process can add significant processing time to the overall process and each specification requires independent processing. Furthermore, enabling any single parameter within a given specification requires the complete grading process for that specification.

## Grading - ISO 15416

---

### ● Overview

This section outlines the grading implementation for ISO 15416 available in the MicroHAWK firmware. Please refer to the free AIM guide “The Layman's Guide to ANSI, CEN and ISO/IEC Linear Bar Code Print Quality Documents” or the ISO specification documents for additional detail related print quality subject matter.

### ● Supported Symbologies

- Code 128 / GS1-128
- UPC-A / UPC-E / EAN-13 / EAN-8
- Interleaved 2 of 5 / ITF-14
- Code 39
- Code 93
- Codabar

### ● Minimum Resolution

- 4.0 Pixels Per Element (Element = Nominal X Dimension)

## Usage / Notes

---

### ● Illumination and the Scan Reflectance Profile

The accuracy and consistency of ISO 15416 grading depends greatly upon the illumination in the field of view. The ISO 15416 specification is evaluated by analyzing individual scan lines applied across the imaged symbol. These scan lines generate a signal called the scan reflectance profile which is the basis of the scan line grading methodology. This scan line grading methodology uses a fixed threshold to determine whether the signal state represents a bar or a space. Verification systems are designed to create a very flat relative signal response across the field of view. For reading a symbol there is a high tolerance to variability in the response. When grading or verifying a symbol a flat relative response is what allows the symbol to be precisely measured. Different optical configurations and illumination sources can create a wide range of responses that can impact measurements in a variety of ways.

To illustrate how variation that appears subtle to the eye can have a large impact on grading performance consider the following image from a standard reader using internal illumination. The scan reflectance profile for two line scans in the image are shown to the right of the imaged symbols. The larger symbol which spans the entire field of view shows dramatic differences. The spaces in the center of the symbol are providing 50% more signal response than the quiet zones at either edge of the field of view. Similarly, the smaller symbol lower in the field of view provides a much lower overall response throughout its region. Scenarios like this will create low modulation scores and differences in defect scores depending on the physical location of the defect. Worse yet if the symbol is moved within the field of view it will receive different scores. It is recommended that external illumination is used and evaluated closely for response characteristics when using ISO 15416 grading.

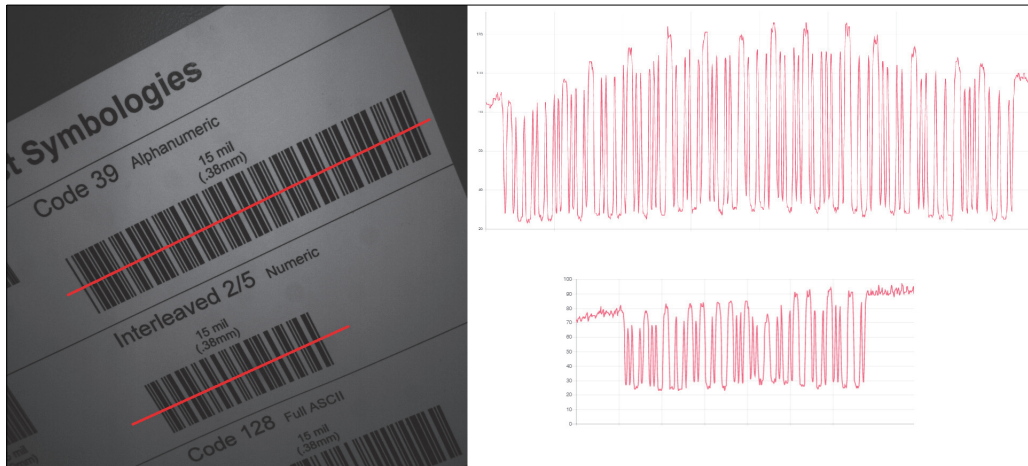

### Uneven Illumination

#### ● Synthetic Aperture

The synthetic aperture is a process in ISO 15416 that is applied to the image when extracting the scan line profile for grading. The aperture is an averaging process using a circular region along the scan line shown below.

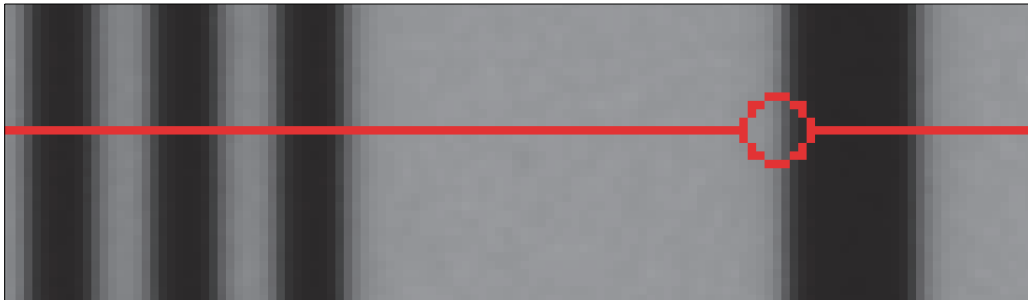

### Scan Line Aperture

This averaging provides a generalization of the information in the image consistent with typical reading equipment acquisition techniques. Verification systems implement the aperture based on the physical dimension of the symbol under test and the application standard guidelines such as GS1. In a reader with varying optical setup and no calibration process there is no means to know the size of the symbol under inspection. Because of this the aperture is a configurable parameter as a percentage of the narrow element of the symbol under evaluation. The default value provides a general use case similar to application standards, but it is the users responsibility to ensure this percentage matches the grading objectives. A representation of the effects of the aperture is shown below. Selecting a larger aperture creates more of an averaging effect that is less sensitive to defects but may lower modulation.

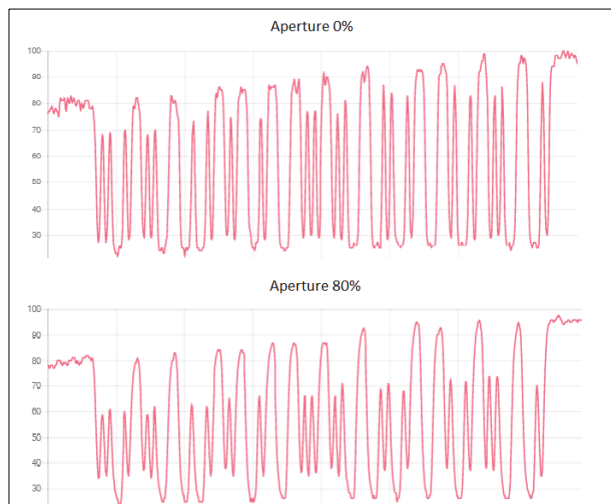

### Aperture Effects

#### ● Overall, Scan, and Individual Parameter Grades

The overall grade is calculated in accordance with the process defined in ISO 15416. This is often misunderstood so a review is provided here. The overall grade is an average of the individual scan grades that are applied over the inspection region. The individual scan grades are not provided but these are calculated internally as the lowest of grade of any single parameter grade evaluated in that scan or zero if the scan fails the edge determination or quiet zone requirements. The individual parameter grades provided are averages of only those parameters grades where they are evaluated. These individual average parameter grades available are not themselves part of the overall grade calculation but can be helpful information for diagnosing degrading overall grades. This creates some circumstances where the overall grade can be lower than the lowest average grade particularly when there are degrading features in the symbol from different parameters.

## Configuration

#### ● 15416 Grading Serial Output

Enable or disable the output the grading value. The output is either in value 1 to 100, or in letter grade A to F.

#### ● Aperture

The size of aperture to use for grading configured as a percentage of the nominal narrow element width for the symbol under evaluation. For example, if you have a 13 mil UPC symbol and you wish to grade using a 6 mil aperture you would configure the aperture to 46% ( $6/13 = 0.46$ ).

#### ● Overall

##### Disabled

The overall grade is not formatted as part of the symbol output.

**Enabled**

The overall grade is formatted and attached to the decoded data as a value.

**● Edge Determination****Disabled**

The edge determination is not formatted as part of the symbol output.

**Enabled**

The edge determination is formatted and attached to the decoded data as a value.

**● Decode****Disabled**

The Decode is not formatted as part of the symbol output.

**Enabled**

The Decode is formatted and attached to the decoded data as a value.

**● Contrast****Disabled**

The Contrast is not formatted as part of the symbol output.

**Enabled**

The Contrast is formatted and attached to the decoded data as a value.

**● Minimum Reflectance****Disabled**

The minimum reflectance is not formatted as part of the symbol output.

**Enabled**

The minimum reflectance is formatted and attached to the decoded data as a value.

**● Minimum Edge Contrast****Disabled**

The minimum edge contrast is not formatted as part of the symbol output.

**Enabled**

The minimum edge contrast is formatted and attached to the decoded data as a value.

**● Modulation****Disabled**

The Modulation is not formatted as part of the symbol output.

**Enabled**

The Modulation is formatted and attached to the decoded data as a value.

**● Defects****Disabled**

The Defects is not formatted as part of the symbol output.

**Enabled**

The Defects is formatted and attached to the decoded data as a value.

- **Decodability**

**Disabled**

The Decodability is not formatted as part of the symbol output.

**Enabled**

The Decodability is formatted and attached to the decoded data as a value.

- **Quiet Zone**

**Disabled**

The Quiet Zone is not formatted as part of the symbol output.

**Enabled**

The Quiet Zone is formatted and attached to the decoded data as a value.

- **15416 Grading Logic Output and Threshold 1 - 3**

This parameter defines the 15416 parameter and threshold that if fallen below will assert the appropriate output. The output must be configured to output on 15416 validation before these settings apply.

- **Output on Overall Grade**

**Disabled**

This will not be evaluated to drive the output.

**Enabled**

This will be evaluated against the corresponding threshold to drive the output.

- **Overall Grade Threshold**

This is to use as a threshold for driving the output. Output will be driven if grade is under the threshold.

- **Edge Determination**

**Disabled**

This will not be evaluated to drive the output.

**Enabled**

This will be evaluated against the corresponding threshold to drive the output.

- **Edge Determination Threshold**

This is to use as a threshold for driving the output. Output will be driven if grade is under the threshold.

- **Decode**

**Disabled**

This will not be evaluated to drive the output.

**Enabled**

This will be evaluated against the corresponding threshold to drive the output.

- **Decode Threshold**

This is to use as a threshold for driving the output. Output will be driven if grade is under the threshold.

- **Contrast**

- **Disabled**

- This will not be evaluated to drive the output.

- **Enabled**

- This will be evaluated against the corresponding threshold to drive the output.

- **Contrast Threshold**

This is to use as a threshold for driving the output. Output will be driven if grade is under the threshold.

- **Min Reflectance**

- **Disabled**

- This will not be evaluated to drive the output.

- **Enabled**

- This will be evaluated against the corresponding threshold to drive the output.

- **Min Reflectance Threshold**

This is to use as a threshold for driving the output. Output will be driven if grade is under the threshold.

- **Min Edge Contrast**

- **Disabled**

- This will not be evaluated to drive the output.

- **Enabled**

- This will be evaluated against the corresponding threshold to drive the output.

- **Min Edge Contrast Threshold**

This is to use as a threshold for driving the output. Output will be driven if grade is under the threshold.

- **Modulation**

- **Disabled**

- This will not be evaluated to drive the output.

- **Enabled**

- This will be evaluated against the corresponding threshold to drive the output.

- **Modulation Threshold**

This is to use as a threshold for driving the output. Output will be driven if grade is under the threshold.

- **Defects**

- **Disabled**

- This will not be evaluated to drive the output.

**Enabled**

This will be evaluated against the corresponding threshold to drive the output.

- **Defects Threshold**

This is to use as a threshold for driving the output. Output will be driven if grade is under the threshold.

- **Decodability**

**Disabled**

This will not be evaluated to drive the output.

**Enabled**

This will be evaluated against the corresponding threshold to drive the output.

- **Decodability Threshold**

This is to use as a threshold for driving the output. Output will be driven if grade is under the threshold.

- **Quiet Zone**

**Disabled**

This will not be evaluated to drive the output.

**Enabled**

This will be evaluated against the corresponding threshold to drive the output.

- **Quiet Zone Threshold**

This is to use as a threshold for driving the output. Output will be driven if grade is under the threshold.

## Grade Metrics

---

- **Overall Grade**

The overall is calculated in accordance with the ISO 15416 specification. The overall grade is the average of the scan grades applied to the symbol. The individual scan grades are the lowest individual parameter grade seen during the individual scan. These scan grades are not available for output.

- **Minimum Reflectance**

The Minimum reflectance is calculated and graded for each scan and provided for the overall grade calculation in accordance with the ISO 15416 specification. The minimum reflectance parameter grade and value provided for output is an average value for each measured scan over the entire symbol.

- **Minimum Edge Contrast**

Contrast measurement assume 8 bit 0-255 grey correlate 0-100% reflectance The Minimum Edge Contrast is calculated and graded for each scan and provided for the overall grade calculation in accordance with the ISO 15416 specification. The parameter grade and value provided for output is an average value for each measured scan over the entire symbol.

- **Symbol Contrast**

Contrast measurements assume 8 bit 0-255 grey correlate to 0-100% reflectance. Contrast is calculated and graded for each scan and provided for the overall grade calculation in accordance with the ISO 15416 specification. The parameter grade and value provided for output is an average value for each measured scan over the entire symbol.



### ● Modulation

Modulation is calculated and graded for each scan and provided for the overall grade calculation in accordance with the ISO 15416 specification. The parameter grade and value provided for output is an average value for each measured scan over the entire symbol.

### ● Defects

Defects are calculated and graded for each scan and provided for the overall grade calculation in accordance with the ISO 15416 specification. The parameter grade and value provided for output is an average value for each measured scan over the entire symbol.

### ● Decodability

Decodability is calculated and graded for each scan and provided for the overall grade calculation in accordance with the ISO 15416 specification. The parameter grade and value provided for output is an average value for each measured scan over the entire symbol.

### ● Decode

Decode is calculated and graded for each scan and provided for the overall grade calculation in accordance with the ISO 15416 specification. The parameter grade and value provided for output is an average value for each measured scan over the entire symbol.

### ● Quiet Zone

Quiet zone is not an individually processed parameter within the ISO 15416 specification but is evaluated as part of the ISO graded decode parameter that feeds into the overall grade. Quiet zone is provided here as average scan result where a passing scan receives a A/4.0 grade and a fail receives a F/0.0.

## Grading - ISO 15415

### ● Overview

This section outlines the grading implementation for ISO 15415 available in the MicroHAWK firmware.

### ● Supported Symbologies

- Data Matrix ECC 200 / GS1 Data Matrix
- QR Code

### ● Minimum Resolution

- 6.0 Pixels Per Element (Element = Nominal Cell Dimension)

### ● Configuration

#### 15415 Grading Serial Output

Enable or disable the output the grading value. The output is either in value 1 to 100, or in letter grade A to F.

### ● Aperture

The size of aperture to use for grading configured as a percentage of the nominal narrow element width for the symbol under evaluation. For example, if you have a 15 mil UPC symbol and you wish to grade using a 10 mil aperture you would configure the aperture to 67% ( $10/15 = 0.67$ ).

### ● Overall

#### **Disabled**

The overall grade is not formatted as part of the symbol output.

#### **Enabled**

The overall grade is formatted and attached to the decoded data as a value.

### ● Contrast

#### **Disabled**

The contrast is not formatted as part of the symbol output.

#### **Enabled**

The contrast is formatted and attached to the decoded data as a value.

### ● Modulation

#### **Disabled**

The modulation is not formatted as part of the symbol output.

#### **Enabled**

The modulation is formatted and attached to the decoded data as a value.

### ● Reflectance Margin

#### **Disabled**

The reflectance margin is not formatted as part of the symbol output.

#### **Enabled**

The reflectance margin is formatted and attached to the decoded data as a value.

### ● Fixed Pattern Damage

#### **Disabled**

The fixed pattern damage is not formatted as part of the symbol output.

#### **Enabled**

The fixed pattern damage is formatted and attached to the decoded data as a value.

### ● Axial Non-Uniformity

#### **Disabled**

The axial nonuniformity is not formatted as part of the symbol output.

#### **Enabled**

The axial nonuniformity is formatted and attached to the decoded data as a value.

### ● Grid Non-Uniformity

#### **Disabled**

The grid nonuniformity is not formatted as part of the symbol output.

#### **Enabled**

The grid nonuniformity is formatted and attached to the decoded data as a value.

- **Unused ECC**

- Disabled**

- The unused ECC is not formatted as part of the symbol output.

- Enabled**

- The unused ECC is formatted and attached to the decoded data as a value.

- **15415 Grading Logic Output and Threshold 1 - 3**

This parameter defines the 15415 parameter and threshold that if fallen below will assert the appropriate output. The output must be configured to output on 15415 validation before these settings apply.

- **Output on Overall Grade**

- Disabled**

- This will not be evaluated to drive the output.

- Enabled**

- This will be evaluated against the corresponding threshold to drive the output.

- **Overall Grade Threshold**

This is to use as a threshold for driving the output. Output will be driven if grade is under the threshold.

- **Symbol Contrast**

- Disabled**

- This will not be evaluated to drive the output.

- Enabled**

- This will be evaluated against the corresponding threshold to drive the output.

- **Symbol Contrast Threshold**

This is to use as a threshold for driving the output. Output will be driven if grade is under the threshold.

- **Modulation**

- Disabled**

- This will not be evaluated to drive the output.

- Enabled**

- This will be evaluated against the corresponding threshold to drive the output.

- **Modulation Threshold**

This is to use as a threshold for driving the output. Output will be driven if grade is under the threshold.

- **Reflectance Margin**

- Disabled**

- This will not be evaluated to drive the output.

- Enabled**

- This will be evaluated against the corresponding threshold to drive the output.

● **Reflectance Margin Threshold**

This is to use as a threshold for driving the output. Output will be driven if grade is under the threshold.

● **Fixed Pattern Damage**

**Disabled**

This will not be evaluated to drive the output.

**Enabled**

This will be evaluated against the corresponding threshold to drive the output.

● **Fixed Pattern Damage Threshold**

This is to use as a threshold for driving the output. Output will be driven if grade is under the threshold.

● **Axial Non-Uniformity**

**Disabled**

This will not be evaluated to drive the output.

**Enabled**

This will be evaluated against the corresponding threshold to drive the output.

● **Axial Non-Uniformity Threshold**

This is to use as a threshold for driving the output. Output will be driven if grade is under the threshold.

● **Grid Non-Uniformity**

**Disabled**

This will not be evaluated to drive the output.

**Enabled**

This will be evaluated against the corresponding threshold to drive the output.

● **Grid Non-Uniformity Threshold**

This is to use as a threshold for driving the output. Output will be driven if grade is under the threshold.

● **Unused ECC**

**Disabled**

This will not be evaluated to drive the output.

**Enabled**

This will be evaluated against the corresponding threshold to drive the output.

● **Unused ECC Threshold**

This is to use as a threshold for driving the output. Output will be driven if grade is under the threshold.

## Grade Metrics

---

- **Overall Grade**

The overall is calculated in accordance with the ISO 15415 specification. The overall grade is the lowest individual parameter grade seen during the individual scan.

- **Symbol Contrast**

Contrast measurements assume 8 bit 0-255 grey correlate to 0-100% reflectance. Symbol Contrast is calculated in accordance with the ISO 15415 specification.

- **Modulation**

Reflectance Margin is calculated in accordance with the ISO 15415 specification.

- **Reflectance Margin**

Reflectance Margin is calculated in accordance with the ISO 15415 specification.

- **Fixed Pattern Damage**

Fixed Pattern Damage is calculated in accordance with the ISO 15415 specification.

- **Axial Non-Uniformity**

Axial Non-Uniformity is calculated in accordance with the ISO 15415 specification.

- **Grid Non-Uniformity**

Grid Non-Uniformity is calculated in accordance with the ISO 15415 specification.

- **Unused Error Correction**

Unused Error Correction is calculated in accordance with the ISO 15415 specification.

## Grading - ISO 29158

---

- **Overview**

This section outlines the grading implementation for ISO 29158 available in the MicroHAWK firmware.

- **Supported Symbologies**

- Data Matrix ECC200 / GS1 Data Matrix

- **Minimum Resolution**

- 6.0 Pixels Per Element (Element = Nominal Cell Dimension)

## Configuration

---

### ● 29158 Grading Serial Output

Enable or disable the output the grading value. The output is either in value 1 to 100, or in letter grade A to F.

#### ● Overall

##### Disabled

The overall grade is not formatted as part of the symbol output.

##### Enabled

The overall grade is formatted and attached to the decoded data as a value.

### ● Cell Contrast

##### Disabled

The contrast is not formatted as part of the symbol output.

##### Enabled

The contrast is formatted and attached to the decoded data as a value.

### ● Cell Modulation

##### Disabled

The modulation is not formatted as part of the symbol output.

##### Enabled

The modulation is formatted and attached to the decoded data as a value.

### ● Fixed Pattern Damage

##### Disabled

The fixed pattern damage is not formatted as part of the symbol output.

##### Enabled

The fixed pattern damage is formatted and attached to the decoded data as a value.

### ● Axial Non-Uniformity

##### Disabled

The axial nonuniformity is not formatted as part of the symbol output.

##### Enabled

The axial nonuniformity is formatted and attached to the decoded data as a value.

### ● Grid Non-Uniformity

##### Disabled

The grid nonuniformity is not formatted as part of the symbol output.

##### Enabled

The grid nonuniformity is formatted and attached to the decoded data as a value.

- **Unused ECC**

- Disabled**

- The unused ECC is not formatted as part of the symbol output.

- Enabled**

- The unused ECC is formatted and attached to the decoded data as a value.

- **29158 Grading Logic Output and Threshold 1 - 3**

This parameter defines the 29158 parameter and threshold that if fallen below will assert the appropriate output. The output must be configured to output on 29158 validation before these settings apply.

- **Output on Overall Grade**

- Disabled**

- This will not be evaluated to drive the output.

- Enabled**

- This will be evaluated against the corresponding threshold to drive the output.

- **Overall Grade Threshold**

This is to use as a threshold for driving the output. Output will be driven if grade is under the threshold.

- **Cell Contrast**

- Disabled**

- This will not be evaluated to drive the output.

- Enabled**

- This will be evaluated against the corresponding threshold to drive the output.

- **Cell Contrast Threshold**

This is to use as a threshold for driving the output. Output will be driven if grade is under the threshold.

- **Cell Modulation**

- Disabled**

- This will not be evaluated to drive the output.

- Enabled**

- This will be evaluated against the corresponding threshold to drive the output.

- **Cell Modulation Threshold**

This is to use as a threshold for driving the output. Output will be driven if grade is under the threshold.

- **Fixed Pattern Damage**

- Disabled**

- This will not be evaluated to drive the output.

- Enabled**

- This will be evaluated against the corresponding threshold to drive the output.

- **Fixed Pattern Damage Threshold**

This is to use as a threshold for driving the output. Output will be driven if grade is under the threshold.

- **Axial Non-Uniformity**

- Disabled**

- This will not be evaluated to drive the output.

- Enabled**

- This will be evaluated against the corresponding threshold to drive the output.

- **Axial Non-Uniformity Threshold**

This is to use as a threshold for driving the output. Output will be driven if grade is under the threshold.

- **Grid Non-Uniformity**

- Disabled**

- This will not be evaluated to drive the output.

- Enabled**

- This will be evaluated against the corresponding threshold to drive the output.

- **Grid Non-Uniformity Threshold**

This is to use as a threshold for driving the output. Output will be driven if grade is under the threshold.

- **Unused ECC**

- Disabled**

- This will not be evaluated to drive the output.

- Enabled**

- This will be evaluated against the corresponding threshold to drive the output.

- **Unused ECC Threshold**

This is to use as a threshold for driving the output. Output will be driven if grade is under the threshold.



## ISO 29158 Metrics

---

### ● Overall Grade

The **Overall Grade** is the minimum grade of all evaluated parameters, noting minimum reflectance is not evaluated.

### ● Cell Contrast

**Cell Contrast** is a measure of contrast that differs from ISO 15415 using a statistical value calculated from the measurements at the grid centers. Cell Contrast is calculated in accordance with the ISO 29158 specification.

### ● Cell Modulation

Like Cell Contrast, **Cell Modulation** is a modified version from ISO 15415. Cell Modulation is calculated in accordance with the ISO 29158 specification. Note that the difference in the calculation for Cell Modulation versus the Modulation parameter in ISO 15415 also eliminated the need for ISO 29158 to adopt Reflectance Margin, which was added to the ISO 15415 specification.

### ● Fixed Pattern Damage

**Fixed Pattern Damage** is an evaluation of the elements in the fixed patterns of the symbol that are used for locating and extracting the data successfully. Fixed Pattern Damage is calculated in accordance with the ISO 29158 specification.

### ● Axial Non-Uniformity

**Axial Non-Uniformity** measures the relationship between the overall dimensions of the two axes of the symbol. Axial Non-Uniformity is calculated in accordance with the ISO 29158 specification.

### ● Grid Non-Uniformity

**Grid Non-Uniformity** measures the difference of the decoding grid in relation to the ideal grid formed from the four corners of the symbol. Grid Non-Uniformity is calculated in accordance with the ISO 29158 specification.

### ● Unused Error Correction

**Unused Error Correction** measures the remaining error correction available after correcting the errors within the decoded symbol and is calculated in accordance with the ISO 29158 specification.

# 8-7 Symbol Quality

The **Symbol Quality** menu shows commands that allow you to define the evaluation of symbols per the ISO/IEC 16022 specification, or by a collection of commonly-used grading parameters. The two **Global** commands allow you to define the separator that will appear between instances of symbol quality output, and the format in which symbol quality evaluations will be output.

Command parameters can be changed directly from this menu.

## 8-7-1 Symbol Quality Menu

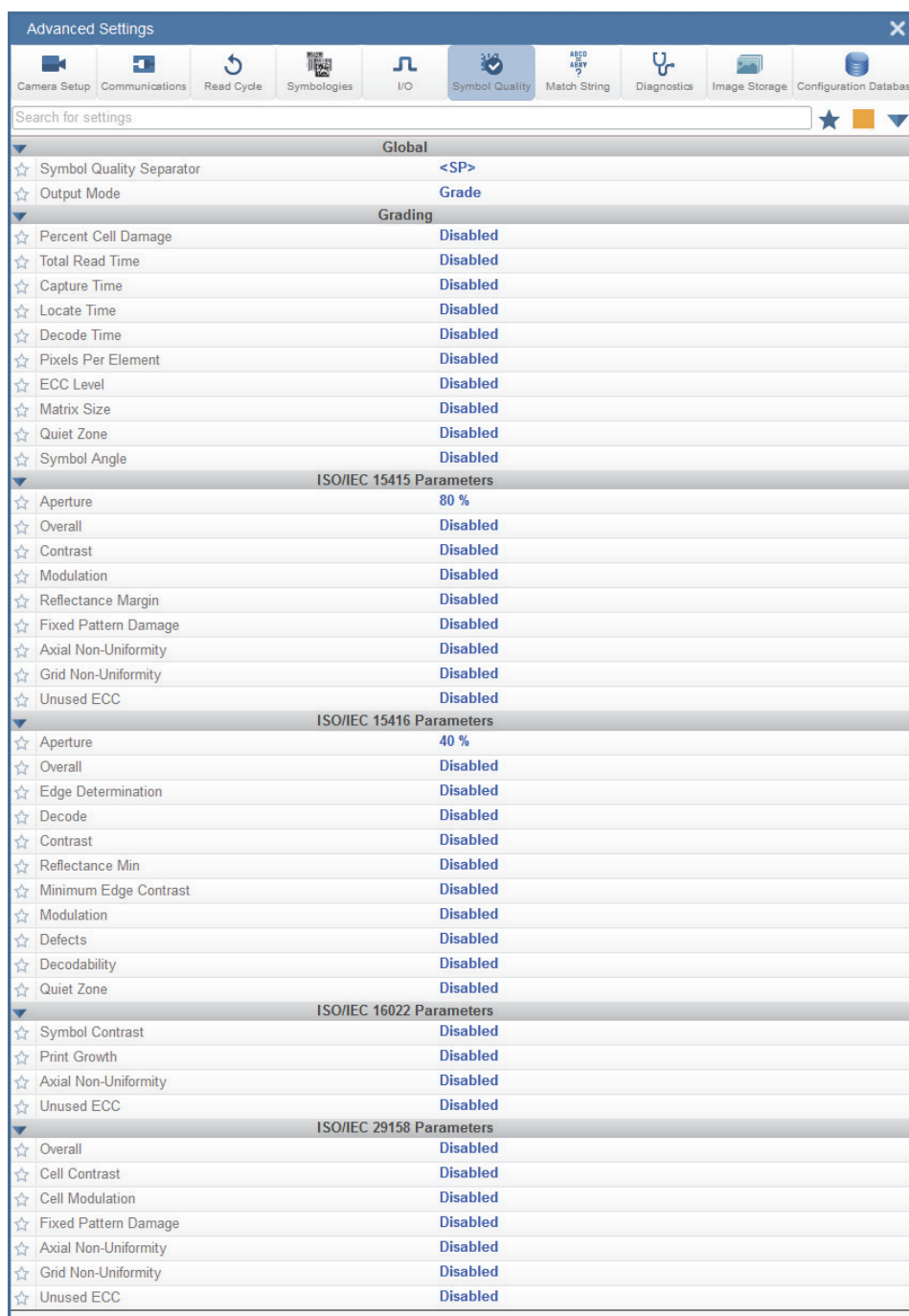

**Important:** For descriptions of symbol grading functionality, refer to the **Symbol Grading** section in [I/O](#).

## 8-8 Match String

**Note:** Match String can only be used in **Triggered**, **Start/Stop**, and **Custom** modes. It cannot be used in Presentation or Continuous modes.

The **Match String** menu shows all the commands that allow you to determine the type of matching behavior required of the reader, as well as new master pin functionality (enabled or disabled), and the character strings intended to replace a string of decoded data that is either a match or mismatch with the user-defined match string.

Command parameters can be changed directly from this menu.

### 8-8-1 Match String Menu



## 8-9 Diagnostics

The **Diagnostics** menu shows commands that allow you to change various service messages as well as the reader's name. It also allows you to examine the read-only count values for multiple reader functions and states.

Command parameters can be changed directly from this menu.

### 8-9-1 Diagnostics Menu

The screenshot shows the 'Advanced Settings' window with the 'Diagnostics' tab selected. The interface includes a search bar and several expandable sections:

- Counts:**
  - Power-on: 1 readonly
  - Resets: 9 readonly
  - Power-on Saves: 96 readonly
  - Custom Default Saves: 5 readonly
  - Total Reset Count: 10074 readonly
  - Flash Writes: 10843 readonly
- Hours Since Reset (Read-only):**
  - Hours: 2 readonly
  - Minutes: 4
- Service Message:**
  - Status: Disabled
  - Service Message: SERVICE
  - Threshold: 300
  - Resolution: Seconds
  - User-Defined Name: V430-F3A7BCB

## 8-10 Image Storage

The **Image Storage** menu shows commands that allow you to control how, when, and where images captured by the reader are stored.

The **Image Storage** and **Image Storage Location** commands shown below are functionally identical to those described in **Application Settings**. For example, when you configure the **FTP Address** command as shown below, the outcome is the same as it would have been had you used the graphic user interface accessible from the Application Settings menu.

Image Storage Location			
☆ <b>Image Storage Location</b>	<i>Remote (FTP)</i>		
☆ <b>FTP Address</b>	userid	pass	192.168.1.1 21
☆ Transfer Optimization	Speed		
☆ RAM Drive Size	20 MB		

Command parameters can be changed directly from this menu.

### 8-10-1 Image Storage Menu

The screenshot shows the 'Advanced Settings' application with the 'Image Storage' menu selected. The menu is organized into three main sections:

- Image Storage**
  - Image Storage Status: Disabled
  - Stored Image Type: No Read
  - Image Storage Mode: First image in a read cycle
  - Image File Format: PNG - High Resolution
  - Image Quality: 90 %
  - Image Scale: Full scale
  - File Save Options: Image
- Image Storage Location**
  - Image Storage Location: RAM (Volatile Memory)
  - RAM Drive Size: 20 MB
  - Save Image Until: New Read Cycle
  - Action at Image Storage Limit: Stop
- Image Output (Legacy)**
  - Image Output: Disabled
  - Comm Port: RS232
  - Stored Image Type: Disabled
  - Image Format: JPG - Low Resolution
  - Image Quality: 90 %
  - Decode Output: Disabled
  - Grade Output: Disabled

## 8-11 Configuration Database

The **Configuration Database** menu allows you to:

- Set the number of database records (groups of settings) that will be used automatically during the read cycle;
- Move the database entry that produced a successful decode to the first position in the list of database entries;
- Select the event that causes the reader to load the next database entry to current active settings;
- Determine the number of image frames that must be captured;
- Determine the amount of time that must transpire before the reader will load the next database index entry;
- Process a single captured image multiple times using different IP and decode parameters;
- Determine how the image dimension parameters will be implemented (Window of Interest or Region of Interest).

Command parameters can be changed directly from this menu.

### 8-11-1 Configuration Database Menu

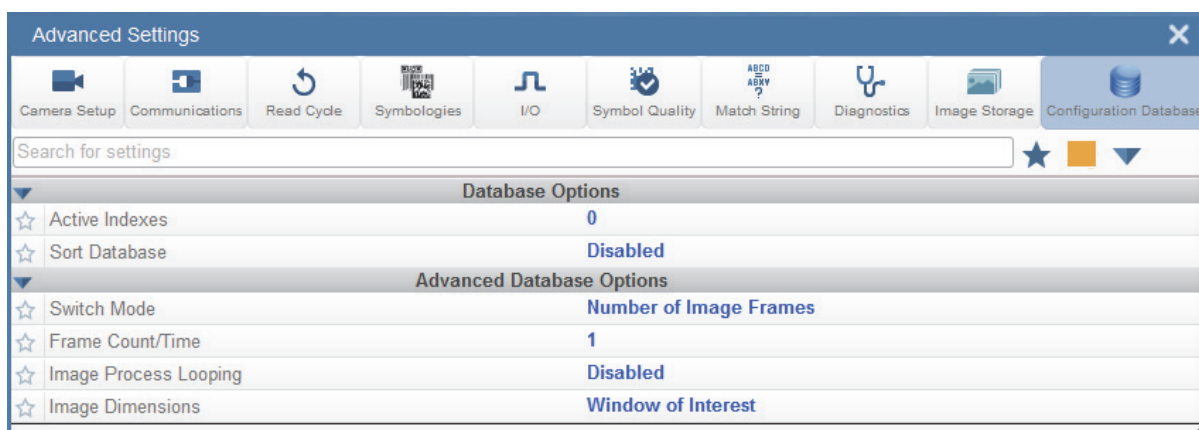

## 8-12 Differences from Default

The **Differences from Default** menu shows only commands whose parameters are not currently set to WebLink defaults. Commands from any of the eight categories may appear in this menu.

Command parameters can be changed directly from this menu.

### 8-12-1 Differences from Default Menu

The screenshot shows the 'Advanced Settings' window with a search bar and a list of settings grouped into categories. Each setting has a star icon on the left, indicating it is a difference from the default.

Advanced Settings	
Camera Setup	Communications
Read Cycle	Symbologies
I/O	Symbol Quality
Match String	Diagnostics
Image Storage	Configuration Database
Search for settings	
Camera Settings	
☆ Exposure	1299 $\mu$ s
☆ Gain	0 %
Focus	
☆ Focus Distance	1.96
☆ Distance Units	Inches
☆ Focus Mode	Normal
☆ Operation	Separate Dark
☆ Size	Large
Trigger	
☆ Mode	External Level
Data Matrix	
☆ ECC 000 Status	Enabled
Advanced	
☆ Fast Linear Mode	Disabled
Output Indicators	
☆ Green Flash Mode	Good Read
☆ Green Flash Duration	500 ms
Matchcode Type	
☆ Placeholder	?
☆ User-Defined Name	V430-F3A7BCB





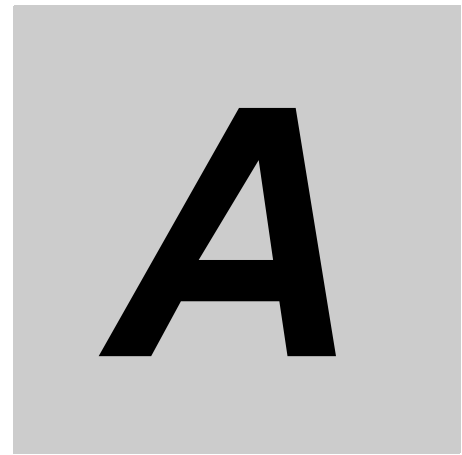

# General Specifications

A

This section contains hardware specifications, accessory and cable information, and product part numbering logic for MicroHAWK V320-F, V330-F, V420-F, and V430-F readers.

---

<b>A-1</b>	<b>Introduction</b>	<b>A-2</b>
<b>A-2</b>	<b>Grounding and Power</b>	<b>A-24</b>
<b>A-3</b>	<b>Accessories and Cables</b>	<b>A-26</b>
<b>A-4</b>	<b>Part Number Structure</b>	<b>A-65</b>

# A-1 General Specifications

## MicroHAWK V320-F

V320-F		V320-F□□□□03M-□□□	V320-F□□□□12M-□□□	V320-F□□□□50C-□□□
Symbologies *1	1D Symbologies	Code 39, Code 128, BC412, Interleaved 2 of 5, UPC/EAN, Codabar, Code 93, Pharmacode, PLANET, Postnet, Japanese Post, Australian Post, Royal Mail, Intelligent Mail, KIX		
	2D Symbologies	Data Matrix (ECC 0-200), QR Code, Micro QR Code, Aztec Code, DotCode		
	Stacked Symbologies	PDF417, MicroPDF417, GS1 Databar (Composite and Stacked)		
Reading Performance *2	Number of Reading Digits	No Upper Limit (depending on bar width and reading distance)		
	Aiming Light	Two Blue LEDs		
	Illumination	Inner LEDs: Four White and Four Red (Wavelength: 625 nm)		
		Outer LEDs:	None	None
	Reading Distance / Field of View	Refer to the <i>Field of View Charts</i> for detail.		
	Pitch Angle ( $\alpha$ ) *3	$\pm 30^\circ$		
	Skew Angle ( $\beta$ ) *3	$\pm 30^\circ$		
Tilt Angle ( $\gamma$ ) *3	$\pm 180^\circ$			
Image Capture	Focus	Fixed Focus (Wide = 5.2 mm, Medium = 7.7 mm, Narrow = 16 mm)		
	Resolution	752 (H) x 480 (V)	1280 (H) x 960 (V)	2592 (H) x 1944 (V)
	Color / Monochrome	Monochrome CMOS	Monochrome CMOS	Color CMOS
	Shutter	Global Shutter	Global Shutter	Rolling Shutter
	Frames per Second	60 fps	42 fps	5 fps
	Exposure	50 to 100,000 $\mu$ s		
Image Logging	FTP			
Trigger	External Trigger (Edge or Level), Communication Trigger (Ethernet, RS-232C)			
I/O Specifications	Input Signals	Trigger Input: 5-28 V rated (0.16 mA @ 5 VDC); Default: 3.3 V rated (0 mA @ 3.3 V)		
	Output Signals	One Signal (Strobe): 5 V TTL-compatible, can sink 10 mA and source 10 mA		
Communication	Connectivity	USB 2.0 Full-Speed (Ethernet over USB and HID), RS-232		
	Ethernet Specifications	100BASE-TX / 10BASE-T		
Indicator LEDs	PASS (Green), PWR (Green)			
Power Supply Voltage	5 VDC +/- 5%			
Current Consumption	450 mA at 5 VDC (max.)			
Environmental Immunity *4	Ambient Temperature Range	Operating: 0 to 40° C Storage: -50 to 75° C (No Icing or Condensation)		
	Ambient Humidity Range	Operating and Storage: 5% to 95% (Non-Condensing)		
	Ambient Atmosphere	No Corrosive Gases		
	Vibration Resistance (Destructive)	Oscillation Frequency: 10 to 150 Hz, Half Amplitude: 0.35 mm, Vibration Direction: X/Y/Z, Sweep Time: 8 minute/count, Sweep Count: 10 times		
	Shock Resistance (Destructive)	Impact Force: 150 m/s <sup>2</sup> , Test Direction: 6 directions, three times each (up/down, front/back, left/right)		
	Degree of Protection	IEC 60529 IP40		
Weight	Main Body Only	59 g		
	Packaging Weight	Approx. 166 g (including packing)		
Dimensions	Main Body Dimensions	52 (W) x 39 (D) x 24 (H) mm		
	Packaging Dimensions	170 (W) x 117 (D) x 86 (H) mm		
Accessories	ReadMeFirst, CE Compliance Sheet			
LED Safety Standard	IEC 62471-1: 2006 Risk-Exempt Group			
Safety Standards	EN 55024:2010, EN 55032:2015 + AC:2016 FCC Part 15, Subpart B (Class B) UL60950-1 BIS, RCM, KC, EAC, and BSMI			
Materials	Case	Aluminum Diecast, Alumite (Black)		
	Reading Window	Acrylic		
Software	WebLink			

\*1. These symbologies are supported based on Omron's read capability validation standard. Omron recommends that validation be performed for each application.  
 \*2. Unless otherwise specified, reading performance is defined with center of field of view, angle R= $\infty$ .



\*4. In an electrically noisy environment, use only the V430-F in combination with a noise filter cable (V430-W□F-□M) to ensure proper operation.

# MicroHAWK V330-F

V330-F		V330-F□□□□03M-□□□	V330-F□□□□12M-□□□	V330-F□□□□50C-□□□
Symbologies *1	1D Symbologies	Code 39, Code 128, BC412, Interleaved 2 of 5, UPC/EAN, Codabar, Code 93, PharmacoCode, PLANET, Postnet, Japanese Post, Australian Post, Royal Mail, Intelligent Mail, KIX		
	2D Symbologies	Data Matrix (ECC 0-200), QR Code, Micro QR Code, Aztec Code, DotCode		
	Stacked Symbologies	PDF417, MicroPDF417, GS1 Databar (Composite and Stacked)		
Reading Performance *2	Number of Reading Digits	No Upper Limit (depending on bar width and reading distance)		
	Aiming Light	Two Blue LEDs		
	Illumination	Inner LEDs: Four White and Four Red (Wavelength: 625 nm)		
		Outer LEDs:	None	None
	Reading Distance / Field of View	Refer to the <i>Field of View Charts</i> for detail.		
	Pitch Angle (α) *3	±30°		
	Skew Angle (β) *3	±30°		
Tilt Angle (γ) *3	±180°			
Image Capture	Focus	Fixed Focus (Wide = 5.2 mm, Medium = 7.7 mm, Narrow = 16 mm)		
	Resolution	752 (H) x 480 (V)	1280 (H) x 960 (V)	2592 (H) x 1944 (V)
	Color / Monochrome	Monochrome CMOS	Monochrome CMOS	Color CMOS
	Shutter	Global Shutter	Global Shutter	Rolling Shutter
	Frames per Second	60 fps	42 fps	5 fps
	Exposure	50 to 100,000 μs		
Image Logging	FTP			
Trigger	Communication Trigger (Ethernet)			
I/O Specifications	Input Signals	Ethernet		
	Output Signals	Ethernet		
Communication	Connectivity	Ethernet TCP/IP, EtherNet/IP, PROFINET		
	Ethernet Specifications	100BASE-TX / 10BASE-T		
Indicator LEDs	PASS (Green), PWR (Green)			
Power Supply Voltage	Source: 44-57 VDC IEEE802.3af POE			
Current Consumption	Max Current: 0.10A			
Environmental Immunity *4	Ambient Temperature Range	Operating: 0 to 40° C Storage: -50 to 75° C (No Icing or Condensation)		
	Ambient Humidity Range	Operating and Storage: 5% to 95% (Non-Condensing)		
	Ambient Atmosphere	No Corrosive Gases		
	Vibration Resistance (Destructive)	Oscillation Frequency: 10 to 150Hz, Half Amplitude: 0.35 mm, Vibration Direction: X/Y/Z, Sweep Time: 8 minute/count, Sweep Count: 10 times		
	Shock Resistance (Destructive)	Impact Force: 150 m/s <sup>2</sup> , Test Direction: 6 directions, three times each (up/down, front/back, left/right)		
	Degree of Protection	IEC 60529 IP40		
Weight	Main Body Only	72 g		
	Packaging Weight	Approx. 180 g (including packing)		
Dimensions	Main Body Dimensions	40 (W) x 63 (D) x 24 (H) mm		
	Packaging Dimensions	170 (W) x 117 (D) x 86 (H) mm		
Accessories	ReadMeFirst, CE Compliance Sheet			
LED Safety Standard	IEC 62471-1: 2006 Risk-Exempt Group			
Safety Standards	EN 55024:2010, EN 55032:2015 + AC:2016 FCC Part 15, Subpart B (Class B) UL60950-1 BIS, RCM, KC, EAC, and BSMI			
Materials	Case	Aluminum Diecast, Alumite (Black)		
	Reading Window	Acrylic		
Software	WebLink			

\*1. These symbologies are supported based on Omron's read capability validation standard. Omron recommends that validation be performed for each application.

\*2. Unless otherwise specified, reading performance is defined with center of field of view, angle R=∞.



\*4. In an electrically noisy environment, use only the V430-F in combination with a noise filter cable (V430-W□F-□M) to ensure proper operation.

A

## MicroHAWK V420-F

V420-F		V420-F□□□□03M-□□□	V420-F□□□□12M-□□□	V420-F□□□□50C-□□□
Symbolologies *1	1D Symbolologies	Code 39, Code 128, BC412, Interleaved 2 of 5, UPC/EAN, Codabar, Code 93, Pharmacode, PLANET, Postnet, Japanese Post, Australian Post, Royal Mail, Intelligent Mail, KIX		
	2D Symbolologies	Data Matrix (ECC 0-200), QR Code, Micro QR Code, Aztec Code, DotCode		
	Stacked Symbolologies	PDF417, MicroPDF417, GS1 Databar (Composite and Stacked)		
Reading Performance *2	Number of Reading Digits	No Upper Limit (depending on bar width and reading distance)		
	Aiming Light	Two Blue LEDs		
	Illumination	Inner LEDs: Four White and Four Red (Wavelength: 625 nm)		
		Outer LEDs:	8 Red or White	8 Red or White
	Reading Distance / Field of View	Refer to the <i>Field of View Charts</i> for detail.		
	Pitch Angle (α) *3	±30°		
	Skew Angle (β) *3	±30°		
Tilt Angle (γ) *3	±180°			
Image Capture	Focus	Liquid Lens Autofocus or Fixed Focus (Wide = 5.2 mm, Medium = 7.7 mm, Narrow = 16 mm, L = 16 mm)		
	Resolution	752 (H) x 480 (V)	1280 (H) x 960 (V)	2592 (H) x 1944 (V)
	Color / Monochrome	Monochrome CMOS	Monochrome CMOS	Color CMOS
	Shutter	Global Shutter	Global Shutter	Rolling Shutter
	Frames per Second	60 fps	42 fps	5 fps
	Exposure	50 to 100,000 μs		
Image Logging		FTP		
Trigger		External Trigger (Edge or Level), Communication Trigger (Ethernet, RS-232C)		
I/O Specifications	Input Signals	Trigger Input: 5-28 V rated (0.16 mA @ 5V DC); New Master: 5 to 28 V rated (0.16 mA @ 5 VDC); Default: 3.3 V rated (0 mA @ 3.3 V)		
	Output Signals	3 Signals : 5 V TTL-compatible, can sink 10 mA and source 10 mA		
Communication	Connectivity	RS-232C, USB 2.0 High Speed, Ethernet over USB/HID		
	Ethernet Specifications	100BASE-TX / 10BASE-T		
Indicator LEDs		PASS (Green), TRIG (Amber), MODE (Amber), LINK (Amber), FAIL (Red), PWR (Green)		
Power Supply Voltage		5 VDC +/- 5%		
Current Consumption		650 mA at 5 VDC (max.)		
Environmental Immunity *4	Ambient Temperature Range	Operating: 0 to 45° C Storage: -50 to 75°C (No Icing or Condensation)		
	Ambient Humidity Range	Operating and storage: 5% to 95% (Non-Condensing)		
	Ambient Atmosphere	No Corrosive Gases		
	Vibration Resistance (Destructive)	Sine Vibration: 10 Hz to 55 Hz, 0.35 mm displacement, 20 cycles/axis. Random Vibration: 20 Hz to 2000 Hz, 6.295 Grms, 30 min/axis		
	Shock Resistance (Destructive)	50G, 11 ms, sawtooth profile. 3X in each X, Y, Z axis		
	Degree of Protection	IEC 60529 IP54		
Weight	Main Body Only	120 g		
	Packaging Weight	Approx. 230 g (including packing)		
Dimensions	Main Body Dimensions	44.5 (W) × 38.1 (D) × 25.4 (H) mm		
	Packaging Dimensions	170 (W) × 117 (D) × 86 (H) mm		
Accessories		ReadMeFirst, CE Compliance Sheet		
LED Safety Standard		IEC 62471-1: 2006 Risk-Exempt Group		
Safety Standards		EN 55024:2010, EN 55032:2015 + AC:2016 FCC Part 15, Subpart B (Class B) UL60950-1 BIS, RCM, KC, EAC, and BSMI		
Materials	Case	Aluminum Diecast, Alumite (Black)		
	Reading Window	Acrylic		
Software		WebLink		

\*1. These symbolologies are supported based on Omron's read capability validation standard. Omron recommends that validation be performed for each application.

\*2. Unless otherwise specified, reading performance is defined with center of field of view, angle R=∞.

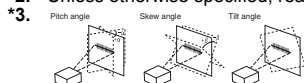

\*4. In an electrically noisy environment, use only the V430-F in combination with a noise filter cable (V430-W□F-□M) to ensure proper operation.

# MicroHAWK V430-F

V430-F		V430-F□□□□03M-□□□	V430-F□□□□12M-□□□	V430-F□□□□50C-□□□
Symbologies *1	1D Symbologies	Code 39, Code 128, BC412, Interleaved 2 of 5, UPC/EAN, Codabar, Code 93, Pharmacoce, PLANET, Postnet, Japanese Post, Australian Post, Royal Mail, Intelligent Mail, KIX		
	2D Symbologies	Data Matrix (ECC 0-200), QR Code, Micro QR Code, Aztec Code, DotCode		
	Stacked Symbologies	PDF417, MicroPDF417, GS1 Databar (Composite and Stacked)		
Reading Performance *2	Number of Reading Digits	No Upper Limit (depending on bar width and reading distance)		
	Aiming Light	Two Blue LEDs		
	Illumination	Inner LEDs: Four White and Four Red (Wavelength: 625 nm)		
		Outer LEDs: 8 Red or White	Outer LEDs: 8 Red or White; 24 Red or White for V430-F□□□□12M-R□□	Outer LEDs: 8 White
	Reading Distance / Field of View	Refer to the <i>Field of View Charts</i> for detail.		
	Pitch Angle (α) *3	±30°		
	Skew Angle (β) *3	±30°		
	Tilt Angle (γ) *3	±180°		
Image Capture	Focus	Liquid Lens Autofocus or Fixed Focus (Wide = 5.2 mm, Medium = 7.7 mm, Narrow = 16 mm, L = 16 mm)		
	Resolution	752 (H) x 480 (V)	1280 (H) x 960 (V)	2592 (H) x 1944 (V)
	Color / Monochrome	Monochrome CMOS	Monochrome CMOS	Color CMOS
	Shutter	Global Shutter	Global Shutter	Rolling Shutter
	Frames per Second	60 fps	42 fps	5 fps
	Exposure	50 to 100,000 μs		
Image Logging	FTP			
Trigger	External Trigger (Edge or Level), Communication Trigger (Ethernet, RS-232C)			
I/O Specifications	Input Signals	Trigger Input; New Master: Bi-Directional, Optoisolated, 4.5-28 V rated (10 mA @ 28 VDC)		
	Output Signals	3 Signals : Bi-Directional, Optoisolated, 1-28V rated, (ICE < 100 mA at 24VDC, current limited by user)		
Communication	Connectivity	RS-232C, Ethernet TCP/IP, EtherNet/IP, PROFINET		
	Ethernet Specifications	100BASE-TX / 10BASE-T		
Indicator LEDs	PASS (Green), TRIG (Amber), MODE (Amber), LINK (Amber), FAIL (Red), PWR (Green)			
Power Supply Voltage	DC24V (Ambient Voltage Range: DC10~30V) *5			
Current Consumption	0.18 A at 24 VDC (max.)			
Environmental Immunity *4	Ambient Temperature Range	Operating: 0 to 45° C Storage: -50 to 75°C (No Icing or Condensation)		
	Ambient Humidity Range	Operating and Storage: 5% to 95% (Non-Condensing)		
	Ambient Atmosphere	No Corrosive Gases		
	Vibration Resistance (Destructive)	Sine Vibration: 10 Hz to 55 Hz, 0.35 mm displacement, 20 cycles/axis. Random Vibration: 20 Hz to 2000 Hz, 6.295 Grms, 30 min/axis		
	Shock Resistance (Destructive)	50G, 11 ms, sawtooth profile. 3X in each X, Y, Z axis		
	Degree of Protection	IEC 60529 IP65 and IP67		
Weight	Main Body Only	Approx. 68 g		
	Packaging Weight	Approx. 174 g (including packing)		
Dimensions	Main Body Dimensions	44.5 (W) × 44.5 (D) × 25.4 (H) mm		
	Packaging Dimensions	170 (W) × 117 (D) × 86 (H) mm		
Accessories	ReadMeFirst, CE Compliance Sheet			
LED Safety Standard	IEC 62471-1: 2006 Risk-Exempt Group			
Safety Standards	EN 55024:2010, EN 55032:2015 + AC:2016 FCC Part 15, Subpart B (Class B) UL60950-1 BIS, RCM, KC, EAC, and BSMI			
Materials	Case	Aluminum Diecast, Alumite (Black)		
	Reading Window	Acrylic		
Software	WebLink			

\*1. These symbologies are supported based on Omron's read capability validation standard. Omron recommends that validation be performed for each application.

\*2. Unless otherwise specified, reading performance is defined with center of field of view, angle R=∞.

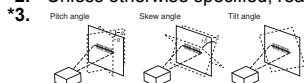

\*4. In an electrically noisy environment, use only the F430-F in combination with a noise filter cable (V430-W□F-□M) to ensure proper operation.

\*5. UL certification rating is DC24V. Maximum ripple is 200 mV p-p.

A

## MicroHAWK Cable Specifications

Item	V430-W8 <sub>00</sub> -_M	V430-W <sub>000</sub> F-_M	V430-WQ-_M	V430-WE <sub>00</sub> -_M
Cable Type	Robot cable	Robot cable. Overmolded filter must be protected from flexing	Robot cable	Robot cable
Connector Type	Straight LD: Right Angle Down LU: Right Angle Up	Straight LD: Right Angle Down LU: Right Angle Up	Straight	Straight LD: Right Angle Down LU: Right Angle Up
Category	I/O			Ethernet
Size	AWG24			AWG24
Outer Diameter	7.11mm			7.37mm
Min. Bending Radius	53mm			73.7mm
Usage Environment	Ambient Temperature Range	Operating: 0-45C Storage: -50 to 75C (No Icing or Condensation)		
	Ambient Humidity Range	5-95% (Non-Condensing)		
	Ambient Atmosphere	No Corrosive Gases		
	Vibration Tolerance	Oscillation Frequency: 10 to 150Hz, Half Amplitude: 0.35 mm, Vibration Direction: X/Y/Z, Sweep Time: 8 minute/count, Sweep Count: 10 times		
	Shock Resistance	Impact Force: 150 m/s <sup>2</sup> , Test Direction: 6 directions, three times each (up/down, front/back, left/right)		
Material	Connector Overmold: Thermoplastic Polyamide, Cable Jacket: Polyurethane			
Weight	V430-W8-3M: 259g V430-W8-5M: 422g V430-W8LD-3M: 253g V430-W8LU-3M: 253g	V430-WQF-1M: 79g V430-W8F-3M: 285g V430-W8F-5M: 447g V430-W8LDF-3M: 278g V430-W8LUF-3M: 278g	V430-WQ-1M: 109g V430-WQ-3M: 272g V430-WQ-5M: 351g	V430-WE-1M: 94g V430-WE-3M: 215g V430-WE-5M: 352g V430-WELD-3M: 218g V430-WELU-3M: 218g

Item	61-000151-01	
Cable Type	Static use cable	
Connector Type	Straight	
Category	I/O	
Size	AWG22	
Outer Diameter	5.82mm	
Min. Bending Radius	63.5mm	
Usage Environment	Ambient Temperature Range	Operating: 0-45C Storage: -50 to 75C (No Icing or Condensation)
	Ambient Humidity Range	5-95% (Non-Condensing)
	Ambient Atmosphere	No Corrosive Gases
	Vibration Tolerance	Oscillation Frequency: 10 to 150Hz, Half Amplitude: 0.35 mm, Vibration Direction: X/Y/Z, Sweep Time: 8 minute/count, Sweep Count: 10 times
	Shock Resistance	Impact Force: 150 m/s <sup>2</sup> , Test Direction: 6 directions, three times each (up/down, front/back, left/right)
Material	Connector Housing: Nylon, Cable Jacket: PVC	
Weight	67g	

### MicroHAWK Cable Specifications (continued)

Item	V430-WQR-3M	V430-WR-_M	V430-WQK-3M
Cable Type	Robot cable. "Y" must be produced from flexing	Robot cable	Robot cable (2M long section only). Protect "Y" from flexing.
Connector Type	Straight		
Category	I/O and RS232		Keyboard Wedge
Size	AWG24		
Outer Diameter	7.11mm		
Min. Bending Radius	53mm		
Usage Environment	Ambient Temperature Range	Operating: 0-45C Storage: -50 to 75C (No Icing or Condensation)	
	Ambient Humidity Range	5-95% (Non-Condensing)	
	Ambient Atmosphere	No Corrosive Gases	
	Vibration Tolerance	Oscillation Frequency: 10 to 150Hz, Half Amplitude: 0.35 mm, Vibration Direction: X/Y/Z, Sweep Time: 8 minute/count, Sweep Count: 10 times	
	Shock Resistance	Impact Force: 150 m/s <sup>2</sup> , Test Direction: 6 directions, three times each (up/down, front/back, left/right)	
Material	Connector Overmold: Thermoplastic Polyamide, Cable Jacket: Polyurethane		
Weight	273g	V430-WR-1M: 107g V430-WR-3M: 276g	270g

Item	V420-WUB-1M	V420-WUX-1M	V420-WRX-1M	V420-WU8X-1M	V420-WRU8X-1M
Cable Type	Static use cable.				
Connector Type	Straight				
Category	USB & USB/RS232 W/ External Power				
Size	AWG24			AWG26	
Outer Diameter	4.5mm	5mm		4.7mm	
Min. Bending Radius	45mm	4.8mm		47mm	
Usage Environment	Ambient Temperature Range	Operating: 0-45C Storage: -50 to 75C (No Icing or Condensation)			
	Ambient Humidity Range	5-95% (Non-Condensing)			
	Ambient Atmosphere	No Corrosive Gases			
	Vibration Tolerance	Oscillation Frequency: 10 to 150Hz, Half Amplitude: 0.35 mm, Vibration Direction: X/Y/Z, Sweep Time: 8 minute/count, Sweep Count: 10 times			
	Shock Resistance	Impact Force: 150 m/s <sup>2</sup> , Test Direction: 6 directions, three times each (up/down, front/back, left/right)			
Material	PVC	Connector Shell/Overmold: Thermoplastic UL94 V-0, Cable Jacket: PVC			
Weight	55g	55g	94g	125g	155g



### MicroHAWK Cable Specifications (continued)

Item		V320-W8□□-_M	V320-WR□□-_M
Cable Type		Static use cable.	
Connector Type		Straight	
Category		I/O, Power, Communication	
Size		AWG24	
Outer Diameter		5mm	
Min. Bending Radius		4.8mm	
Usage Environment	Ambient Temperature Range	Operating: 0-40C Storage: -50-75C (No Icing or Condensation)	
	Ambient Humidity Range	5-95% (Non-Condensing)	
	Ambient Atmosphere	No Corrosive Gases	
	Vibration Tolerance	Oscillation Frequency: 10 to 150Hz, Half Amplitude: 0.35 mm, Vibration Direction: X/Y/Z, Sweep Time: 8 minute/count, Sweep Count: 10 times	
Shock Resistance		Impact Force: 150 m/s <sup>2</sup> , Test Direction: 6 directions, three times each (up/down, front/back, left/right)	
Material		Connector Shell/Overmold: Thermoplastic UL94 V-0, Cable Jacket: PVC	
Weight		V320-W8-3M: 44g V320-W8LR-3M: 44g	V320-WRX-2M: 78g V320-WRXLR-2M: 78g V320-WR-1M: 60g V320-WRLR-1m: 60g

Item		V430-AF0	V430-AF1	V430-AF2	V430-AF3	V430-AF4	V430-AF5
Filter Type		Clear Window	Diffuser	Polarizer	Right Angle Mirror	YAG Laser	ESD Window Resistivity ≤ 1.0 X 10 <sup>9</sup> OHMS/SQ
Usage Environment	Ambient Temperature Range	Operating: 0-45C Storage: -50 to 75C (No Icing or Condensation)					
	Ambient Humidity Range	5-95% (Non-Condensing)					
	Ambient Atmosphere	No Corrosive Gases					
	Vibration Tolerance	Oscillation Frequency: 10 to 150Hz, Half Amplitude: 0.35 mm, Vibration Direction: X/Y/Z, Sweep Time: 8 minute/count, Sweep Count: 10 times			Note 1	Oscillation Frequency: 10 to 150Hz, Half Amplitude: 0.35 mm, Vibration Direction: X/Y/Z, Sweep Time: 8 minute/count, Sweep Count: 10 times	
Shock Resistance	Impact Force: 150 m/s <sup>2</sup> , Test Direction: 6 directions, three times each (up/down, front/back, left/right)			Impact Force: 150 m/s <sup>2</sup> , Test Direction: 6 directions, three times each (up/down, front/back, left/right)			
Material		Acrylic	Polyester	Polymer Film	Bracket: Aluminum Mirror: Soda Lime Glass	Acrylic	Acrylic
Weight		3.4g	3.6g	3.6g	36.3g	8g	3.4g

Note 1: Test data not available. Customer to evaluate for given installation.



## MicroHAWK Accessory Specifications

Item	V430-AF6	V430-AF7	V430-AF0R	V430-AF1R	V430-AF2R	V330-AF1	V330-AF2
Filter Type	Red Light	Blue Light	Clear Window	Diffuser	Polarizer	Diffuser	Polarizer
Usage Environment	Operating: 0-45C Storage: -50 to 75C (No Icing or Condensation)					Operating: 0-40C Storage: -50 to 75C (No Icing or Condensation)	
	Ambient Humidity Range: 5-95% (Non-Condensing)						
	Ambient Atmosphere: No Corrosive Gases						
	Vibration Tolerance: Oscillation Frequency: 10 to 150Hz, Half Amplitude: 0.35 mm, Vibration Direction: X/Y/Z, Sweep Time: 8 minute/count, Sweep Count: 10 times						
	Shock Resistance: Impact Force: 150 m/s <sup>2</sup> , Test Direction: 6 directions, three times each (up/down, front/back, left/right)						
Material	Acrylic	Acrylic	Acrylic	Acrylic	Polymer Film	Polyester	Polymer Film
Weight	3.4g	3.4g	10g	10g	10g	0.12g	0.25g

Item	V430-ALR	V430-ALW	V430-ALB	V430-ALI	V430-ALRR	V430-ALWR	V430-ALBR	V430-ALIR
Light Type	Red	White	Blue	IR	Red	White	Blue	IR
Usage Environment	Operating: 0-45C Storage: -50 to 75C (No Icing or Condensation)							
	Ambient Humidity Range: 5-95% (Non-Condensing)							
	Ambient Atmosphere: No Corrosive Gases							
	Vibration Tolerance: Oscillation Frequency: 10 to 150Hz, Half Amplitude: 0.35 mm, Vibration Direction: X/Y/Z,							
	Shock Resistance: Impact Force: 150 m/s <sup>2</sup> , Test Direction: 6 directions, three times each (up/down,							
Weight	1g	1g	1g	1g	3g	3g	3g	3g

Item	V430-AM0	V430-AM1	V430-AM2	V430-AM3	V430-AM4	V430-AM5	V430-AM6	V430-AM7
Mount Type	L Bracket	1/4"-20 Mount	4" Ram Mount	APG Mount	Isolation Mount	Adapter MS4 to F/V4X0	Bracket, Smart Ring to F/V4X0	Bracket, QX-Hawk to F/V4X0, Isolated
Usage Environment	Operating: 0-45C Storage: -50 to 75C (No Icing or Condensation)							
	Ambient Humidity Range: 5-95% (Non-Condensing)							
	Ambient Atmosphere: No Corrosive Gases							
	Vibration Tolerance: Note 1							
	Shock Tolerance: Note 1							
Material	Stainless Steel w/ Stainless Steel Fasteners	Aluminum w/ Stainless Steel Fasteners	Aluminum, Rubber w/ Stainless Steel Fasteners	Stainless Steel w/ Stainless Steel Fasteners	Nylon	Aluminum w/ Stainless Steel Fasteners	Aluminum w/ Stainless Steel Fasteners	Nylon w/ Nylon and Stainless Steel Fasteners
Weight	139g	20g	113g	232g	2g	20g	27g	30g

Note 1: Test data not available. Customer to evaluate for given installation.

### MicroHAWK Accessory Specifications (continued)

Item	97-9000006-01	97-000011-02	97-000012-01	V330-AP1
Compatible models	V420/F420/V320/F320		V430/F430	V330/F330
Power Supply Type	5V Power Supply, 5.5mm x 2.5mm Barrel Connector	5V Power Supply, 2 Pole Locking DIN Connector	5V Power Supply, 12 Pole M12 Socket	56V Single Port POE Injector (IEEE802.3at Compliant)
AC Plug Shape	A/C/G	B/E	B/E	—
Input Voltage	AC100V-240V			
Output Voltage	DC5V	DC5V	DC24V	DC56V
Maximum Output Current	2A	4A	2.1A	0.5A
Usage Environment	Ambient Temperature Range	Operating: 0-50C Storage: -10-55C (No Icing or Condensation)	Operating: 0-40C Storage: -20-80C (No Icing or Condensation)	Operating: 0-40C Storage: -20-80C (No Icing or Condensation)
	Ambient Humidity Range	5-90%	20-80%	20-80%
	Ambient Atmosphere	No Corrosive Gases		
	Vibration Tolerance	Note 1		
	Shock Tolerance	Note 1		
Power Supply Manufacturer	Mega Electronics Inc.			Phihong
Safety Standards	UL, CCC, CE, RCM, PSE, KC, EAC	UL, CCC, CE, RCM, PSE, KC, EAC, BSMI	UL, CCC, CE, RCM, PSE, KC, EAC, BSMI	UL, CB, CCC, BSMI, CU (EAC), IRAM (TUV-s), CE, RCM, NOM/NYCE, PSB, KC+KCC, EAC
Weight	100g	170g	258g	234g

Item	V420-AC0	V420-AC1	V420-AC2
Contents	Power Supply	97-9000006-01	97-000011-02
	Cable	V420-WRX-1M	V420-WUX-1M
Weight	349g	329g	851g

Note 1: Test data not available. Customer to evaluate for given installation.

## A-1-1 MicroHAWK V430-F Field of View and Installation Distance

Field of view / Installation distance

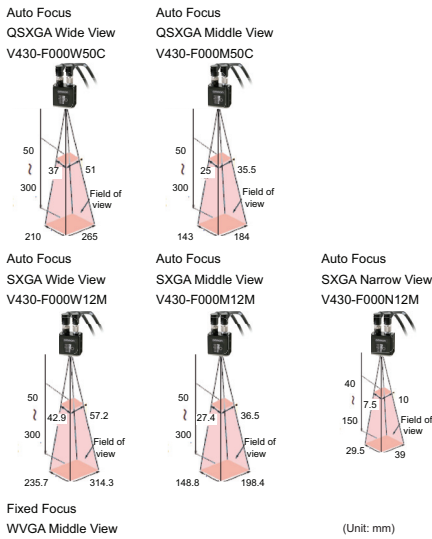

Model	Minimum 2D Element Size (mm)*
V430-F000W50C	0.13
V430-F000M50C	0.09
V430-F000W12M	0.13
V430-F000M12M	0.09
V430-F000N12M	0.05
V430-F050M03M	0.13
V430-F081M03M	0.19
V430-F102M03M	0.26

V430-F000W50C: WD = 50 mm, Field of view = 51 × 37 mm  
 V430-F000M50C: WD = 50 mm, Field of view = 35.5 × 25 mm  
 V430-F000W12M: WD = 50 mm, Field of view = 57.2 × 42.9 mm  
 V430-F000M12M: WD = 50 mm, Field of view = 36.5 × 27.4 mm  
 V430-F000N12M: WD = 40 mm, Field of view = 10 × 7.5 mm  
 The minimum size is what could be read in ideal conditions.

	V430-F102M03M	V430-F081M03M	V430-F050M03M
<b>Field of View</b>	65 mm	49 mm	35 mm
<b>Installation Distance</b>	102 mm	81 mm	50 mm

The LEDs indicate the following conditions:

- **PWR (Green):** On when power is on.
- **FAIL (Red):** On when No Read (Off in Read Cycle).
- **LINK (Orange):** On when communication is established.
- **MODE (Orange):** On in Read Cycle.
- **TRIG (Orange):** On when the TRIG signal (in parallel) is turned on.
- **PASS (Green):** On in Good Read (Off in Read Cycle).

**Note:** When the Read Rate mode (command) is set, the LED indicator will be lit longer as the Read Rate increases. In Bar Code Configuration mode, the LED indicators flash in order.

## A-1-2 Lighting Mode Table

Lighting Mode	Inner LEDs	Outer LEDs	Off	On	Strobe	Power Strobe Inner LEDs	Power Strobe Outer LEDs	External Strobe
Engine USB Power	Yes	No	Yes	Yes	Yes	No	N/A	No
Engine External Power	Yes	No	Yes	Yes	Yes	No	N/A	Yes
V320-F / F320-F USB Power	Yes	No	Yes	Yes	Yes	No	N/A	Yes
V320-F / F320-F External Power	Yes	No	Yes	Yes	Yes	No	N/A	Yes
V330-F / F330-F	Yes	No	Yes	Yes	Yes	No	N/A	No
V420-F / F420-F USB Power	Yes	Yes	Yes	Yes	Yes	No	No	Yes
V420-F / F420-F External Power	Yes	Yes	Yes	Yes	Yes	No	Yes	Yes
V430-F / F430-F (Standard Type)	Yes	Yes	Yes	Yes	Yes	No	Yes	Yes
V430-F / F430-F (Ring Type)	N/A	Yes	Yes	Yes	Yes	No	Yes	Yes

### A-1-3 Field of View Charts

#### Fixed Focus Field of View (mm) - Wide Lens

Distance (mm)	0.3 MP		1.2 MP		5 MP	
	Width	Height	Width	Height	Width	Height
50	49	32	53	39	50	38
64	62	39	66	49	63	47
81	76	49	81	61	78	58
102	95	60	101	75	96	72
133	121	78	129	97	124	92
190	171	109	182	136	174	130
300	266	170	283	213	271	202

#### Fixed Focus Field of View (mm) - Medium Lens

Distance (mm)	0.3 MP		1.2 MP		5 MP	
	Width	Height	Width	Height	Width	Height
50	34	22	36	27	35	26
64	43	27	45	34	43	32
81	53	34	56	42	54	40
102	66	42	70	52	67	50
133	84	54	90	67	86	64
190	119	76	126	95	121	90
300	185	118	196	147	188	140

#### Fixed Focus Field of View (mm) - Narrow Lens

Distance (mm)	1.2 MP	
	Width	Height
400	118	88

### Autofocus Field of View (mm) - Wide Lens

Distance (mm)	0.3 MP		1.2 MP		5 MP	
	Width	Height	Width	Height	Width	Height
50	51	33	55	41	52	39
100	97	62	103	77	98	73
150	142	90	151	113	144	107
200	187	119	199	149	190	142
250	232	148	247	185	236	176
300	277	177	295	221	282	210

### Autofocus Field of View (mm) - Medium Lens

Distance (mm)	0.3 MP		1.2 MP		5 MP	
	Width	Height	Width	Height	Width	Height
50	33	21	36	27	34	25
100	63	40	67	50	64	48
150	92	59	98	73	94	70
200	121	77	129	97	123	92
250	151	96	160	120	153	114
300	180	115	191	144	183	136

### Autofocus Field of View (mm) - Narrow Lens

Distance (mm)	1.2 MP	
	Width	Height
50	16	12
100	31	23
150	45	34

### Long Range Autofocus Field of View (mm)

Distance (mm)	1.2 MP	
	Width	Height
75	24	18
100	31	23
200	60	45
300	89	67
400	118	88
500	147	110
600	176	132
700	204	153
800	233	175
900	262	197
1000	291	218
1200	349	262
1300	378	283
1400	407	305
1500	436	327

A

## A-1-4 Readability Tables

The readability tables on the following pages are designed to help users choose the best read-distance, sensor, and lens combination to read their particular code size and code type successfully.

The readability tables show the calculated PPE (pixels per element) for a range of typical code sizes at all the MicroHAWK Fixed Focus distances with the Wide, Medium, Narrow and Long Range lens as well as with the 0.3MP, 1.2MP, and 5MP sensors.

PPE is defined as the following for 1D and 2D codes:

- PPE for 1D codes is the number of pixels across the thinnest bar in the barcode.
- PPE for 2D codes is the number of pixels across a single code cell.

The tables show a color code for readability based on DPM marks (Direct Part Marks) where red means not likely to read, and green means that it should read. The tables also show a range of colors between red and green, while showing the zone where read rates may be acceptable for high-contrast, well-printed labels and can be considered. See the 1D and 2D Code Readability Guidelines below for Minimum and Preferred PPE for both DPM marks and high-contrast labels.



### 1D Code Readability Guidelines

---

#### ● High-Contrast Labels

- 1.5 pixels per thin bar is suggested minimum;
- 2 pixels or more per thin bar is preferred.

#### ● Direct Part Marks

- 2 pixels per thin bar is suggested minimum;
- 2.5 pixels or more per thin bar is preferred.

### 2D Code Readability Guidelines

---



#### ● High-Contrast Labels

- 2.5 – 2.75 pixels per 2D cell is suggested minimum;
- 3.5 – 5 pixels per 2D cell is preferred.

#### ● Direct Part Marks

- 3.25 pixels per 2D Cell is suggested minimum;
- 4 – 6 pixels per 2D Cell is preferred.

## Readability Table – 0.3 Megapixel

 = Maximum Readability  
 = Minimum Readability

0.3 Megapixel – Pixels Per Element / Readability Chart																	
Minimum Element Size	Readability of 1D Code at Distance (mm)								Lens	Readability of 2D Code at Distance (mm)							
	50	64	81	102	133	190	300	400		50	64	81	102	133	190	300	400
2 mil	0.7	0.6	0.5	0.4	0.3	0.2	0.1	0.1	Wide Lens	0.7	0.6	0.5	0.4	0.3	0.2	0.1	0.1
2.5 mil	0.9	0.7	0.6	0.5	0.4	0.3	0.2	0.1		0.9	0.7	0.6	0.5	0.4	0.3	0.2	0.1
3.3 mil	1.2	1.0	0.8	0.6	0.5	0.4	0.2	0.2		1.2	1.0	0.8	0.6	0.5	0.4	0.2	0.2
5 mil	1.9	1.5	1.2	1.0	0.8	0.5	0.3	0.3		1.9	1.5	1.2	1.0	0.8	0.5	0.3	0.3
7.5 mil	2.8	2.2	1.8	1.5	1.1	0.8	0.5	0.4		2.8	2.2	1.8	1.5	1.1	0.8	0.5	0.4
10 mil	3.7	3.0	2.4	1.9	1.5	1.1	0.7	0.5		3.7	3.0	2.4	1.9	1.5	1.1	0.7	0.5
15 mil	5.6	4.5	3.6	2.9	2.3	1.6	1.0	0.8		5.6	4.5	3.6	2.9	2.3	1.6	1.0	0.8
20 mil	7.4	6.0	4.8	3.9	3.0	2.1	1.4	1.0		7.4	6.0	4.8	3.9	3.0	2.1	1.4	1.0
30 mil	11.1	8.9	7.2	5.8	4.5	3.2	2.1	1.6		11.1	8.9	7.2	5.8	4.5	3.2	2.1	1.6
40 mil	14.9	11.9	9.6	7.8	6.0	4.3	2.8	2.1		14.9	11.9	9.6	7.8	6.0	4.3	2.8	2.1
2 mil	1.2	1.0	0.8	0.6	0.5	0.3	0.2	0.2	Medium Lens	1.2	1.0	0.8	0.6	0.5	0.3	0.2	0.2
2.5 mil	1.5	1.2	1.0	0.8	0.6	0.4	0.3	0.2		1.5	1.2	1.0	0.8	0.6	0.4	0.3	0.2
3.3 mil	2.0	1.6	1.3	1.0	0.8	0.6	0.4	0.3		2.0	1.6	1.3	1.0	0.8	0.6	0.4	0.3
5 mil	3.0	2.4	1.9	1.6	1.2	0.9	0.6	0.4		3.0	2.4	1.9	1.6	1.2	0.9	0.6	0.4
7.5 mil	4.5	3.6	2.9	2.3	1.8	1.3	0.8	0.6		4.5	3.6	2.9	2.3	1.8	1.3	0.8	0.6
10 mil	5.9	4.8	3.8	3.1	2.4	1.7	1.1	0.8		5.9	4.8	3.8	3.1	2.4	1.7	1.1	0.8
15 mil	8.9	7.2	5.8	4.7	3.6	2.6	1.7	1.2		8.9	7.2	5.8	4.7	3.6	2.6	1.7	1.2
20 mil	11.9	9.5	7.7	6.2	4.8	3.4	2.2	1.7		11.9	9.5	7.7	6.2	4.8	3.4	2.2	1.7
30 mil	17.8	14.3	11.5	9.3	7.3	5.2	3.3	2.5		17.8	14.3	11.5	9.3	7.3	5.2	3.3	2.5
40 mil	23.8	19.1	15.4	12.4	9.7	6.9	4.4	3.3		23.8	19.1	15.4	12.4	9.7	6.9	4.4	3.3
2 mil	2.5	2.0	1.6	1.3	1.0	0.7	0.5	0.3	Narrow Lens	2.5	2.0	1.6	1.3	1.0	0.7	0.5	0.3
2.5 mil	3.1	2.5	2.0	1.6	1.3	0.9	0.6	0.4		3.1	2.5	2.0	1.6	1.3	0.9	0.6	0.4
3.3 mil	4.1	3.3	2.6	2.1	1.7	1.2	0.8	0.6		4.1	3.3	2.6	2.1	1.7	1.2	0.8	0.6
5 mil	6.2	4.9	4.0	3.2	2.5	1.8	1.1	0.9		6.2	4.9	4.0	3.2	2.5	1.8	1.1	0.9
7.5 mil	9.2	7.4	6.0	4.8	3.8	2.7	1.7	1.3		9.2	7.4	6.0	4.8	3.8	2.7	1.7	1.3
10 mil	12.3	9.9	8.0	6.4	5.0	3.6	2.3	1.7		12.3	9.9	8.0	6.4	5.0	3.6	2.3	1.7
15 mil	18.5	14.8	12.0	9.7	7.5	5.4	3.4	2.6		18.5	14.8	12.0	9.7	7.5	5.4	3.4	2.6
20 mil	24.7	19.8	16.0	12.9	10.0	7.1	4.6	3.5		24.7	19.8	16.0	12.9	10.0	7.1	4.6	3.5
30 mil	37.0	29.7	24.0	19.3	15.1	10.7	6.9	5.2		37.0	29.7	24.0	19.3	15.1	10.7	6.9	5.2
40 mil	49.3	39.6	31.9	25.8	20.1	14.3	9.2	6.9		49.3	39.6	31.9	25.8	20.1	14.3	9.2	6.9

A

## Readability Table – 1.2 Megapixel

1.2 Megapixel – Pixels Per Element / Readability Chart																	
Minimum Element Size	Readability of 1D Code at Distance (mm)								Lens	Readability of 2D Code at Distance (mm)							
	50	64	81	102	133	190	300	400		50	64	81	102	133	190	300	400
2 mil	1.2	1.0	0.8	0.6	0.5	0.4	0.2	0.2	Wide Lens	1.2	1.0	0.8	0.6	0.5	0.4	0.2	0.2
2.5 mil	1.5	1.2	1.0	0.8	0.6	0.4	0.3	0.2		1.5	1.2	1.0	0.8	0.6	0.4	0.3	0.2
3.3 mil	2.0	1.6	1.3	1.1	0.8	0.6	0.4	0.3		2.0	1.6	1.3	1.1	0.8	0.6	0.4	0.3
5 mil	3.1	2.5	2.0	1.6	1.3	0.9	0.6	0.4		3.1	2.5	2.0	1.6	1.3	0.9	0.6	0.4
7.5 mil	4.6	3.7	3.0	2.4	1.9	1.3	0.9	0.6		4.6	3.7	3.0	2.4	1.9	1.3	0.9	0.6
10 mil	6.2	5.0	4.0	3.2	2.5	1.8	1.1	0.9		6.2	5.0	4.0	3.2	2.5	1.8	1.1	0.9
15 mil	9.3	7.4	6.0	4.8	3.8	2.7	1.7	1.3		9.3	7.4	6.0	4.8	3.8	2.7	1.7	1.3
20 mil	12.4	9.9	8.0	6.5	5.0	3.6	2.3	1.7		12.4	9.9	8.0	6.5	5.0	3.6	2.3	1.7
30 mil	18.5	14.9	12.0	9.7	7.5	5.4	3.4	2.6		18.5	14.9	12.0	9.7	7.5	5.4	3.4	2.6
40 mil	24.7	19.8	16.0	12.9	10.1	7.2	4.6	3.5		24.7	19.8	16.0	12.9	10.1	7.2	4.6	3.5
2 mil	1.8	1.4	1.2	0.9	0.7	0.5	0.3	0.2	Medium Lens	1.8	1.4	1.2	0.9	0.7	0.5	0.3	0.2
2.5 mil	2.2	1.8	1.4	1.2	0.9	0.6	0.4	0.3		2.2	1.8	1.4	1.2	0.9	0.6	0.4	0.3
3.3 mil	2.9	2.4	1.9	1.5	1.2	0.9	0.5	0.4		2.9	2.4	1.9	1.5	1.2	0.9	0.5	0.4
5 mil	4.5	3.6	2.9	2.3	1.8	1.3	0.8	0.6		4.5	3.6	2.9	2.3	1.8	1.3	0.8	0.6
7.5 mil	6.7	5.4	4.3	3.5	2.7	1.9	1.2	0.9		6.7	5.4	4.3	3.5	2.7	1.9	1.2	0.9
10 mil	8.9	7.2	5.8	4.7	3.6	2.6	1.7	1.2		8.9	7.2	5.8	4.7	3.6	2.6	1.7	1.2
15 mil	13.4	10.7	8.7	7.0	5.4	3.9	2.5	1.9		13.4	10.7	8.7	7.0	5.4	3.9	2.5	1.9
20 mil	17.8	14.3	11.5	9.3	7.3	5.2	3.3	2.5		17.8	14.3	11.5	9.3	7.3	5.2	3.3	2.5
30 mil	26.7	21.5	17.3	14.0	10.9	7.7	5.0	3.7		26.7	21.5	17.3	14.0	10.9	7.7	5.0	3.7
40 mil	35.6	28.6	23.1	18.6	14.5	10.3	6.6	5.0		35.6	28.6	23.1	18.6	14.5	10.3	6.6	5.0
2 mil	3.9	3.2	2.6	2.1	1.6	1.1	0.7	0.6	Narrow Lens	3.9	3.2	2.6	2.1	1.6	1.1	0.7	0.6
2.5 mil	4.9	4.0	3.2	2.6	2.0	1.4	0.9	0.7		4.9	4.0	3.2	2.6	2.0	1.4	0.9	0.7
3.3 mil	6.5	5.2	4.2	3.4	2.7	1.9	1.2	0.9		6.5	5.2	4.2	3.4	2.7	1.9	1.2	0.9
5 mil	9.9	7.9	6.4	5.2	4.0	2.9	1.8	1.4		9.9	7.9	6.4	5.2	4.0	2.9	1.8	1.4
7.5 mil	14.8	11.9	9.6	7.7	6.0	4.3	2.7	2.1		14.8	11.9	9.6	7.7	6.0	4.3	2.7	2.1
10 mil	19.7	15.8	12.8	10.3	8.0	5.7	3.7	2.8		19.7	15.8	12.8	10.3	8.0	5.7	3.7	2.8
15 mil	29.6	23.8	19.2	15.5	12.0	8.6	5.5	4.1		29.6	23.8	19.2	15.5	12.0	8.6	5.5	4.1
20 mil	39.5	31.7	25.6	20.6	16.1	11.4	7.3	5.5		39.5	31.7	25.6	20.6	16.1	11.4	7.3	5.5
30 mil	59.2	47.5	38.3	30.9	24.1	17.1	11.0	8.3		59.2	47.5	38.3	30.9	24.1	17.1	11.0	8.3
40 mil	78.9	63.3	51.1	41.3	32.1	22.8	14.6	11.1		78.9	63.3	51.1	41.3	32.1	22.8	14.6	11.1



## Readability Table – 5 Megapixel

5 Megapixel – Pixels Per Element / Readability Chart																	
Minimum Element Size	Readability of 1D Code at Distance (mm)								Lens	Readability of 2D Code at Distance (mm)							
	50	64	81	102	133	190	300	400		50	64	81	102	133	190	300	400
2 mil	1.7	1.4	1.1	0.9	0.7	0.5	0.3	0.2	Wide Lens	1.7	1.4	1.1	0.9	0.7	0.5	0.3	0.2
2.5 mil	2.2	1.7	1.4	1.1	0.9	0.6	0.4	0.3		2.2	1.7	1.4	1.1	0.9	0.6	0.4	0.3
3.3 mil	2.8	2.3	1.8	1.5	1.2	0.8	0.5	0.4		2.8	2.3	1.8	1.5	1.2	0.8	0.5	0.4
5 mil	4.3	3.5	2.8	2.3	1.8	1.2	0.8	0.6		4.3	3.5	2.8	2.3	1.8	1.2	0.8	0.6
7.5 mil	6.5	5.2	4.2	3.4	2.6	1.9	1.2	0.9		6.5	5.2	4.2	3.4	2.6	1.9	1.2	0.9
10 mil	8.6	6.9	5.6	4.5	3.5	2.5	1.6	1.2		8.6	6.9	5.6	4.5	3.5	2.5	1.6	1.2
15 mil	12.9	10.4	8.4	6.8	5.3	3.7	2.4	1.8		12.9	10.4	8.4	6.8	5.3	3.7	2.4	1.8
20 mil	17.3	13.9	11.2	9.0	7.0	5.0	3.2	2.4		17.3	13.9	11.2	9.0	7.0	5.0	3.2	2.4
30 mil	25.9	20.8	16.8	13.5	10.5	7.5	4.8	3.6		25.9	20.8	16.8	13.5	10.5	7.5	4.8	3.6
40 mil	34.5	27.7	22.4	18.1	14.1	10.0	6.4	4.8		34.5	27.7	22.4	18.1	14.1	10.0	6.4	4.8
2 mil	2.5	2.0	1.6	1.3	1.0	0.7	0.5	0.3	Medium Lens	2.5	2.0	1.6	1.3	1.0	0.7	0.5	0.3
2.5 mil	3.1	2.5	2.0	1.6	1.3	0.9	0.6	0.4		3.1	2.5	2.0	1.6	1.3	0.9	0.6	0.4
3.3 mil	4.1	3.3	2.7	2.1	1.7	1.2	0.8	0.6		4.1	3.3	2.7	2.1	1.7	1.2	0.8	0.6
5 mil	6.2	5.0	4.0	3.3	2.5	1.8	1.2	0.9		6.2	5.0	4.0	3.3	2.5	1.8	1.2	0.9
7.5 mil	9.3	7.5	6.0	4.9	3.8	2.7	1.7	1.3		9.3	7.5	6.0	4.9	3.8	2.7	1.7	1.3
10 mil	12.5	10.0	8.1	6.5	5.1	3.6	2.3	1.7		12.5	10.0	8.1	6.5	5.1	3.6	2.3	1.7
15 mil	18.7	15.0	12.1	9.8	7.6	5.4	3.5	2.6		18.7	15.0	12.1	9.8	7.6	5.4	3.5	2.6
20 mil	24.9	20.0	16.1	13.0	10.1	7.2	4.6	3.5		24.9	20.0	16.1	13.0	10.1	7.2	4.6	3.5
30 mil	37.4	30.0	24.2	19.5	15.2	10.8	6.9	5.2		37.4	30.0	24.2	19.5	15.2	10.8	6.9	5.2
40 mil	49.8	40.0	32.3	26.0	20.3	14.4	9.2	7.0		49.8	40.0	32.3	26.0	20.3	14.4	9.2	7.0
2 mil	5.5	4.4	3.6	2.9	2.2	1.6	1.0	0.8	Narrow Lens	5.5	4.4	3.6	2.9	2.2	1.6	1.0	0.8
2.5 mil	6.9	5.5	4.5	3.6	2.8	2.0	1.3	1.0		6.9	5.5	4.5	3.6	2.8	2.0	1.3	1.0
3.3 mil	9.1	7.3	5.9	4.8	3.7	2.6	1.7	1.3		9.1	7.3	5.9	4.8	3.7	2.6	1.7	1.3
5 mil	13.8	11.1	8.9	7.2	5.6	4.0	2.6	1.9		13.8	11.1	8.9	7.2	5.6	4.0	2.6	1.9
7.5 mil	20.7	16.6	13.4	10.8	8.4	6.0	3.8	2.9		20.7	16.6	13.4	10.8	8.4	6.0	3.8	2.9
10 mil	27.6	22.1	17.8	14.4	11.2	8.0	5.1	3.9		27.6	22.1	17.8	14.4	11.2	8.0	5.1	3.9
15 mil	41.3	33.2	26.8	21.6	16.8	12.0	7.7	5.8		41.3	33.2	26.8	21.6	16.8	12.0	7.7	5.8
20 mil	55.1	44.2	35.7	28.8	22.4	15.9	10.2	7.7		55.1	44.2	35.7	28.8	22.4	15.9	10.2	7.7
30 mil	82.7	66.4	53.5	43.2	33.7	23.9	15.3	11.6		82.7	66.4	53.5	43.2	33.7	23.9	15.3	11.6
40 mil	110.2	88.5	71.4	57.6	44.9	31.9	20.5	15.4		110.2	88.5	71.4	57.6	44.9	31.9	20.5	15.4

A

## Readability Table – Long Range

Long Range readability is shown out to 1,500 even though Autofocus is only specified out to 1,160. At the longest focus distance, the lens has a very deep depth of field. Large codes can actually be read beyond 2,000 mm.

Long Range 1.2 MP - Pixels Per Element/Readability Chart															
Readability of 1D Code at Distance (mm)															
Min Element Size	100	200	300	400	500	600	700	800	900	1000	1100	1200	1300	1400	1500
2 mil	2.10	1.09	0.73	0.55	0.44	0.37	0.32	0.28	0.25	0.22	0.20	0.19	0.17	0.16	0.15
2.5 mil	2.63	1.36	0.92	0.69	0.55	0.46	0.40	0.35	0.31	0.28	0.25	0.23	0.22	0.20	0.19
3.3 mil	3.47	1.79	1.21	0.91	0.73	0.61	0.52	0.46	0.41	0.37	0.34	0.31	0.28	0.26	0.25
5 mil	5.25	2.72	1.83	1.38	1.11	0.93	0.80	0.70	0.62	0.56	0.51	0.47	0.43	0.40	0.37
7.5 mil	7.88	4.07	2.75	2.07	1.66	1.39	1.19	1.04	0.93	0.84	0.76	0.70	0.65	0.60	0.56
10 mil	10.51	5.43	3.66	2.76	2.22	1.85	1.59	1.39	1.24	1.12	1.02	0.93	0.86	0.80	0.75
15 mil	15.76	8.15	5.49	4.14	3.33	2.78	2.39	2.09	1.86	1.67	1.52	1.40	1.29	1.20	1.12
20 mil	21.02	10.86	7.32	5.53	4.44	3.70	3.18	2.79	2.48	2.23	2.03	1.86	1.72	1.60	1.49
30 mil	31.52	16.30	10.99	8.29	6.65	5.56	4.77	4.18	3.72	3.35	3.05	2.79	2.58	2.40	2.24
40 mil	42.03	21.73	14.65	11.05	8.87	7.41	6.36	5.57	4.96	4.47	4.06	3.73	3.44	3.20	2.98

Readability of 2D Code at Distance (mm)															
Min Element Size	100	200	300	400	500	600	700	800	900	1000	1100	1200	1300	1400	1500
2 mil	2.10	1.09	0.73	0.55	0.44	0.37	0.32	0.28	0.25	0.22	0.20	0.19	0.17	0.16	0.15
2.5 mil	2.63	1.36	0.92	0.69	0.55	0.46	0.40	0.35	0.31	0.28	0.25	0.23	0.22	0.20	0.19
3.3 mil	3.47	1.79	1.21	0.91	0.73	0.61	0.52	0.46	0.41	0.37	0.34	0.31	0.28	0.26	0.25
5 mil	5.25	2.72	1.83	1.38	1.11	0.93	0.80	0.70	0.62	0.56	0.51	0.47	0.43	0.40	0.37
7.5 mil	7.88	4.07	2.75	2.07	1.66	1.39	1.19	1.04	0.93	0.84	0.76	0.70	0.65	0.60	0.56
10 mil	10.51	5.43	3.66	2.76	2.22	1.85	1.59	1.39	1.24	1.12	1.02	0.93	0.86	0.80	0.75
15 mil	15.76	8.15	5.49	4.14	3.33	2.78	2.39	2.09	1.86	1.67	1.52	1.40	1.29	1.20	1.12
20 mil	21.02	10.86	7.32	5.53	4.44	3.70	3.18	2.79	2.48	2.23	2.03	1.86	1.72	1.60	1.49
30 mil	31.52	16.30	10.99	8.29	6.65	5.56	4.77	4.18	3.72	3.35	3.05	2.79	2.58	2.40	2.24
40 mil	42.03	21.73	14.65	11.05	8.87	7.41	6.36	5.57	4.96	4.47	4.06	3.73	3.44	3.20	2.98

## Reader Dimensions

Dimensions: mm [in.]

### A-1-5 MicroHAWK V320-F Front

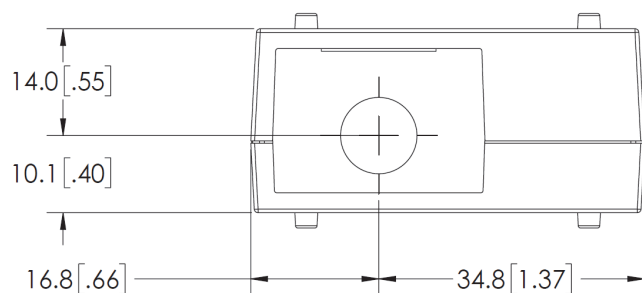

OPTICAL CENTER

A

### A-1-6 MicroHAWK V320-F Base

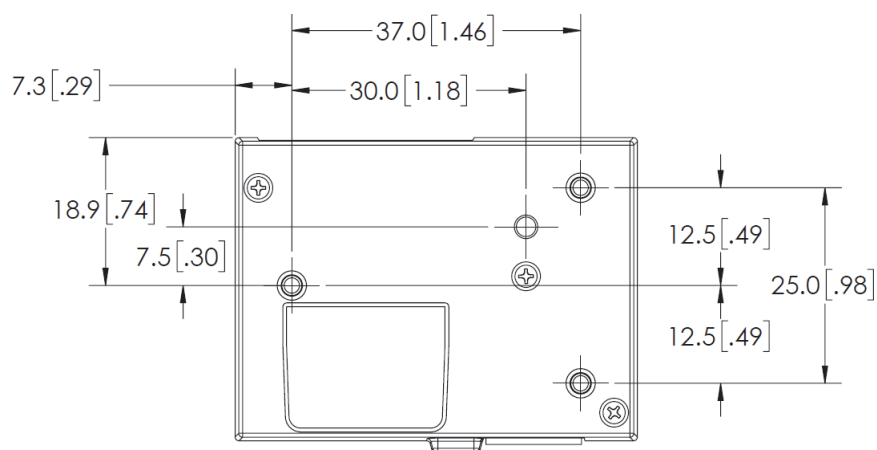

### A-1-7 MicroHAWK V320-F Top

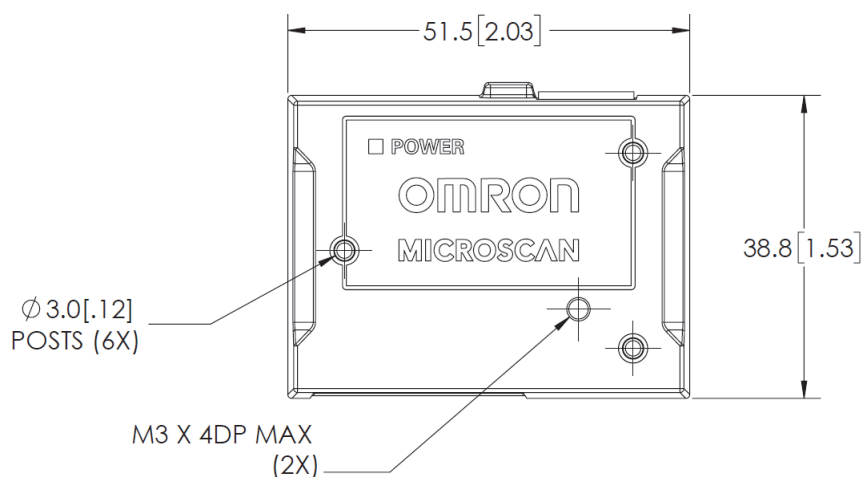

**A-1-8 MicroHAWK V330-F Front**

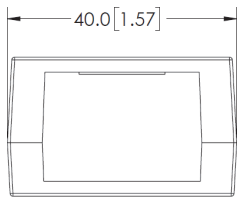

**A-1-9 MicroHAWK V330-F Base**

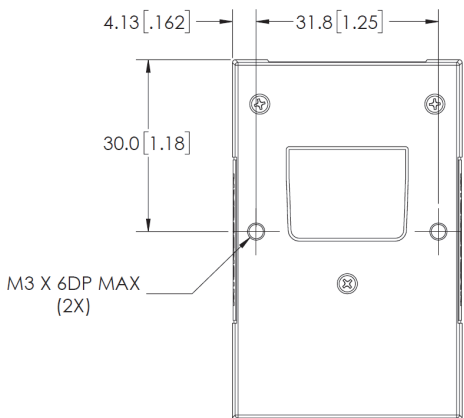

**A-1-10 MicroHAWK V330-F Top**

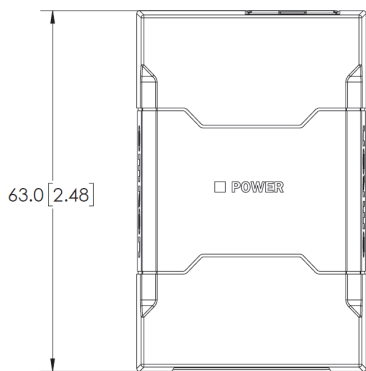

**A-1-11 MicroHAWK V330-F Side**

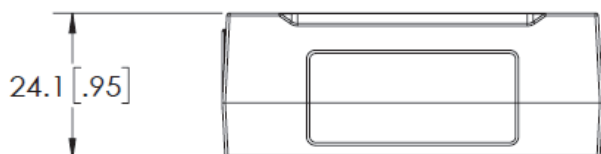

**A-1-12 MicroHAWK V420-F Front**

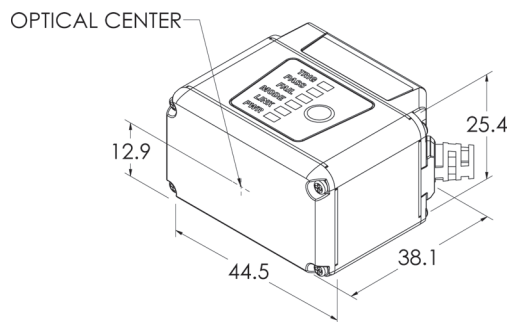

**A-1-13 MicroHAWK V420-F Base**

**A**

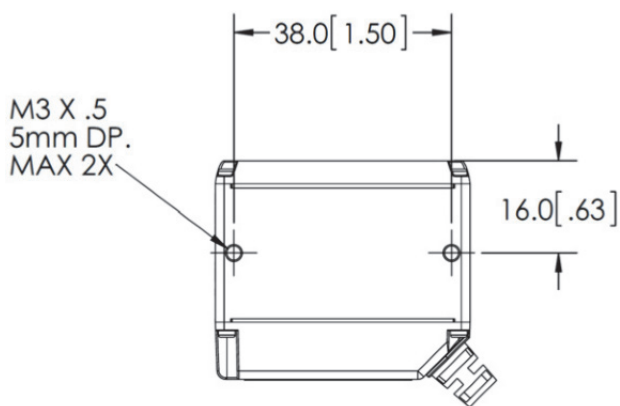

**A-1-14 MicroHAWK V420-F Top**

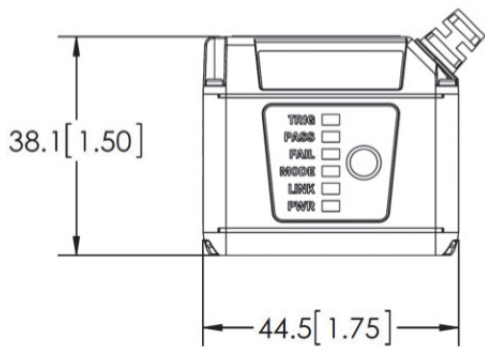

**A-1-15 MicroHAWK V420-F Side**

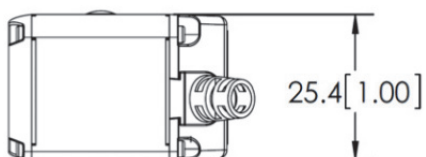

### A-1-16 MicroHAWK V430-F Front

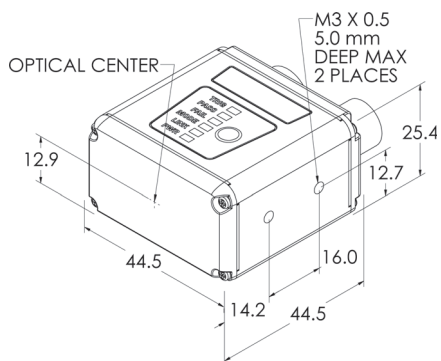

### A-1-17 MicroHAWK V430-F Base

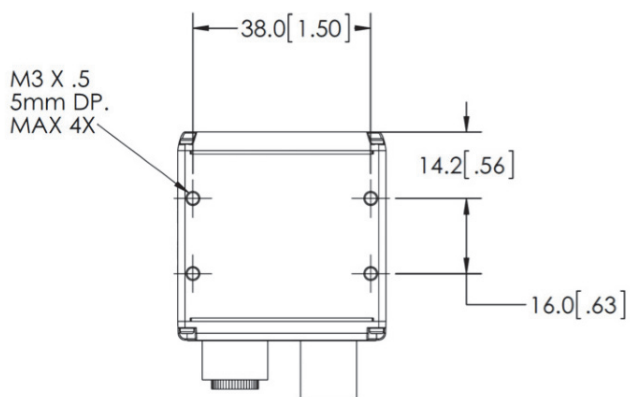

### A-1-18 MicroHAWK V430-F Top

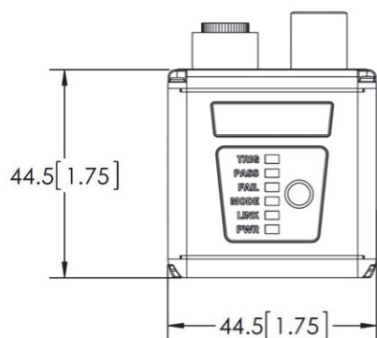

### A-1-19 MicroHAWK V430-F Side

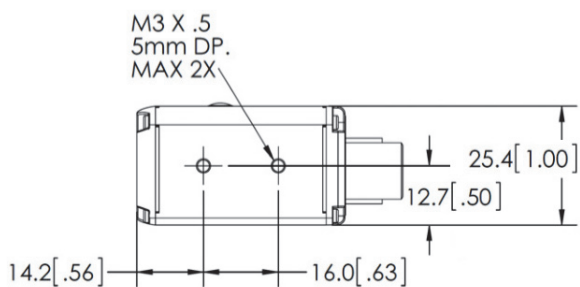

**A-1-20 MicroHAWK V430-F with Alternate Optics and Ring Light**

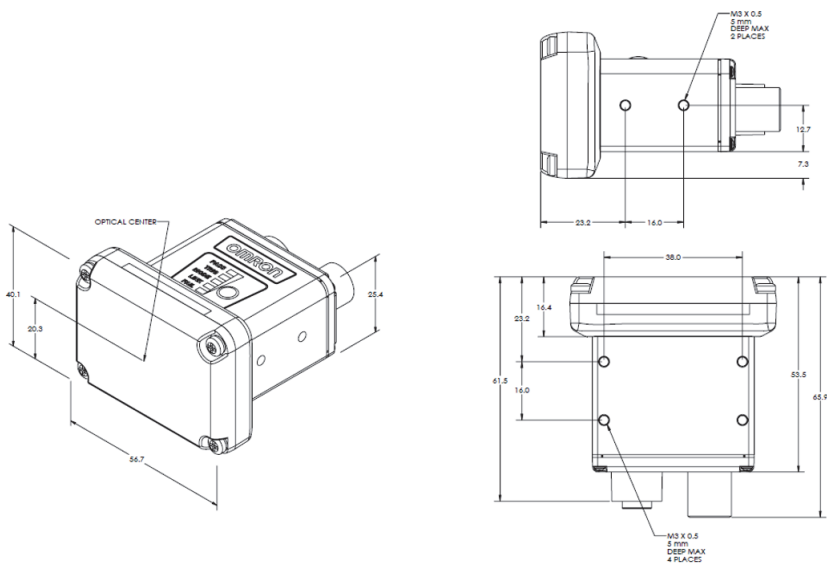

A

## A-2 Grounding and Power

### A-2-1 Ground and Shield Considerations

Proper grounding is necessary for operator safety, noise reduction, and the protection of equipment from voltage transients. Buildings, including any steelwork, all circuits, and all junction boxes must be grounded directly to an earth ground in compliance with local and national electrical codes.

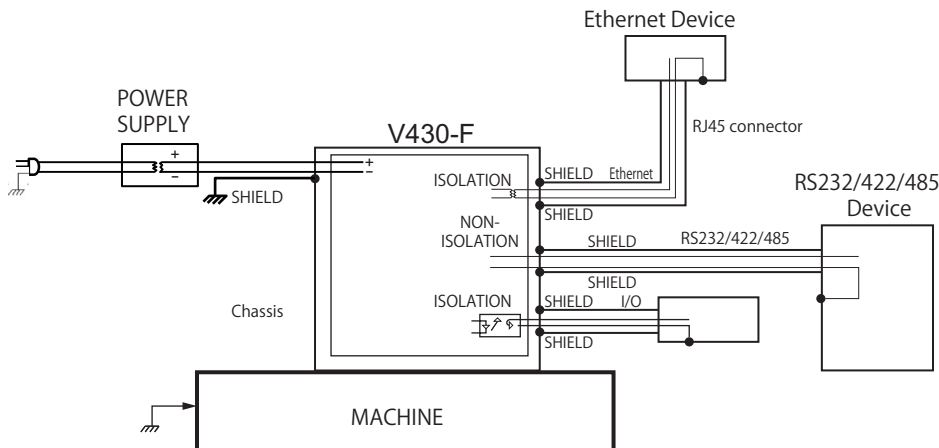

An earth ground is provided through the cable shields and chassis of the camera.

If the MicroHAWK malfunctions due to influence of the environment by shield cables grounded, try any of the ones below.

- Disconnect the chassis and the shield cable of the power supply from the earth.
- Ground the shield cable of the power supply to  $-(0V)$ .  
Ground any of one part of the shield cable, chassis, or RJ-45 connector of Ethernet cable to earth with D class grounding. Use a Class 2 power supply for the DC source.
- **Note:** In the case of this connection, must not ground the  $+(24V)$  of the power supply. If connected, the device will break down due to a short circuit.

### A-2-2 Ground Loops

Ground loops (signal degradation due to different ground potentials in communicating devices) can be eliminated or minimized by ensuring that both the host, imager, and their power supplies are connected to a common earth ground.

- **Note:** If a malfunction occurred to your reader by noise, mount a noise filter (RSAL2001W manufactured by TDK-Lambda Corp.) close to the reader's power-supply terminals and ground the chassis of the filter.



### A-2-3 Expected Power and Ground Connections for Proper Operation

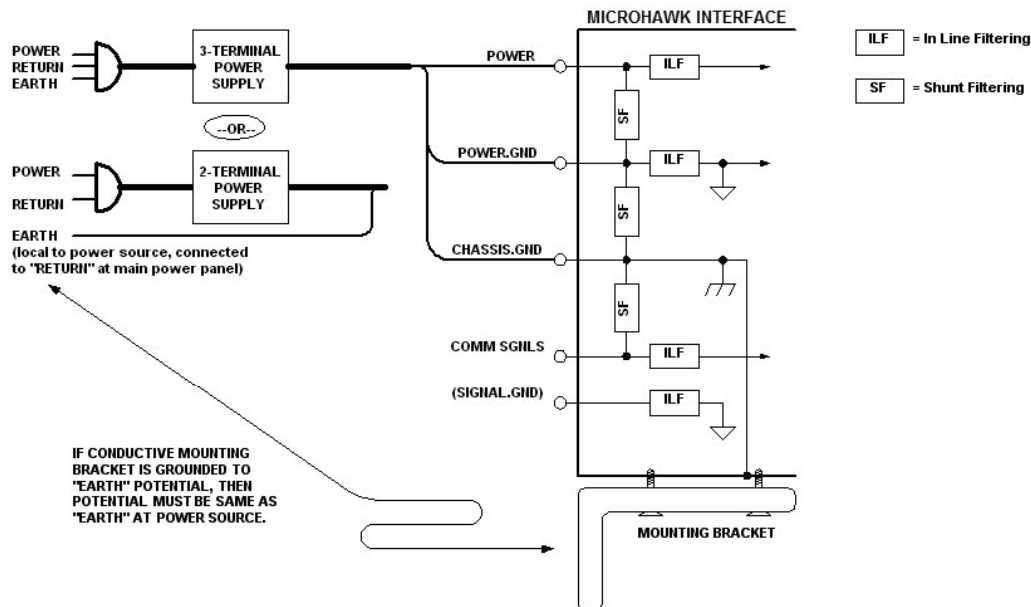

A

### A-2-4 Grounding Notes

- Ensure that mounting bracket "Earth" is at the same potential as power source "Earth".
- Supply "Return" and "Earth" ground must be stable, low-impedance reference points.
- "2-Terminal Power Supply" must still provide an "Earth" connection to the imager.
- "Signal Ground" can be used for communications and/or discrete signal ground reference. It must **not** be used as Power Ground or Earth Ground.

# A-3 Accessories and Cables

## A-3-1 MicroHAWK Accessories

✓ = Supported

x = Not Supported

Category	Part Number	Description	Camera				
			V420-F	V430-F	V430-F with Ring Light	V320-F	V330-F
Standard Optical Accessories and Lighting	V430-AF10	Front Window Installation Kit	✓	✓	x	x	x
	V430-AF11	Diffuser Installation Kit	✓	✓	x	x	x
	V430-AF12	Polarizer Installation Kit	✓	✓	x	x	x
	V430-AF3	Right-Angle Mirror Installation Kit	✓	✓	x	x	x
	V430-AF4	YAG Filter Installation Kit	✓	✓	x	x	x
	V430-AF5	ESD-Safe Window Installation Kit	✓	✓	x	x	x
	V430-AF6	Red Filter Installation Kit	✓	✓	x	x	x
	V430-AF7	Blue Filter Installation Kit	✓	✓	x	x	x
	V430-ALR	Red Light Installation Kit	✓	✓	x	x	x
	V430-ALW	White Light Installation Kit	✓	✓	x	x	x
	V430-ALB	Blue Light Installation Kit	✓	✓	x	x	x
	V430-ALI	IR Light Installation Kit	✓	✓	x	x	x
Ring V4X0-F Optical Accessories and Lighting	V430-AF0R	Front Window Installation Kit	x	x	✓	x	x
	V430-AF1R	Diffuser Installation Kit	x	x	✓	x	x
	V430-AF2R	Polarizer Installation Kit	x	x	✓	x	x
	V430-ALRR	Red Ring Light Installation Kit	x	x	✓	x	x
	V430-ALWR	White Ring Light Installation Kit	x	x	✓	x	x
	V430-ALBR	Blue Ring Light Installation Kit	x	x	✓	x	x
	V430-ALIR	IR Ring Light Installation Kit	x	x	✓	x	x
Mounting Accessories	V430-AM0	L-Bracket Adjustable-Angle Mounting Kit	✓	✓	✓	x	x
	V430-AM1	¼-20 Camera Mounting Block Kit	✓	✓	✓	x	x
	V430-AM2	4" (102 mm) Ram Mount Stand	✓	✓	✓	x	x
	V430-AM3	APG Pan and Tilt Camera Mount	✓	✓	✓	x	x
	V430-AM4	Nylon Screw and Washer Electrical Isolation Kit	✓	✓	✓	x	x
	V430-AM6	Smart Ring Light-to-V4X0-F Mounting Bracket	✓	✓	x	x	x
V3X0-F Optics Accessories	V330-AF1	Diffuser Kit – Peel and Stick Accessory	x	x	x	✓	✓
	V330-AF2	Polarizer Kit – Peel and Stick Accessory	x	x	x	✓	✓

## A-3-2 Diffuser

### V430-AF11

Spreads out light.

Reduces direct reflection of LEDs.

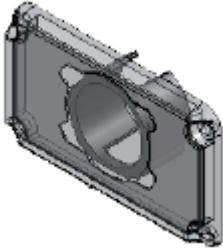

**Accessories:**  
Gasket (1)  
Phillips-Head Screws (4)

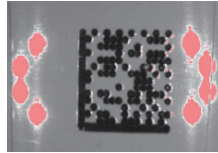

Without Diffuser



With Diffuser

## A-3-3 Polarizer

### V430-AF12

Reduces glare from specular objects.

Passes light from diffuse objects.

Filters out specular (vertical) reflection.

Only the horizontal component of diffuse reflection is "seen" by the reader.

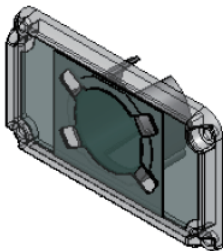

**Accessories:**  
Gasket (1)  
Phillips-Head Screws (4)

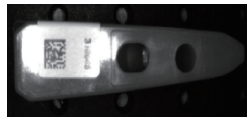

Without Polarizer

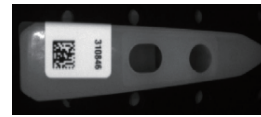

With Polarizer

### How to Install V430-AF11/AF12

- Disconnect power from the reader.
- Remove the four screws from the front window of the reader.
- Remove the front window and gasket.
- Install the gasket onto the reader. Ensure that the gasket is properly seated in place and is covering all sealing surfaces.
- Install the window: V430-AF10 (or window accessory: V430-AF11/AF12) onto the reader.
- Secure the window in place using the screws provided. Do not over-tighten the screws. (1.0 in./lbs. (0.11 nm max.).



### A-3-4 Right Angle Mirror

#### V430-AF3 (Unit: [mm])

Allows the reader to fit into compact spaces.

Reverses the image.

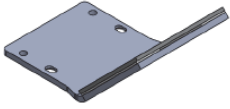

**Bracket(1) (Material: Aluminum)**  
**Mirror(1) (Material: Glass)**

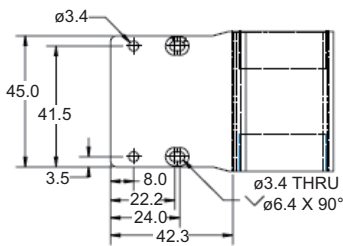
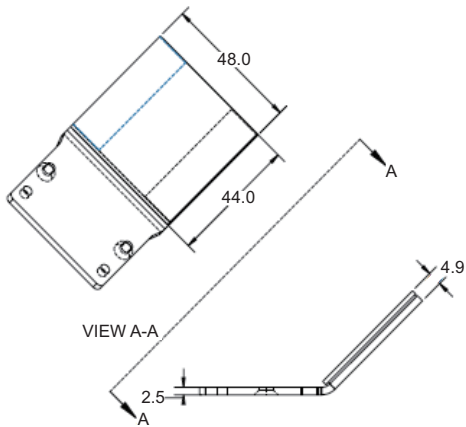
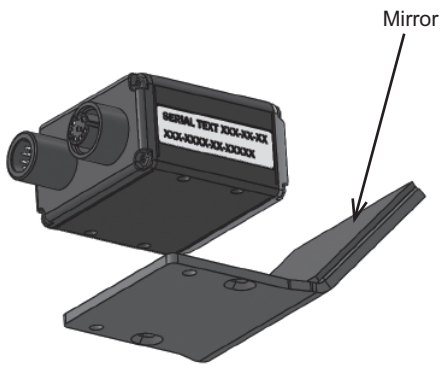

## A-3-5 Mounting Bracket (Sold Separately)

### Angle-Adjustable L Bracket

V430-AM0 (Unit: [mm])

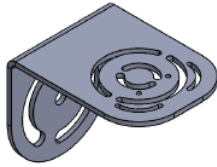

Material: SUS304  
 Thickness: 2.5 mm  
 Accessories: Phillips-HeadScrews (M3×6) (2)  
 Washer (M3) (2)

The following accessories are not used with the MicroHAWK V430-F-Series:

- Phillips-Head Screws (M2×6) (2)
- Washers for M2 Screws (2)

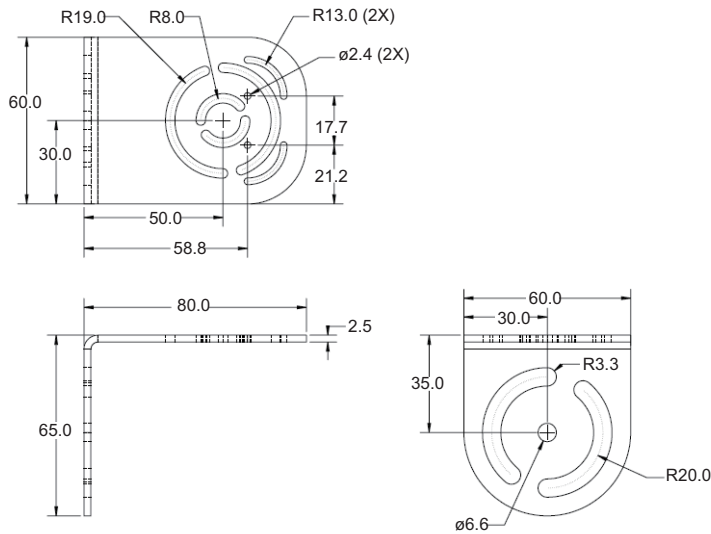

A

### Installation Method

In case of side installation:

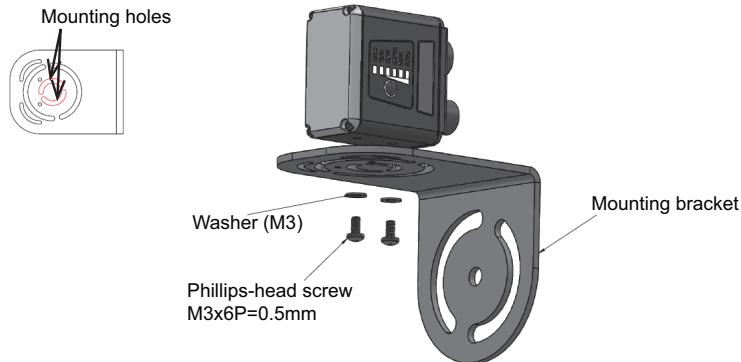

In case of base installation:

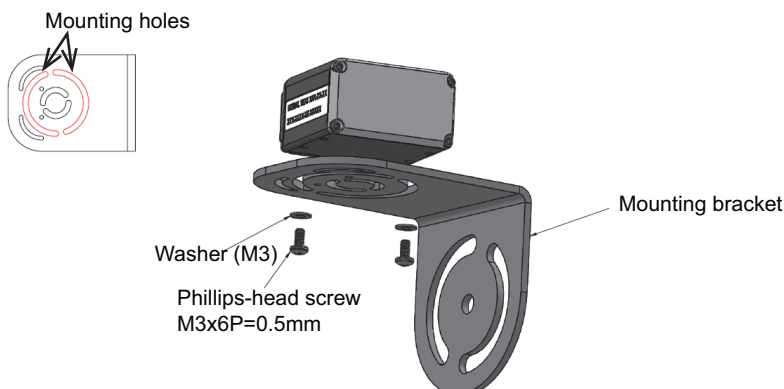

## Mounting Block

### V430-AM1 (Unit: [mm])



Material: Aluminum alloy  
 Thickness: 6.4mm  
 Accessories: Cap Screws (M3×6)(2)  
 The following accessories are not used with the MicroHAWK V430-F-series:  
 Cap Screws (M2×8)(2)

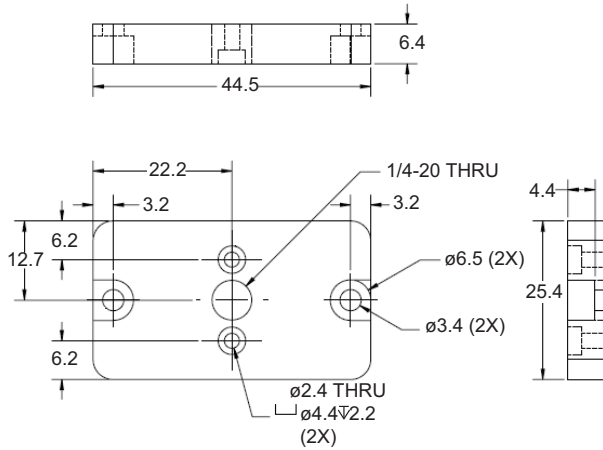

Mounting holes

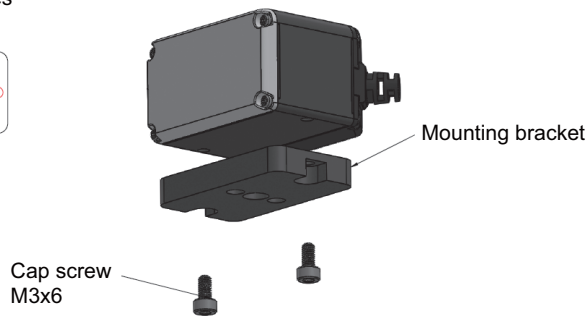
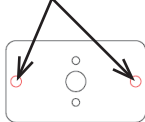

**Note:**

- Mounting the MicroHAWK V430-F requires the use of the front set of mounting holes, closest to the window.
- As the material is aluminum alloy, there is no isolation effect. Although the body case of V430 is connected to FG (Frame ground), the FG is isolated from the internal electric circuit GND (0 VDC). If noise affects it, take measures by referencing Grounding and Power section.

## A-3-6 MicroHAWK V320-F and V330-F Accessories

**Diffuser Kit – Peel and Stick Accessory. Exterior to unit.**  
**V330-AF1**

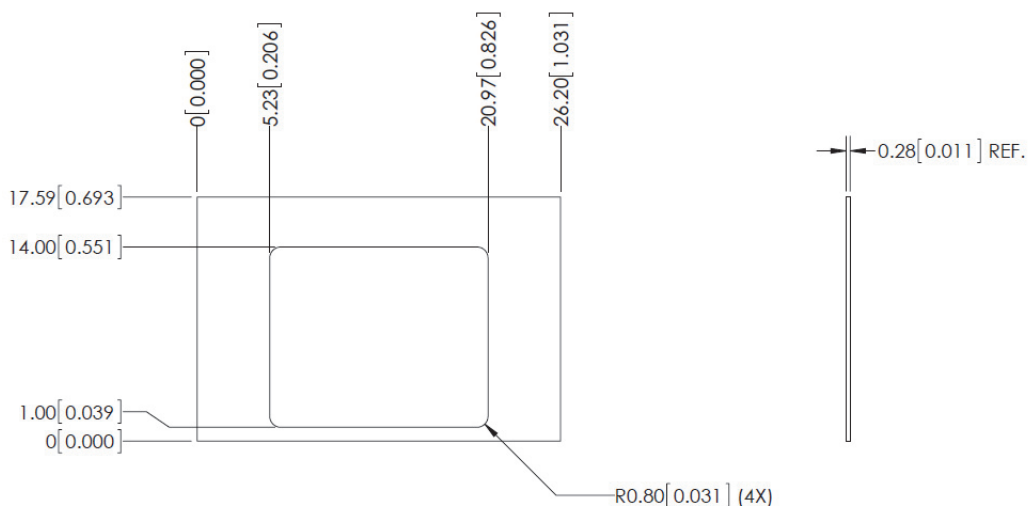

**A**

**Polarizer Kit – Peel and Stick Accessory. Exterior to unit.**  
**V330-AF2**

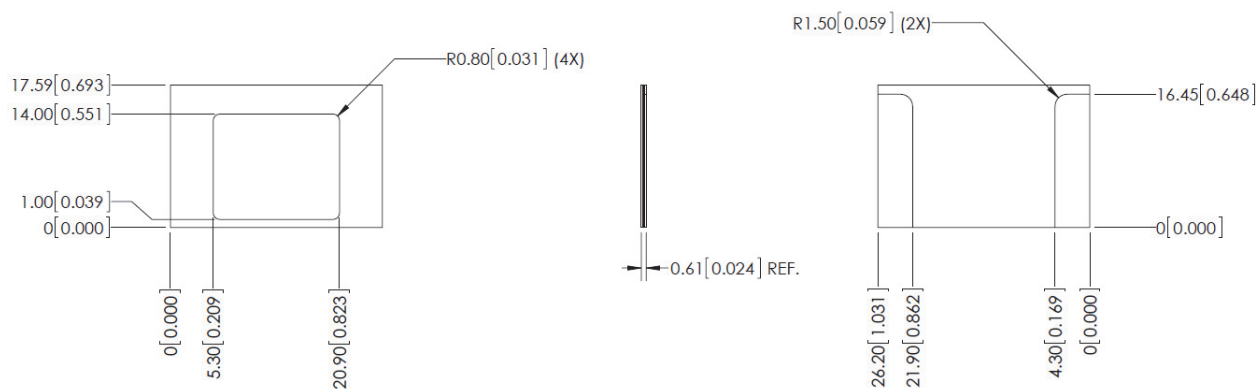
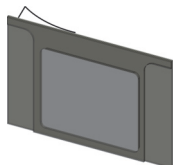

### A-3-7 MicroHAWK V420-F and V430-F Accessories

#### L Bracket Adjustable Angle Mounting Kit V430-AM0

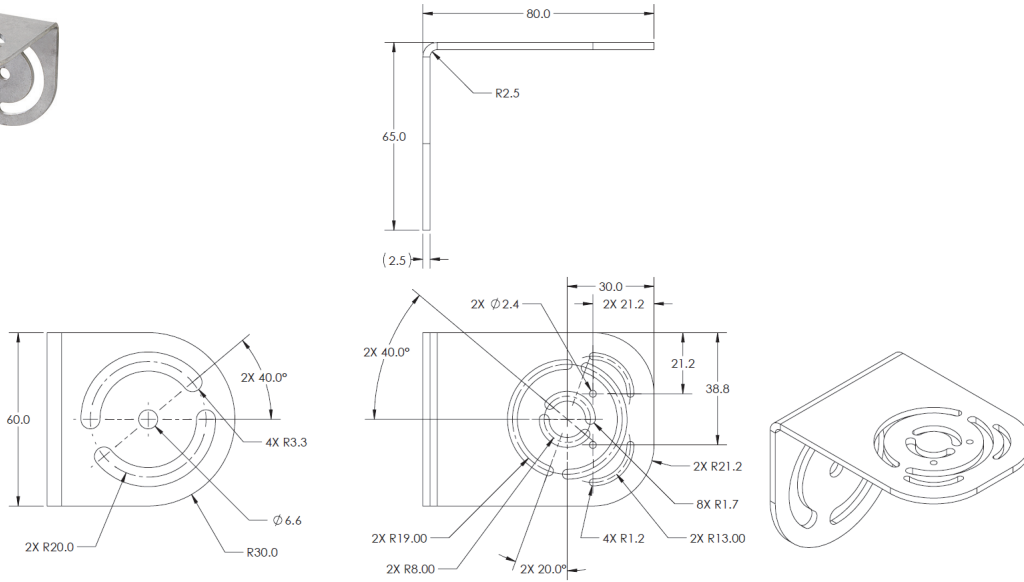

#### 1/4-20 Camera Mounting Block Kit V430-AM1

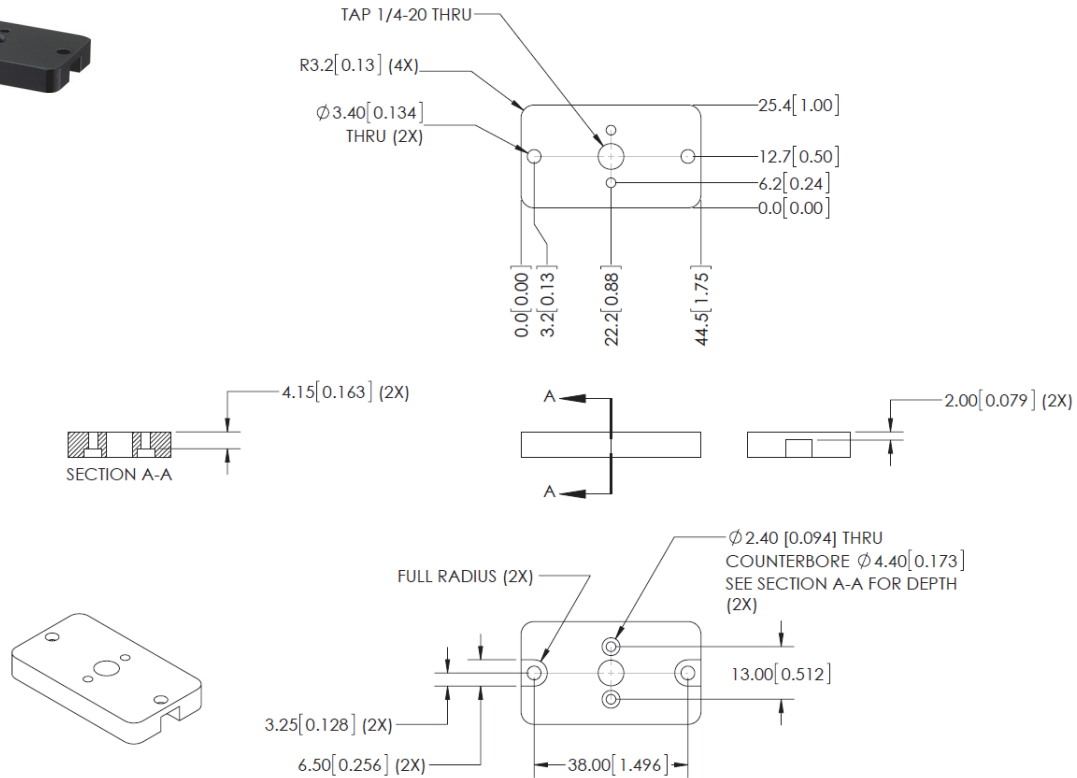



**4" (102 mm) Ram Mount Stand  
V430-AM2**

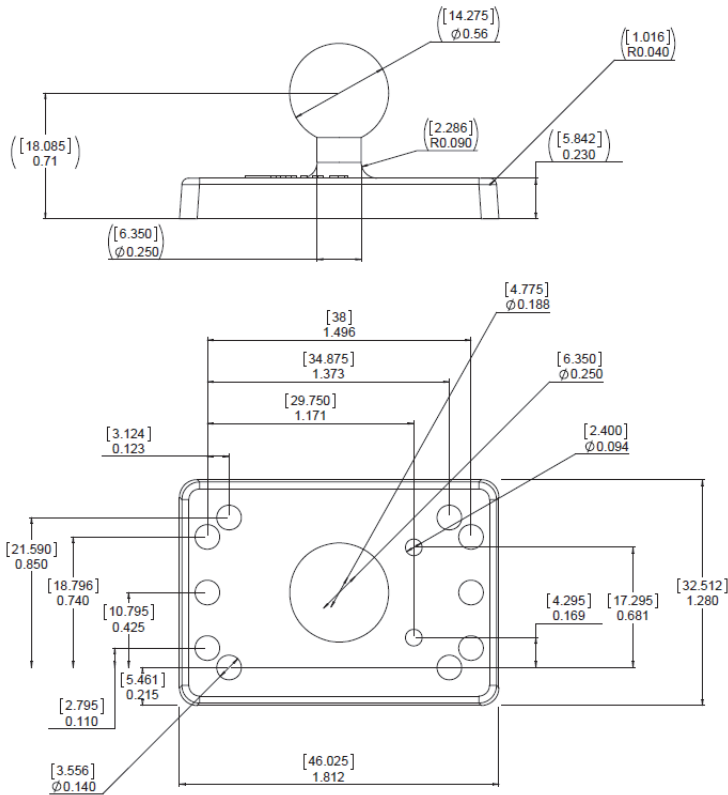

**MS-4 / MINI to V/F4XX-F Adapter Plate  
V430-AM5**

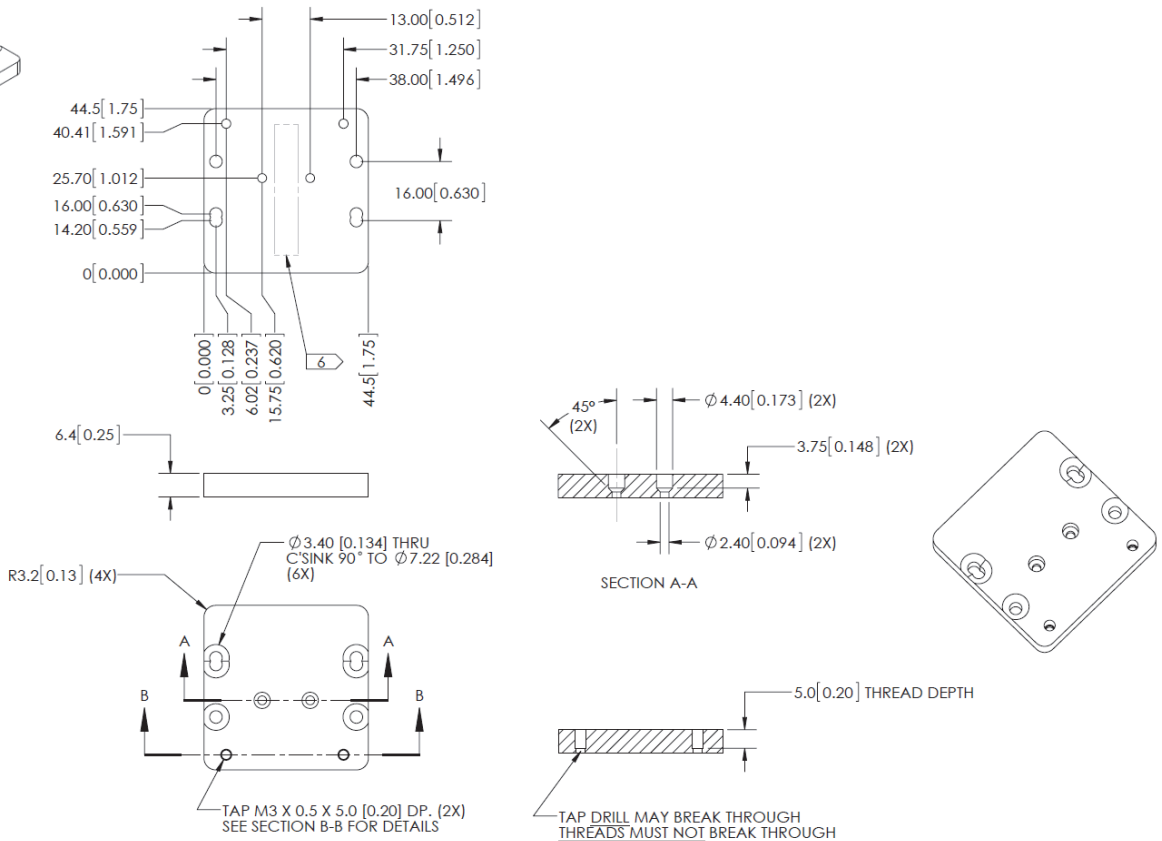
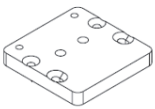

**Smart Ring Light to V/F4XX-F Mounting Bracket  
V430-AM6**

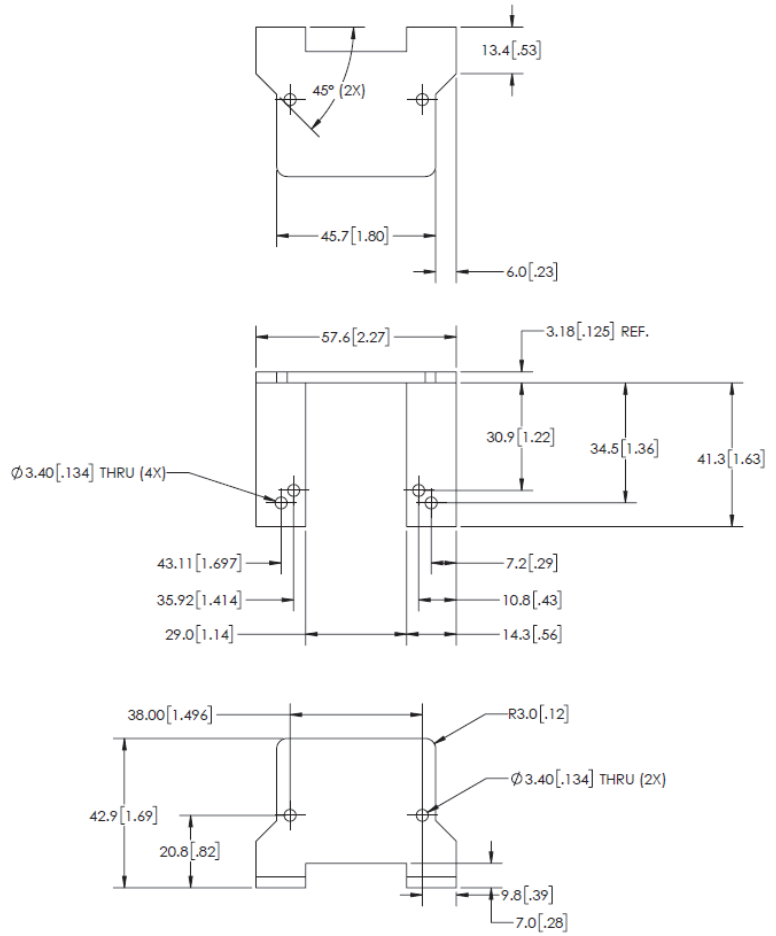
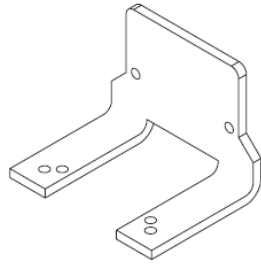
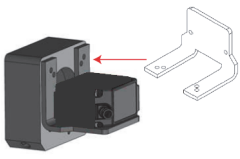

**QX / Vision HAWK to V/F4XX-F Adapter Plate  
V430-AM7**

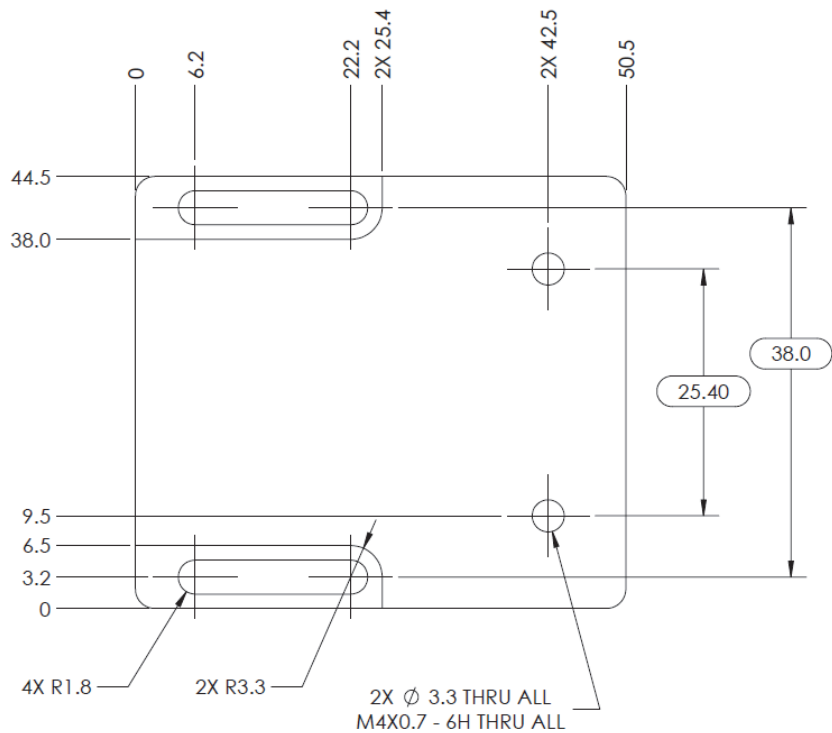
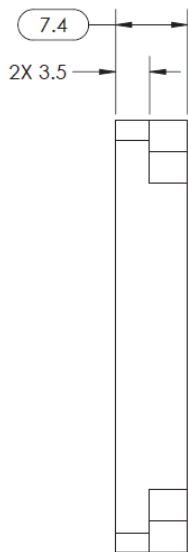
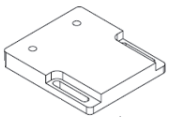

**Front Window Installation Kit  
V430-AF10 \***

**Diffuser Installation Kit  
V430-AF11 \***

**Polarizer Installation Kit  
V430-AF12 \***

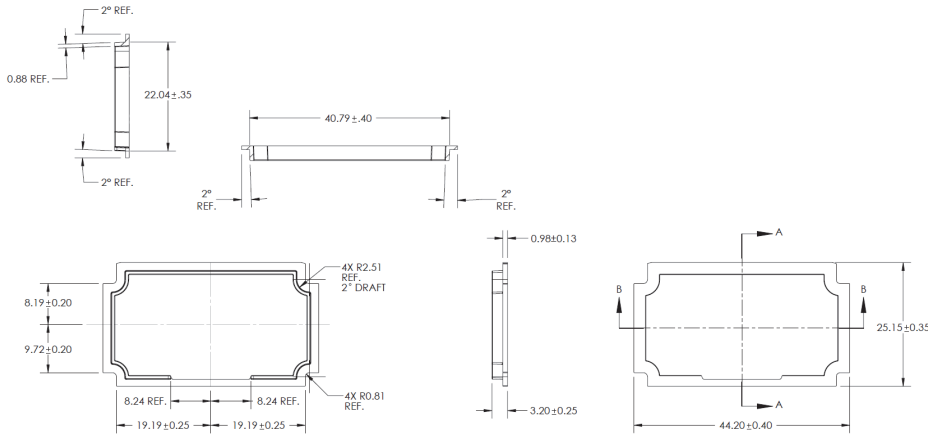
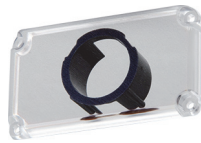

**\* Note:** V430-AF10, AF11, and AF12 are used for **MicroHAWK V/F4X0-FXXXXXXX-XXX** readers in this manual. The prior generation **MicroHAWK V430-FXXXXXXX** code reader uses part numbers V430-AF0, AF1, and AF2. Please select the correct accessory from the table based on your reader part number format.

Accessory	Prior V430-FXXXXXXX Code Reader	New V/F4X0-FXXXXXXX-XXX Code Reader and Smart Camera
Front Window Installation Kit	V430-AF0	V430-AF10
Diffuser Installation Kit	V430-AF1	V430-AF11
Polarizer Installation Kit	V430-AF2	V430-AF12

**Right Angle Mirror Installation Kit  
V430-AF3**

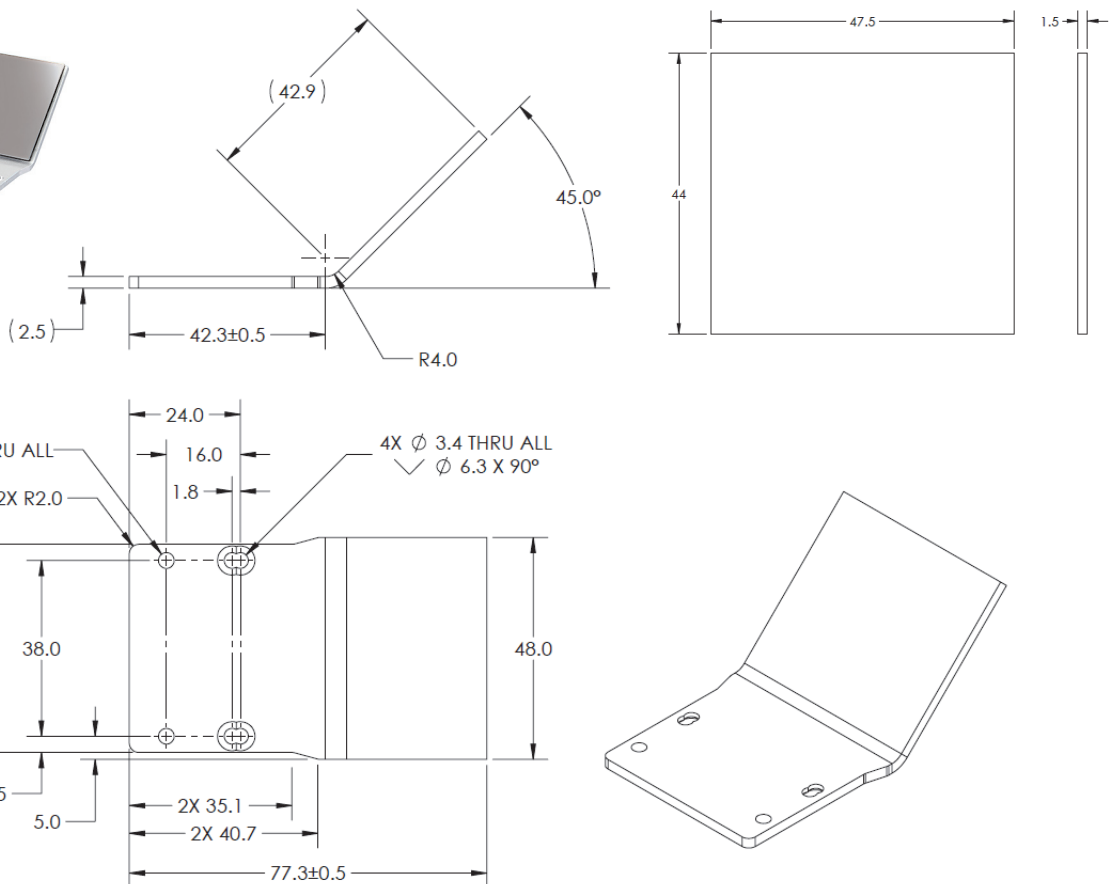

**YAG Laser Filter Window  
V430-AF4**

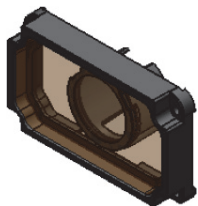

**Window Material**

Polymer

**Laser Type**

Argon  
Broadband  
KTP  
Nd:YAG

**Protection**

OD 6+ @ 200-532 nm  
OD 4+ @ 850-879 nm  
OD 5+ @ 900-1070 nm

The V430-AF4 YAG Laser Filter is used to block a range of wavelengths from a variety of laser types from being seen by the MicroHAWK camera that will either disrupt the cameras view of the object, or damage the MicroHAWK sensor.

The table shows the laser types that are handled by the V430-AF4 Filter window, as well as the level of protection they provide at the various wavelengths.

**Note:** Optical Density (OD) is a measure of the attenuation of energy passing through a filter. The higher the OD value, the higher the attenuation and the greater the protection level.

OD 4 blocks 99.99% of the laser energy.

OD 5 blocks 99.999% of the laser energy (YAG).

OD 6 blocks 99.9999% of the laser energy (Argon, KTP)

**ESD-Safe Window  
V430-AF5**



An ESD event occurs when an electrostatic charge rapidly transfers between two objects. This transfer is usually caused when two objects with a notable potential difference in electrical charge contact each other. However, ESD events can also happen when two objects close to one another create a highly charged electrostatic field.

ESD safety precautions are extremely important in the electronics and semiconductor industries where sensitive components can be damaged even by a discharge of a mere 20 volts. Less sensitive components may still be susceptible, and cumulative discharges can create long-term problems affecting the functionality and performance of electronic components.

The MicroHAWK V430-AF5 ESD-Safe window is designed with an ESD coating on the exterior surface to prevent static discharge between the reader or smart camera when the camera is deployed close to the component surface. The antistatic coating offers a resistivity of  $\leq 1.0 \times 10^9 \Omega/\text{sq}$  to prevent these electrostatic discharges.

**Red Filter Installation Kit  
V430-AF6**

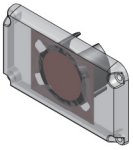

**Blue Filter Installation Kit  
V430-AF7**

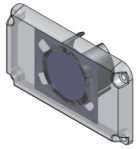

**Red Light Installation Kit  
V430-ALR**

**White Light Installation Kit  
V430-ALW**

**Blue Light Installation Kit  
V430-ALB**

**IR Light Installation Kit  
V430-ALI**

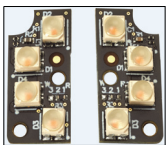

**Red Filter (V430-AF6) and Blue Filter (V430-AF7)**

The Red Filter (V430-AF6), and Blue Filter (V430-AF7) are used to turn MicroHAWKs equipped with white lights into units that emit red or blue light. MicroHAWK light color changes can be also be accomplished using the V430-F Red, Blue, White, or IR LED kits.

A typical example of how to use different color filters or LEDs with monochrome readers is shown below. The emitted color is matched with the color of the part that needs to be emphasized or de-emphasized, which creates sufficient contrast for the part to be inspected or for the symbol to be decoded. In the example below, the red filter makes the reddish copper look bright, while the green circuit board looks dark. The blue filter produces the opposite effect.

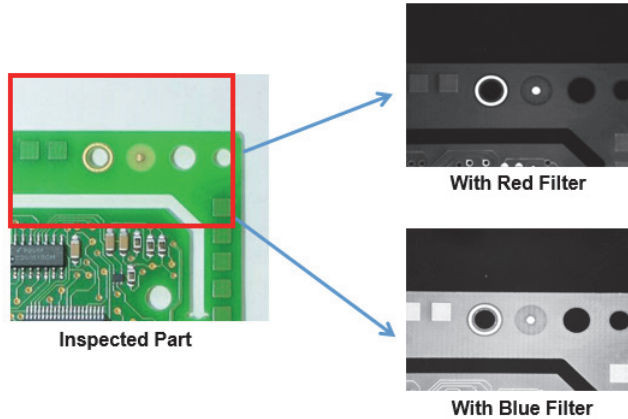

A

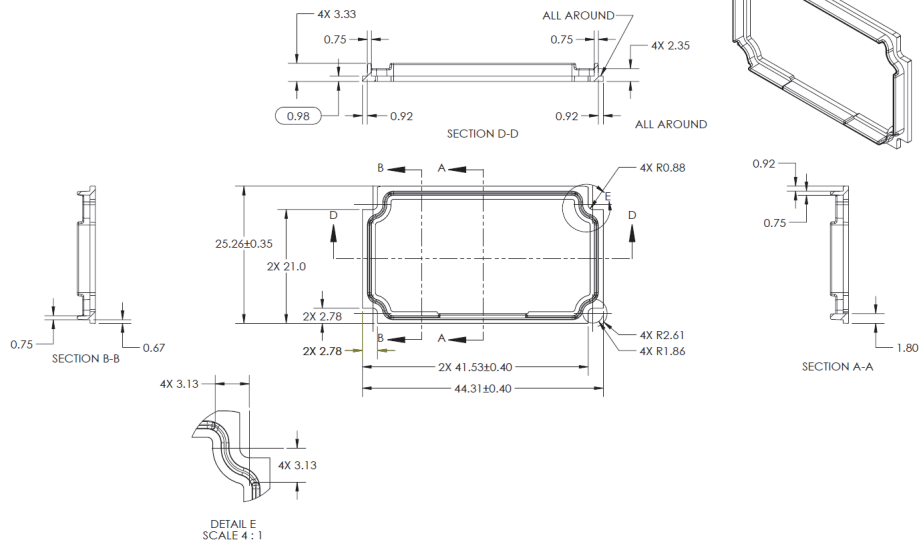

**QX-1 Interconnect Module – Power, Trigger, Smart Light Control Breakout  
98-000103-02**

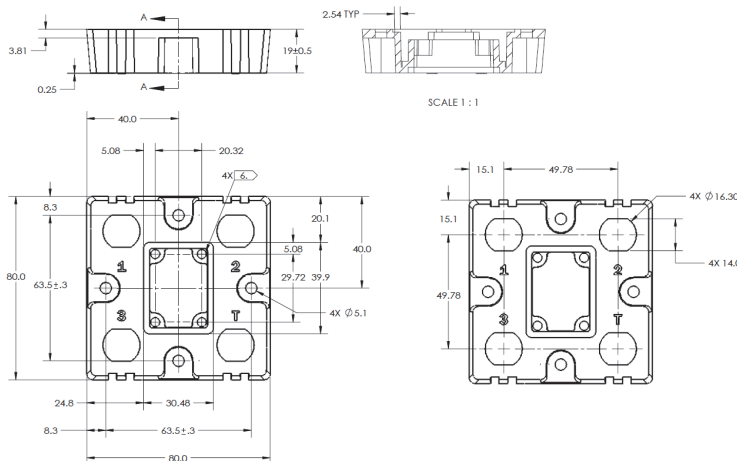

**QX-1 Photo Sensor, M12 4-Pin Plug, NPN – 2 Meters – Light ON / Dark ON**  
**99-900016-01**

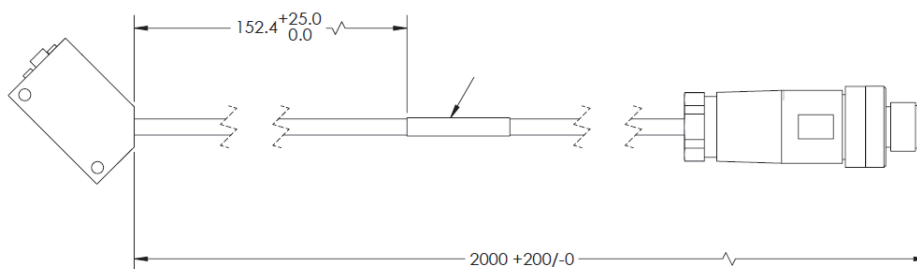

**QX-1 Field-Wireable M12 4-Pin Plug for Any Trigger Source or Photo Sensor – Screw Terminals**  
**98-9000239-01**

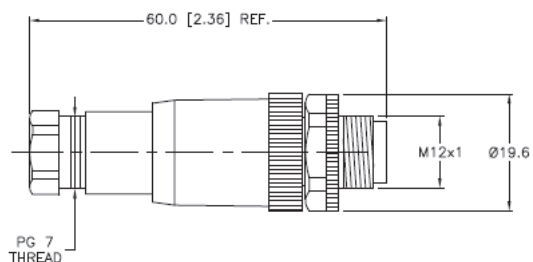

**Power Supply, 100-240VAC, +24VDC, M12 12-Pin Socket – 1 Meter – U.S. / Euro Plug**  
**97-000012-01**

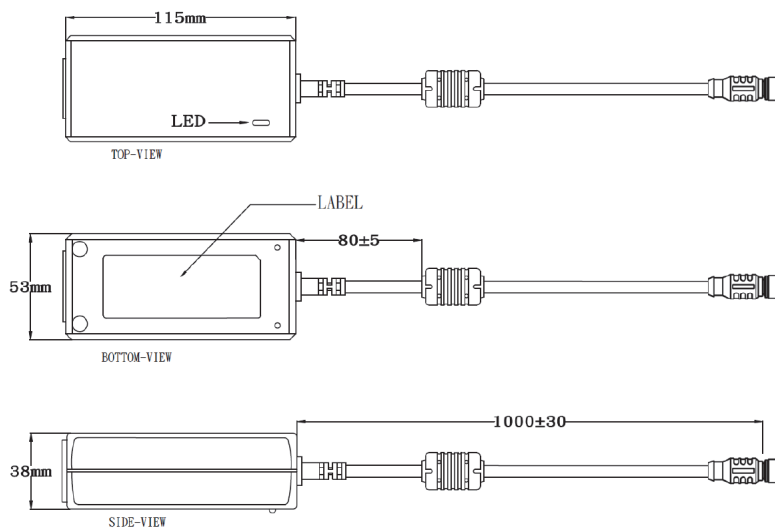



### A-3-8 MicroHAWK V320-F Cables with Pinouts and Wire Colors

#### V320-WRX-2M – RJ50 to RS-232 and External Power Straight – 2 M

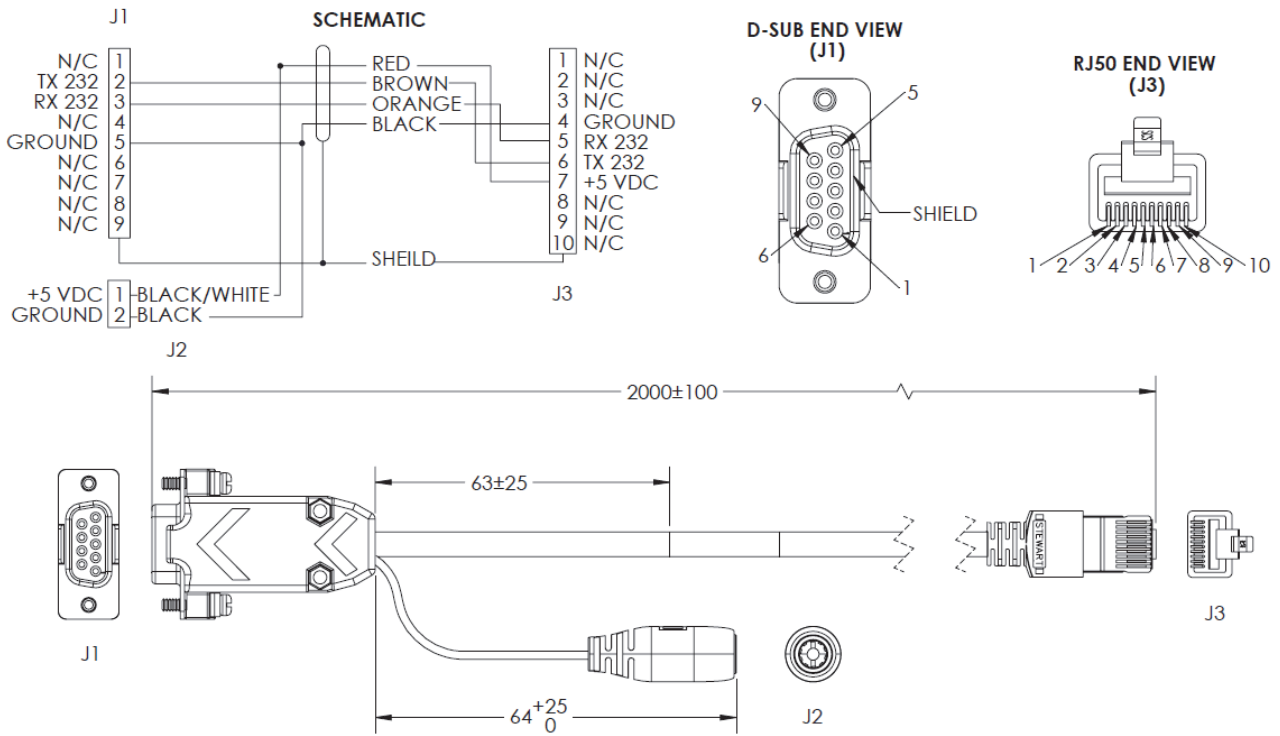

#### V320-WRXLR-2M – RJ50 to RS-232 and External Power Right Angle – 2 M

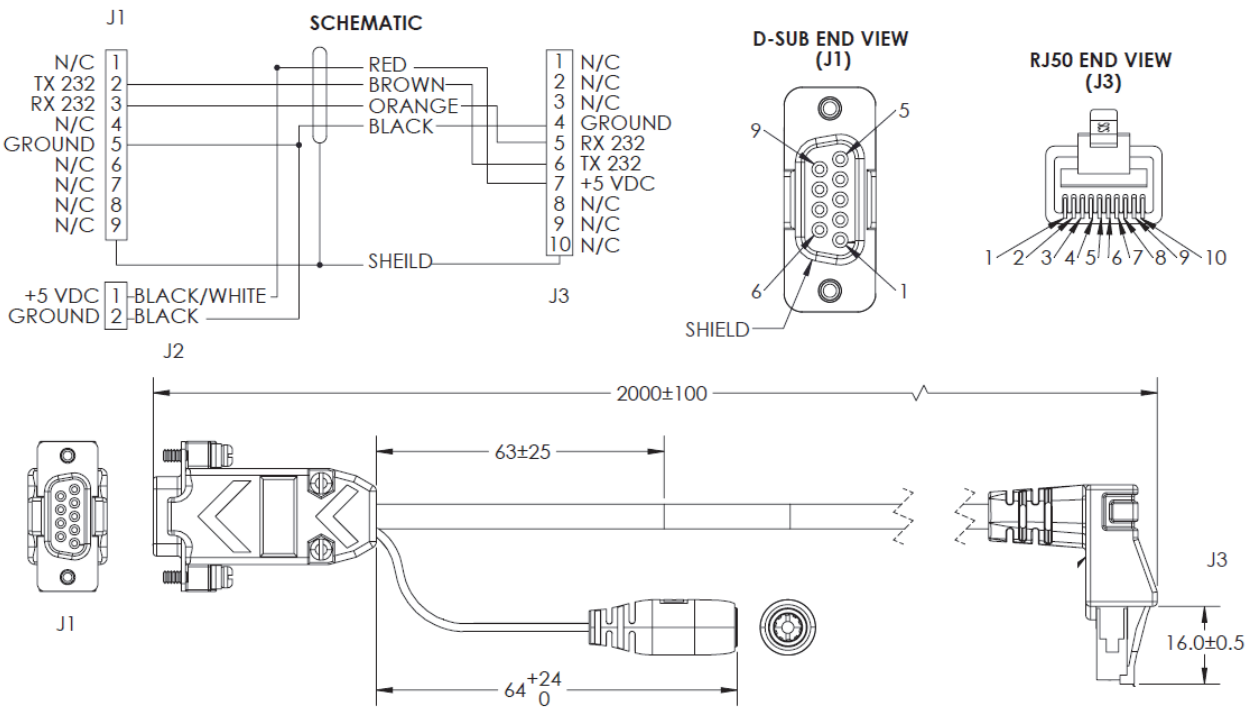



### V320-W8-3M – RJ50 to Flying Leads, Straight – 3 M

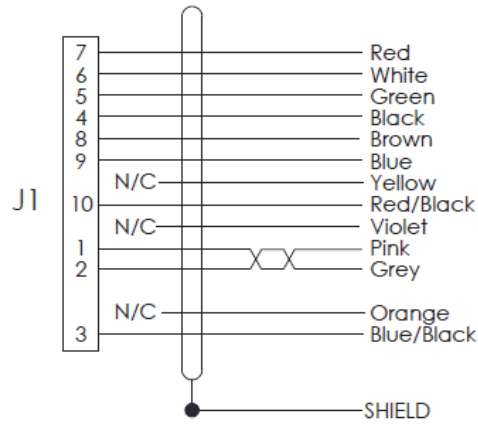

RJ50 END VIEW (J1)

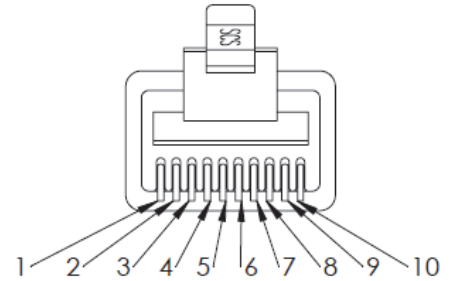

SCHEMATIC

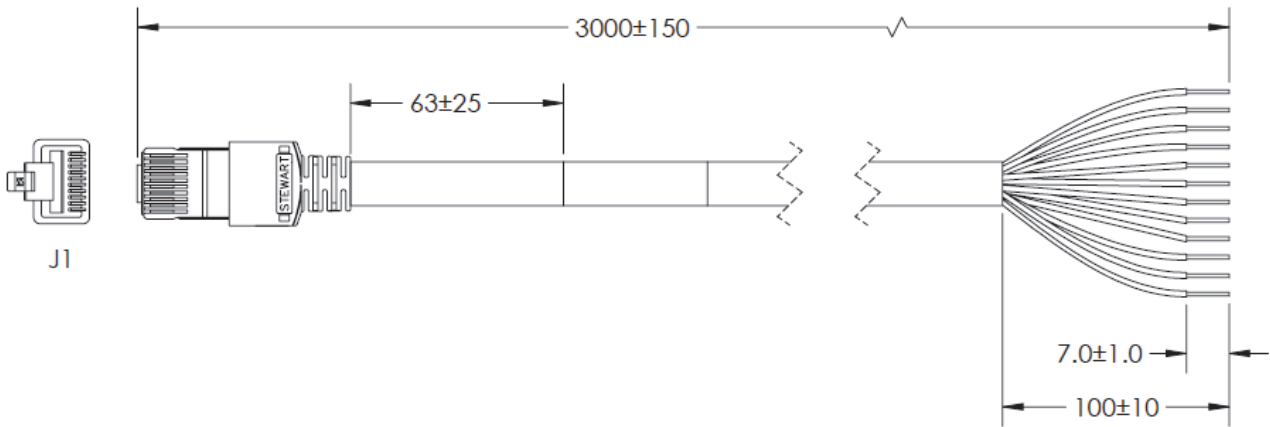

A

### V320-W8LR-3M – RJ50 to Flying Leads, Right Angle to the Right – 3 M

#### SCHEMATIC

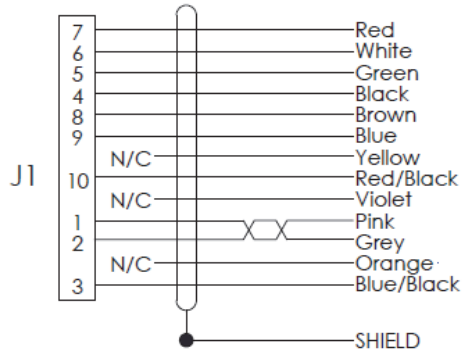

#### RJ50 END VIEW (J1)

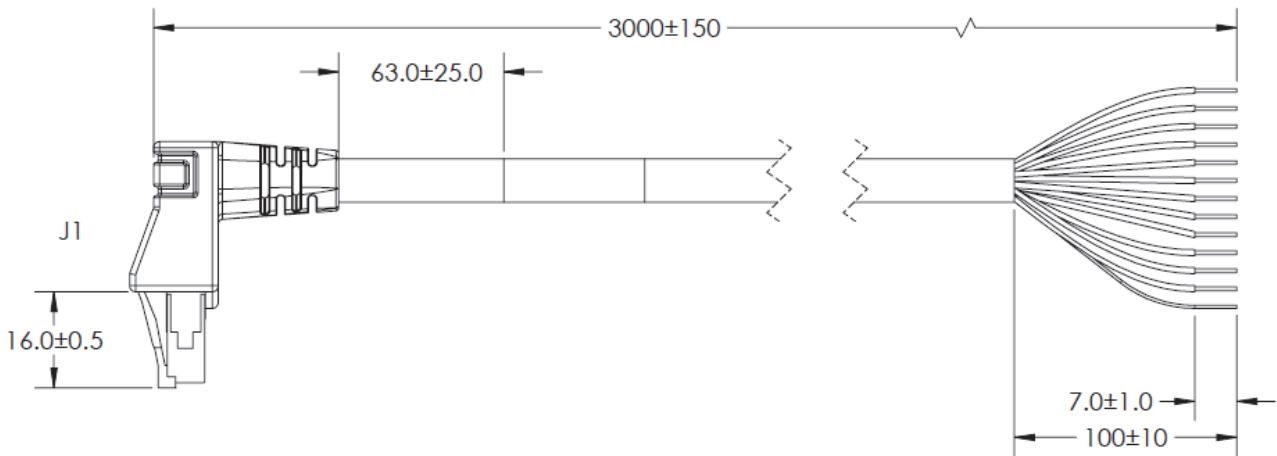
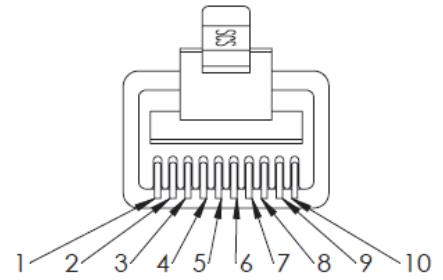

### V320-WR-1M – Adapter V320-F to all V420-F Cable Accessories, RJ50 to DB-15 – 1 M

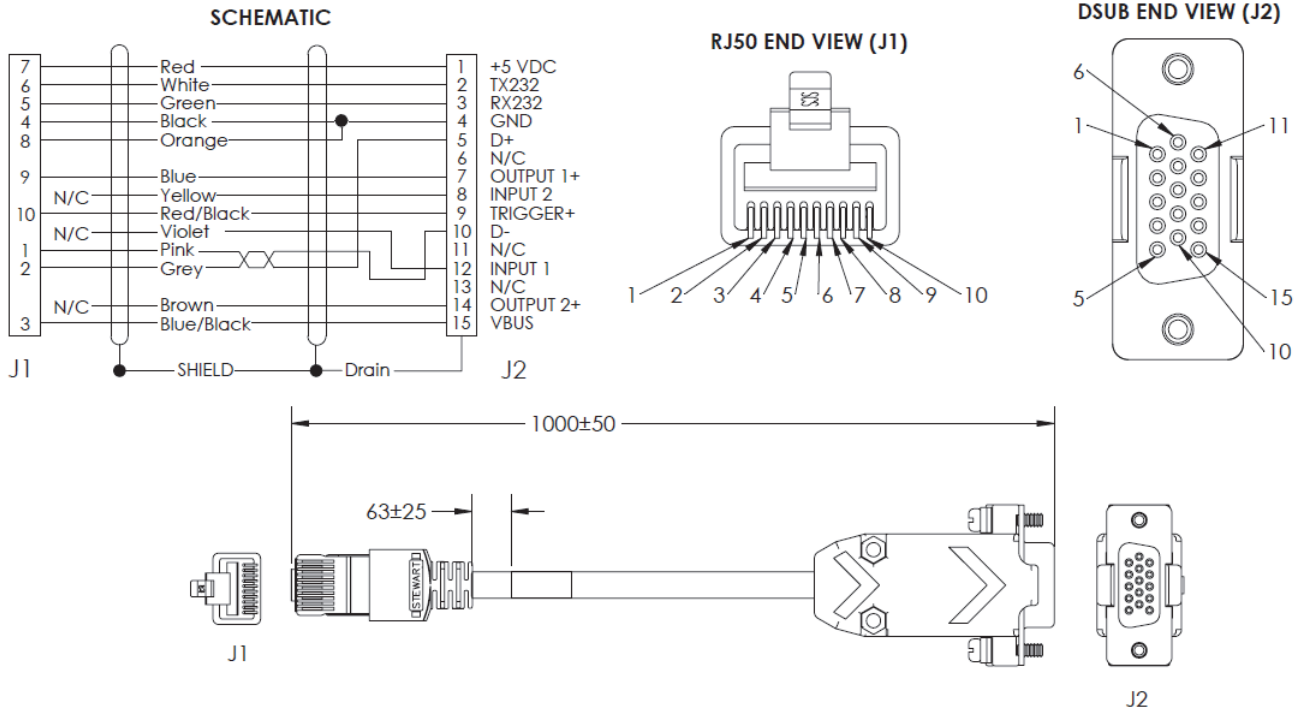

**A**

## V320-WRLR-1M – Adapter V320-F to all V420-F Cable Accessories, Right Angle to the Right, RJ50 to DB-15 – 1 M

**D-SUB END VIEW (J2)**

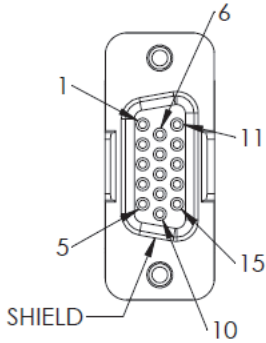

**RJ50 END VIEW (J1)**

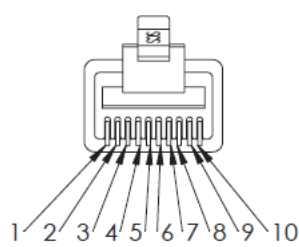

**SCHEMATIC**

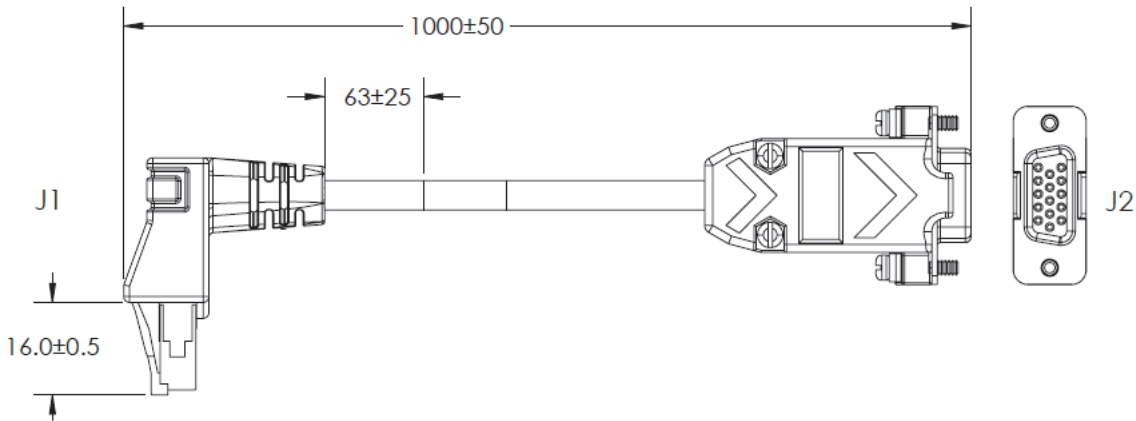
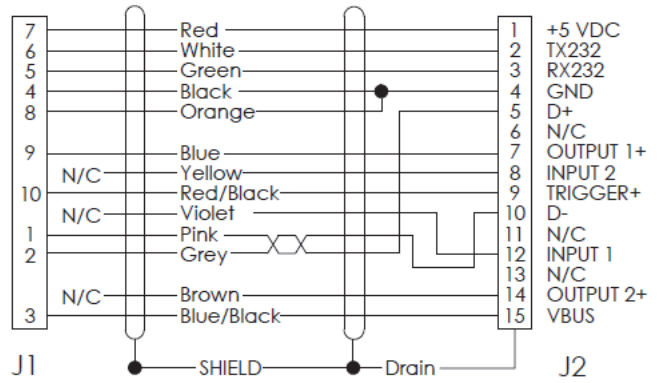

**A-3-9 MicroHAWK V330-F Cables**

**Standard Ethernet Cables, In-Cabinet Use; Standard RJ45 Connectors on Both Ends; Green**

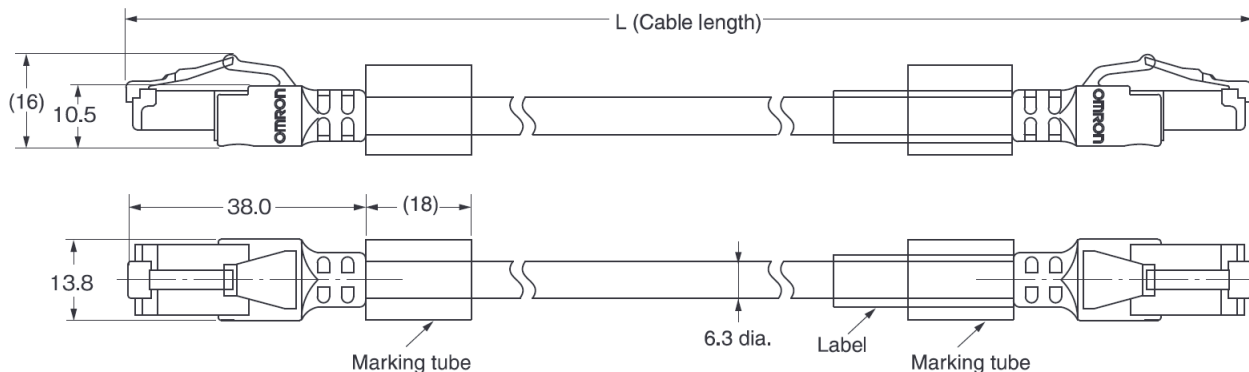

**A**

**Standard Ethernet Cables, Out-of-Cabinet Use; Rugged RJ45 Connectors on Both Ends; Light Blue**

*or*

**High Flex Ethernet Cables for Robot and Cable Tray Use; Rugged RJ45 Connectors on Both Ends; Light Blue**

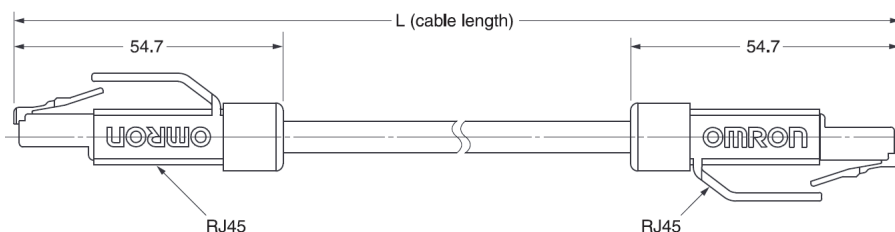

### A-3-10 MicroHAWK V420-F Cables with Pinouts and Wire Colors

#### V420-WUB-1M – USB Breakout Cable – 1 M

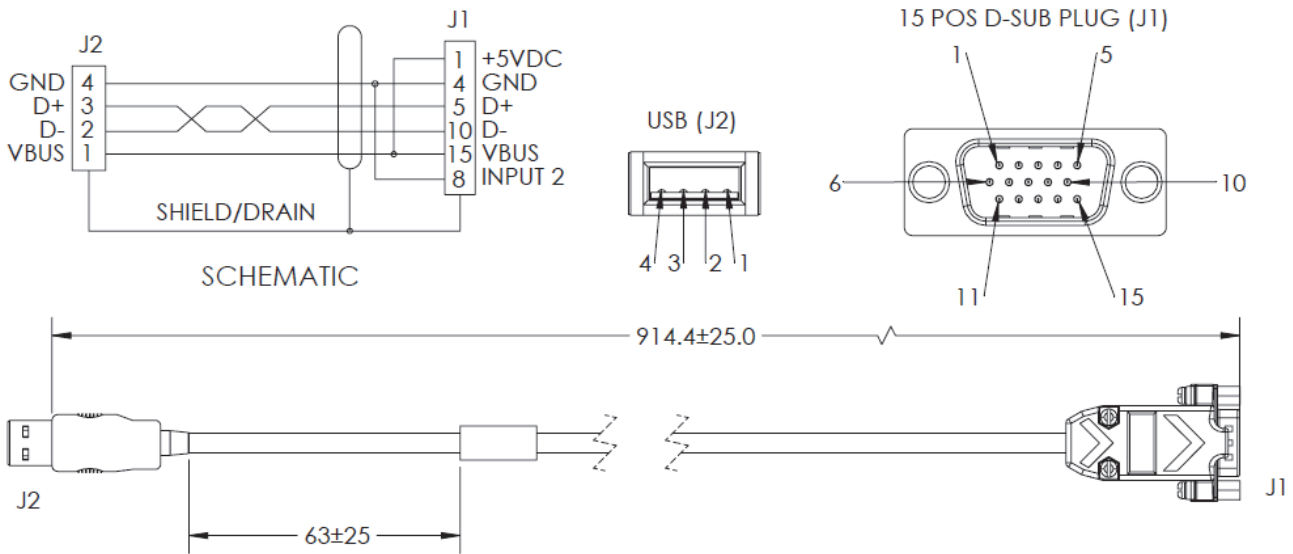

#### V420-WUX-1M – Cable – USB Breakout with External Power Input – 1 M

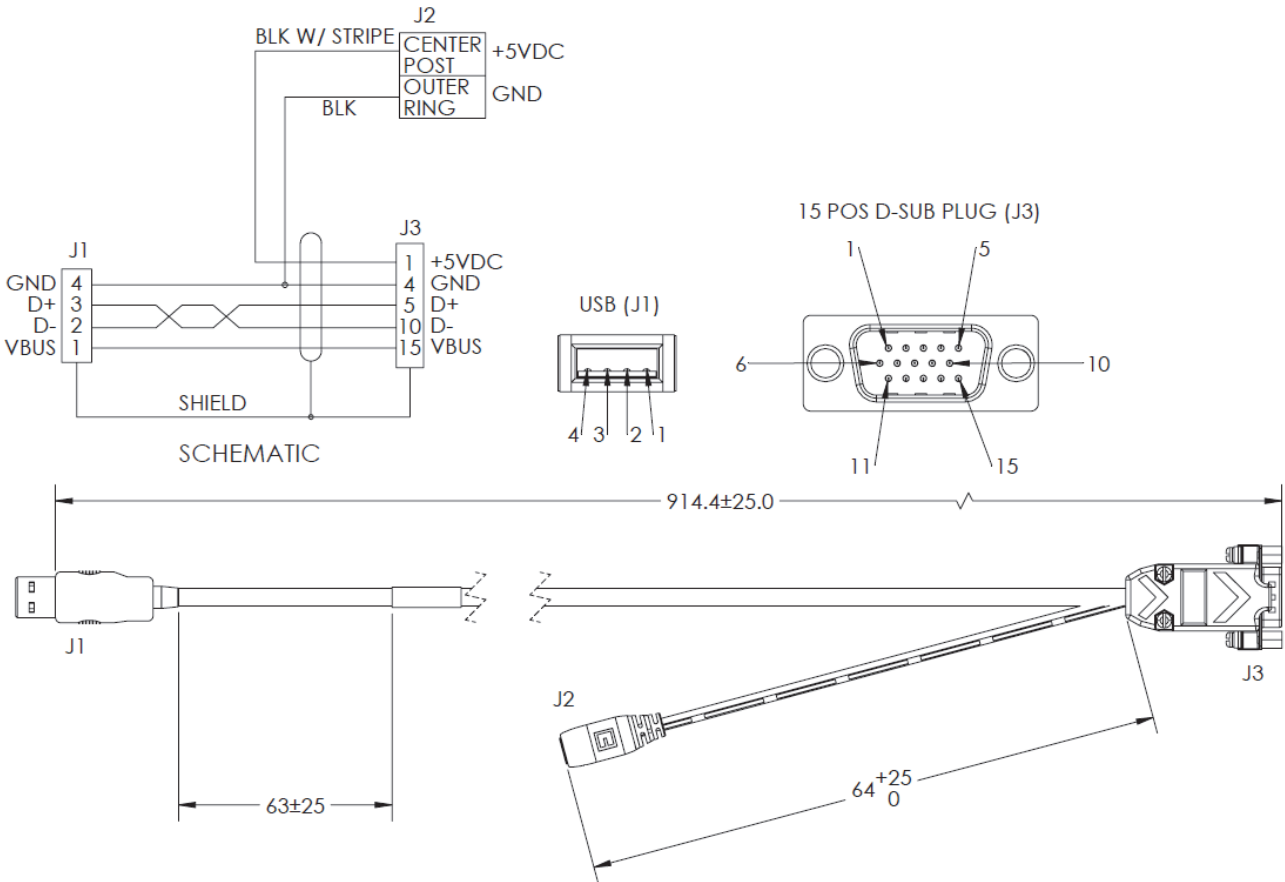

### V420-WRX-1M – Cable – RS-232 Breakout (DB-15) and External Power Input – 1 M

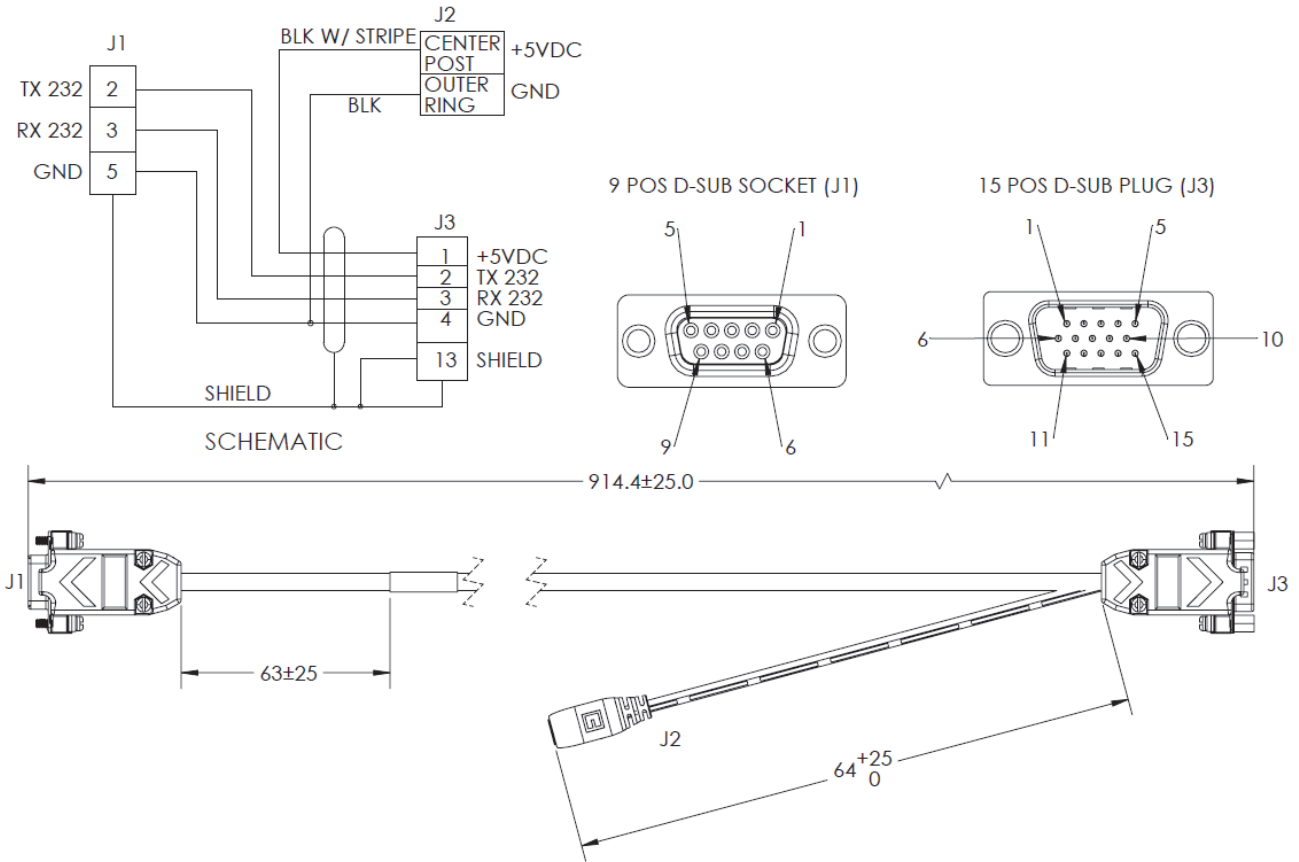

**A**

### V420-WU8X-1M – Cable – USB, IO, and Power Breakout – 1 M

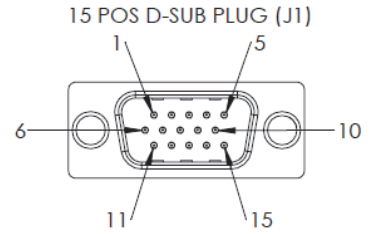
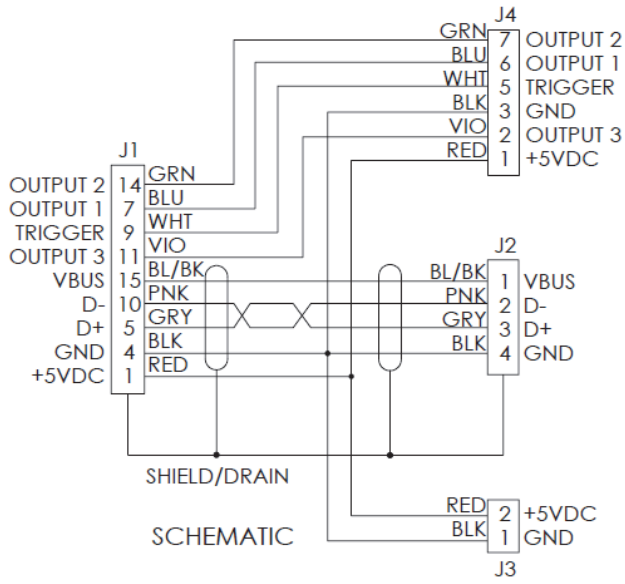

USB (J2)

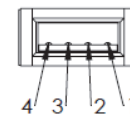

2 POS DIN PLUG (J3)

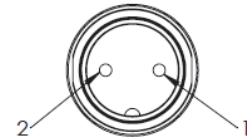

8 POS DIN SOCKET (J4)

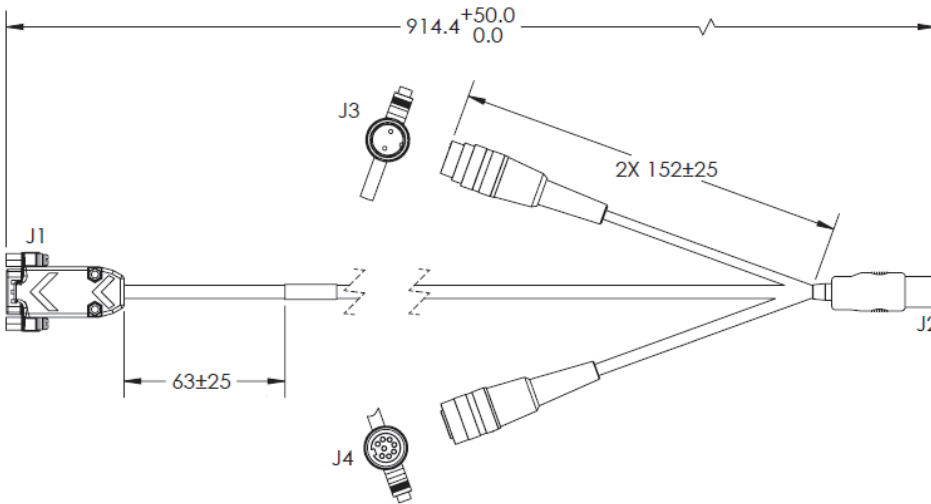
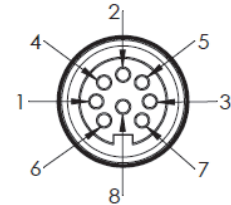



### V420-WRU8X-1M – Cable – RS-232, USB, IO, and Power Breakout – 1 M

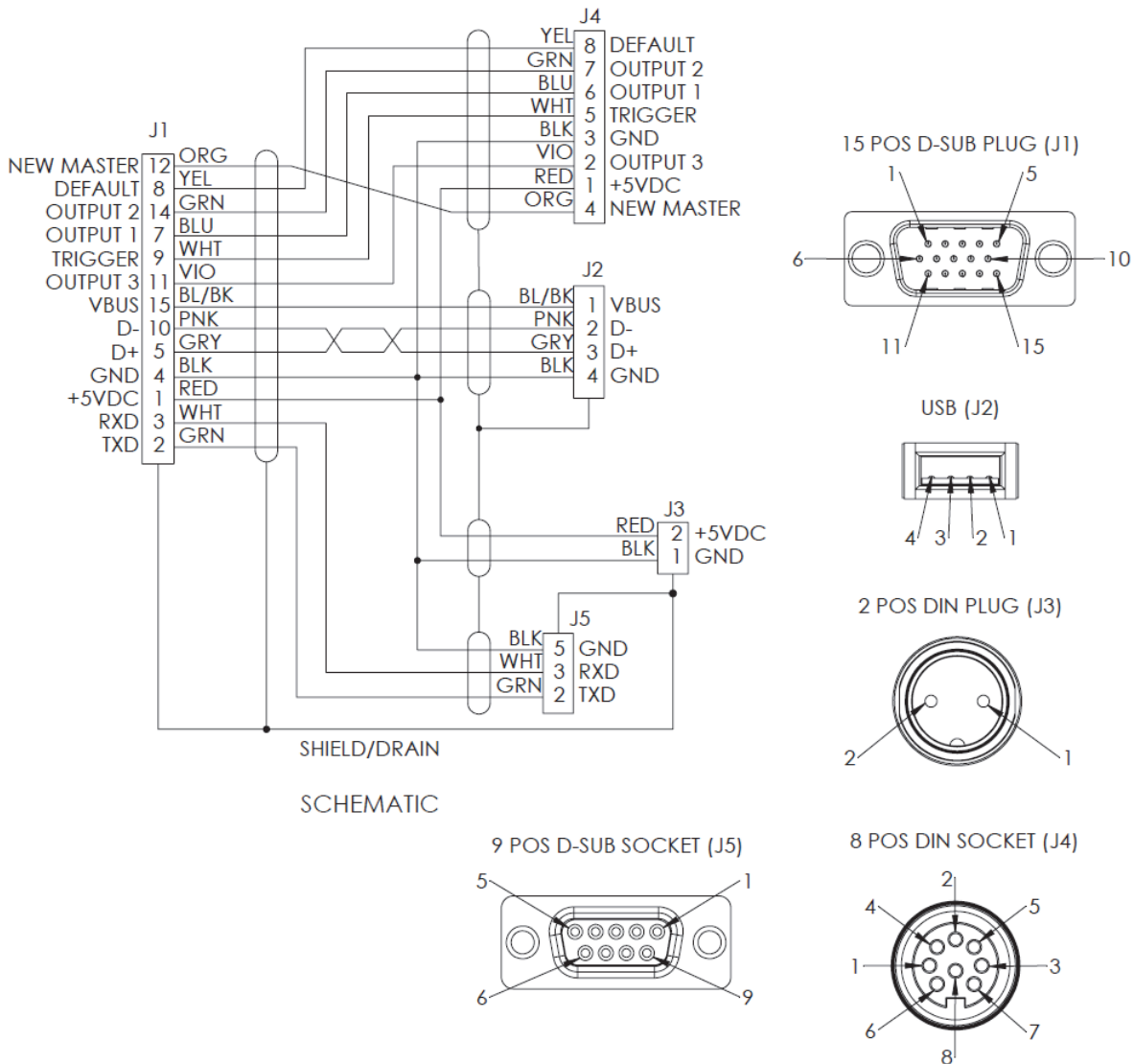

A

### 61-000151-01 – Cable – Trigger, IO and Power Breakout – 900 MM

Plugs into the IO connector on the V420-WU8X-1M and V420-WRU8X-1M cables.

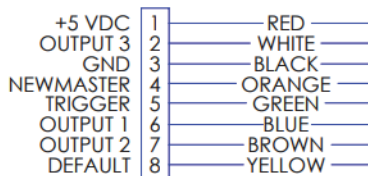

**CABLE SPECIFICATIONS**

8 CONDUCTOR STRANDED 22AWG  
UL LISTED  
PVC JACKET - BLACK OR GREY

**J1**

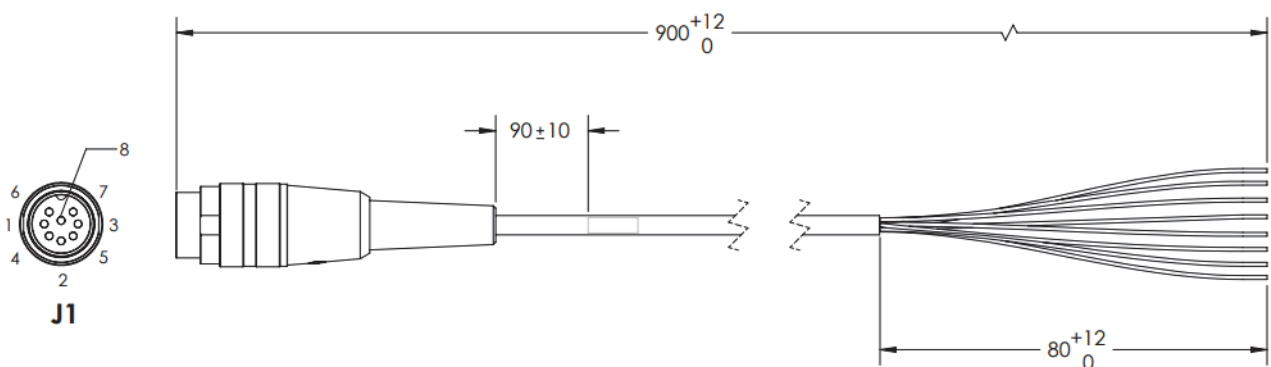

**A-3-11 MicroHAWK V430-F Cables with Pinouts and Wire Colors**

**V430-WE-1M – Ethernet Communication Cable, Straight Connector, M12 Plug on Camera to RJ45 Connector – 1 M**

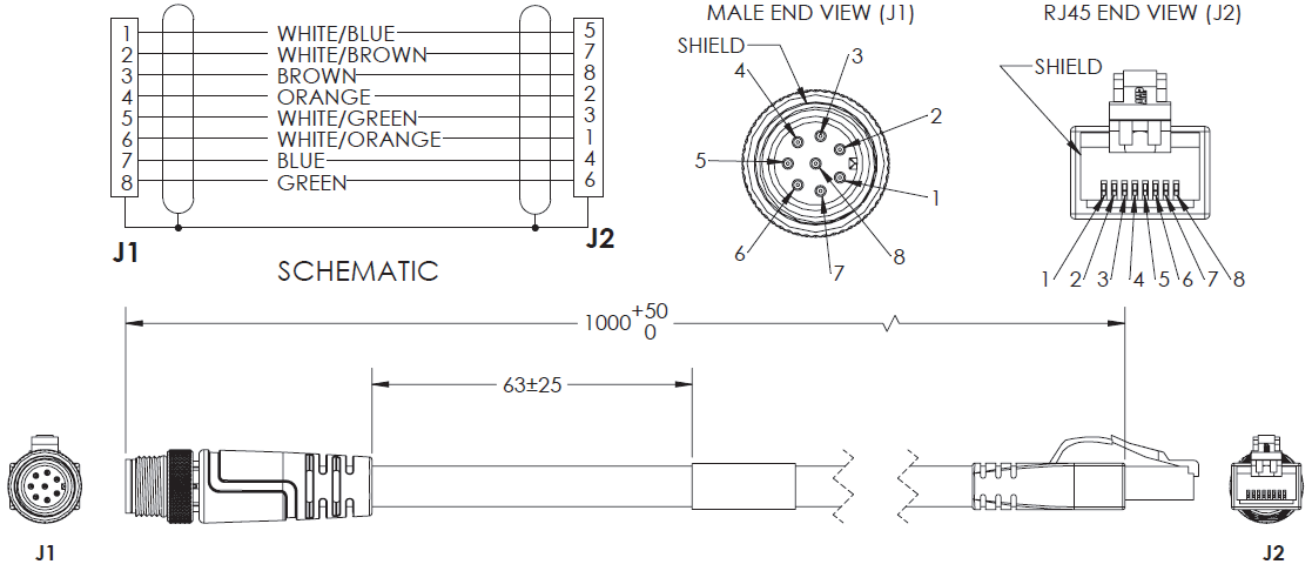

**V430-WE-3M – Ethernet Communication Cable, Straight Connector, M12 Plug on Camera to RJ45 Connector – 3 M**

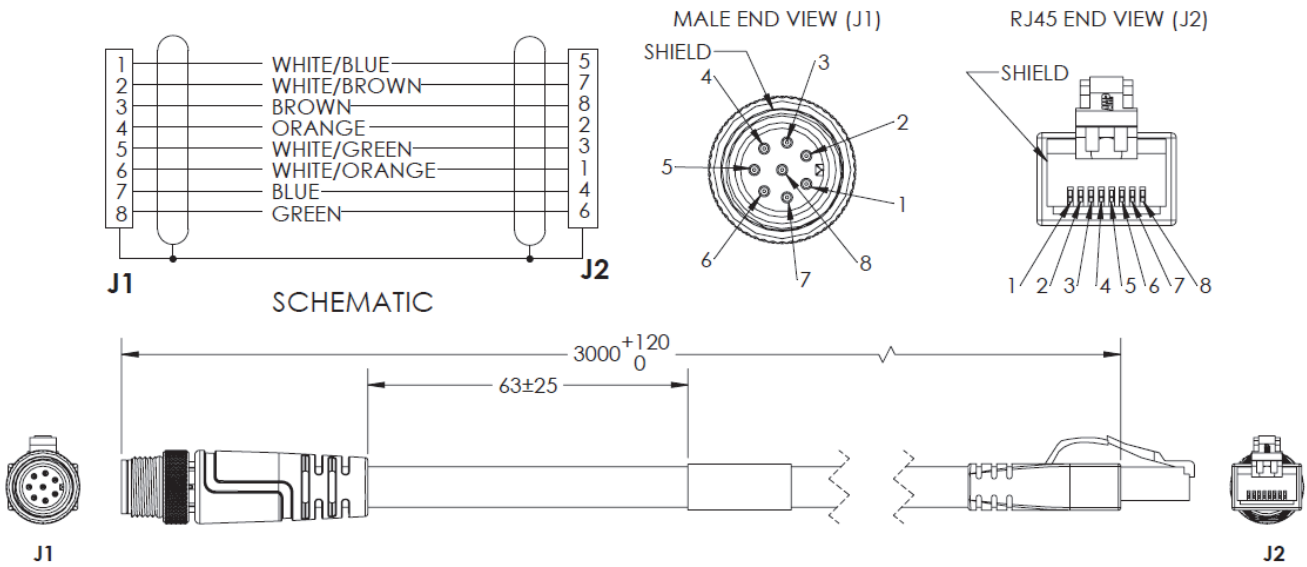

### V430-WE-5M – Ethernet Communication Cable, Straight Connector, M12 Plug on Camera to RJ45 Connector – 5 M

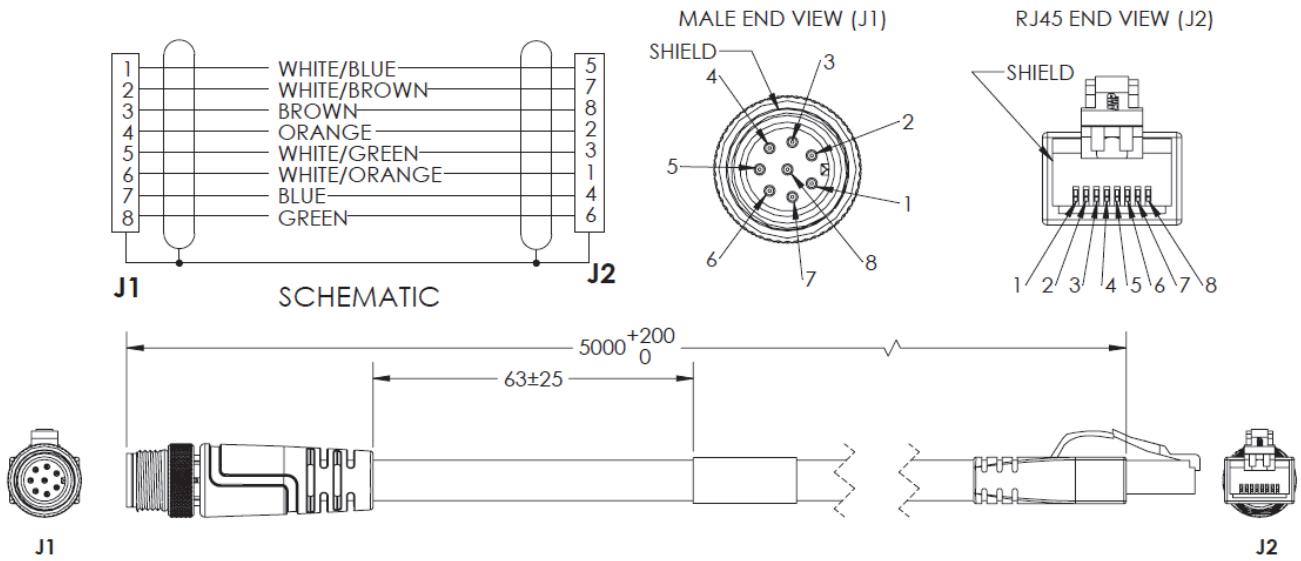

### V430-WELU-3M – Ethernet Communication Cable, Right Angle Up\* Connector, M12 Plug on Camera to RJ45 – 3 M

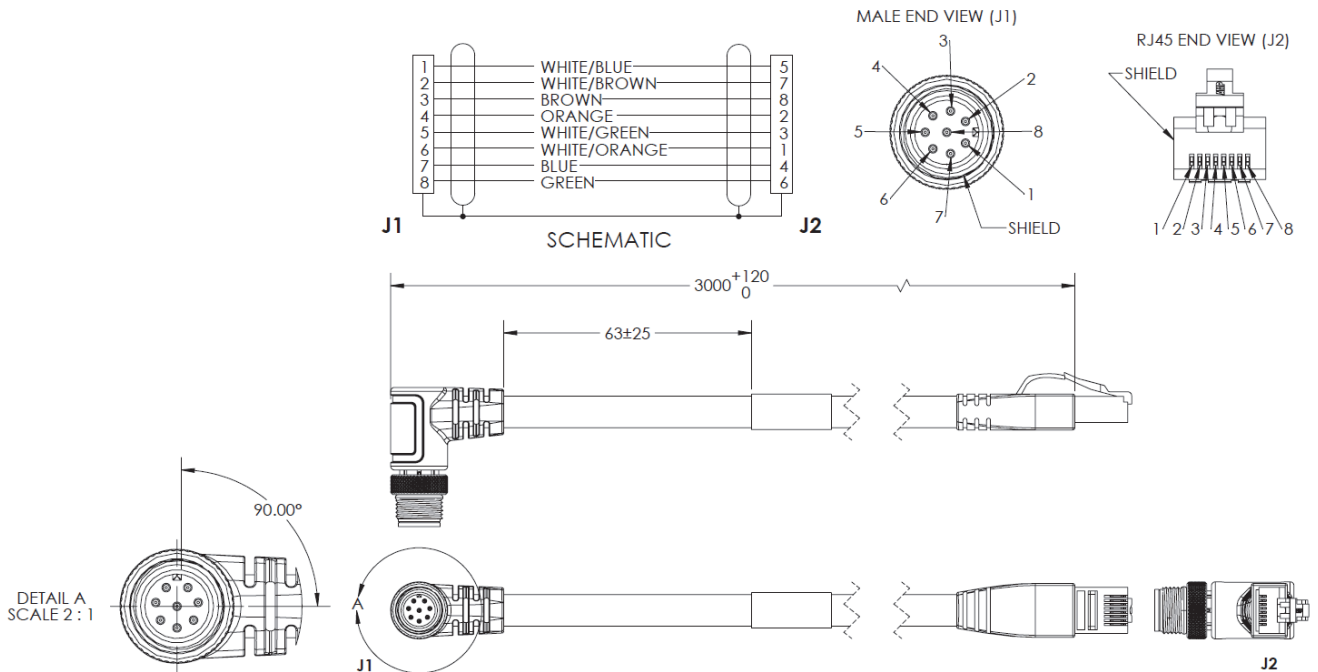

\*Right angle up



### V430-WELD-3M – Ethernet Communication Cable, Right Angle Down\* Connector, M12 Plug on Camera to RJ45 – 3 M

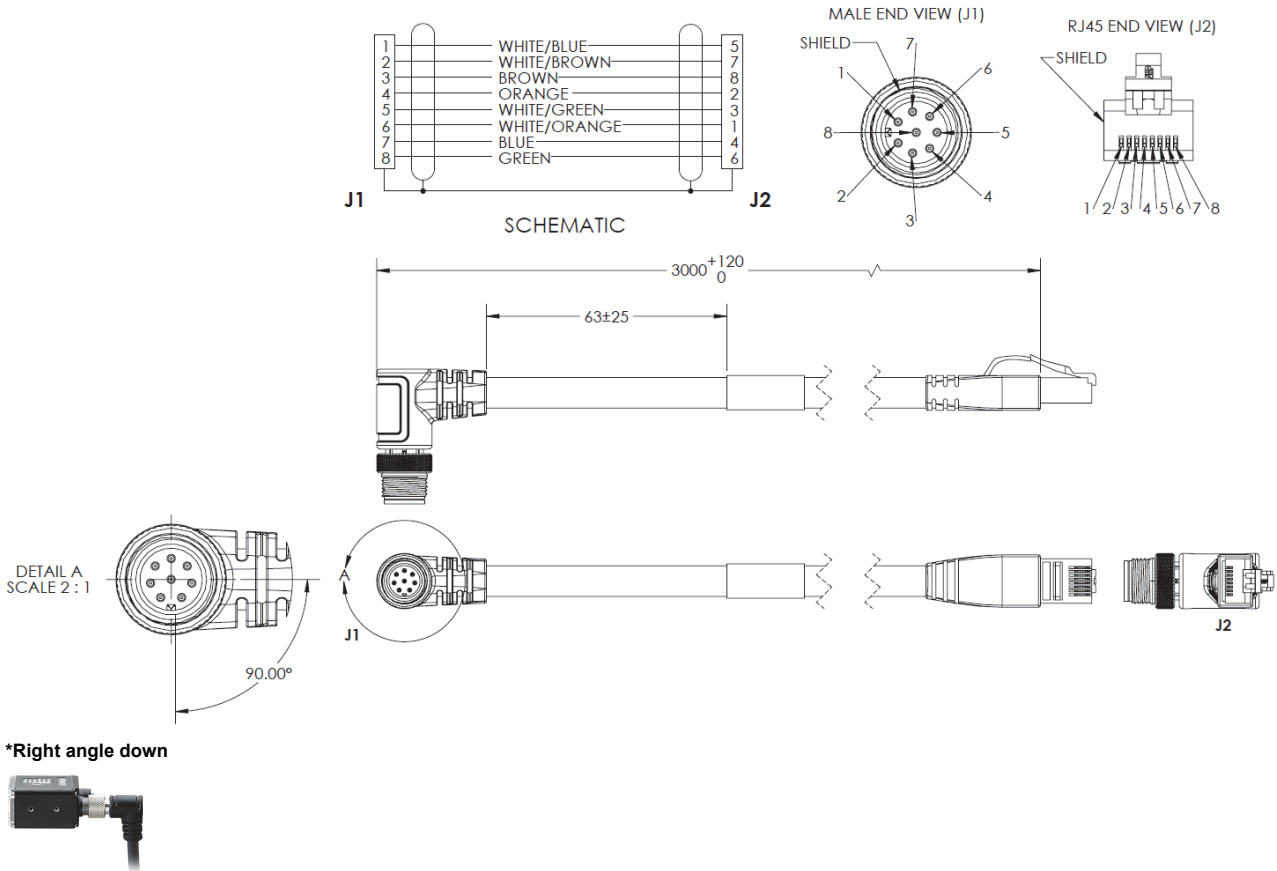

### V430-WQ-1M – Camera to QX-1 Interconnect Cable, M12 Socket to M12 Plug – 1 M

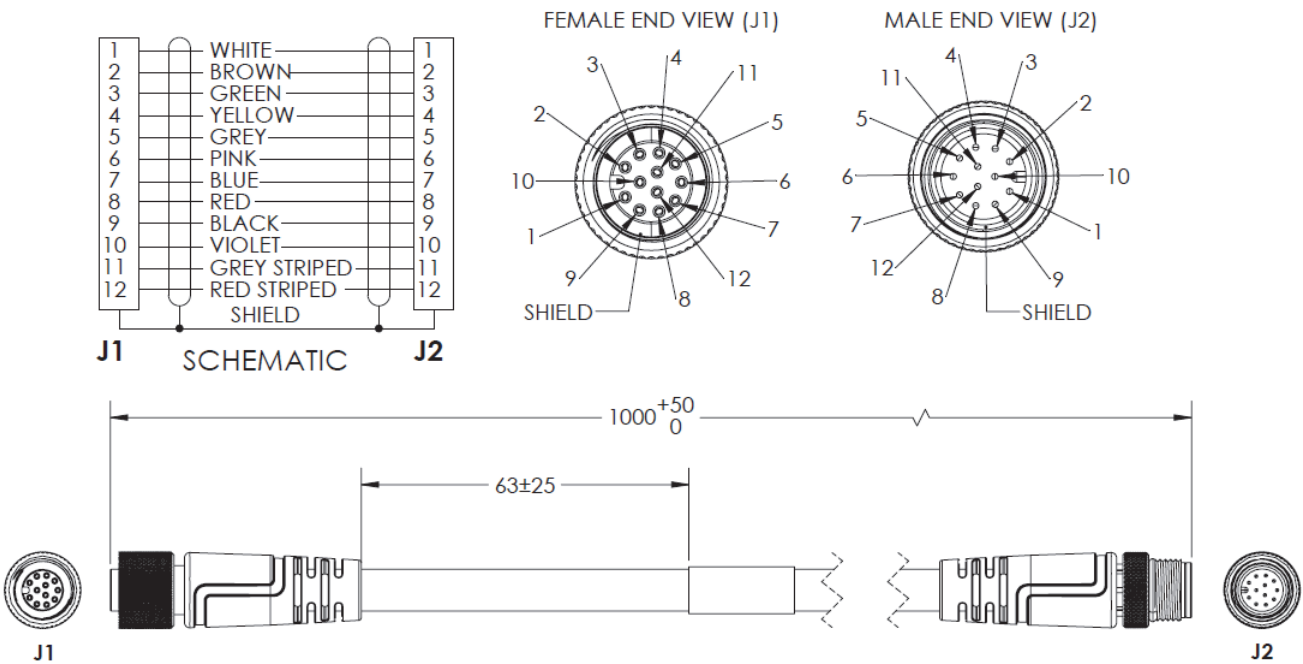

### V430-WQF-1M – Camera to QX-1 Interconnect Cable, M12 Socket to M12 Plug, with Power Filter – 300 MM

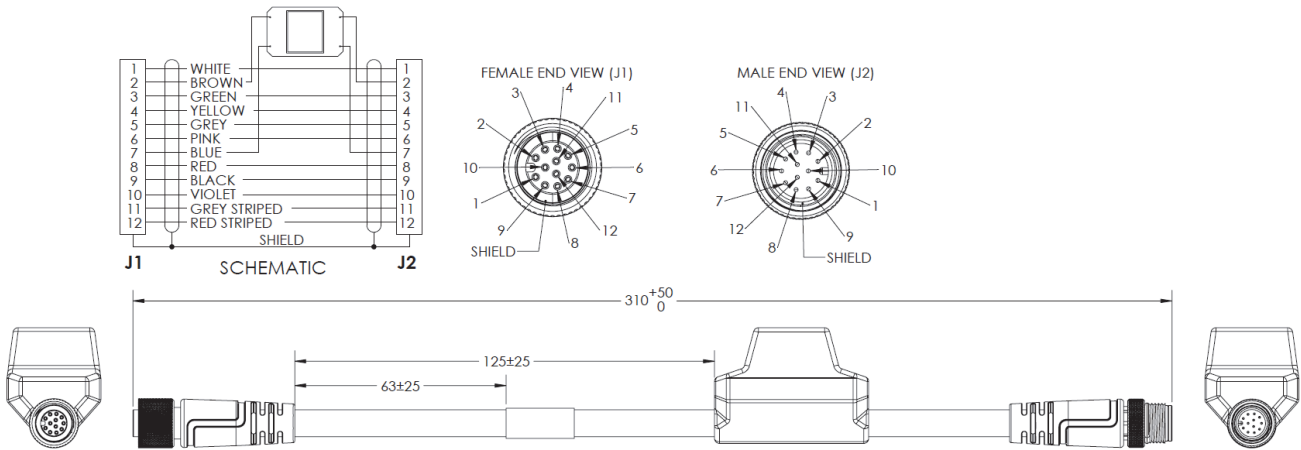

A

### V430-WQ-3M – Camera to QX-1 Interconnect Cable, M12 Socket to M12 Plug – 3 M

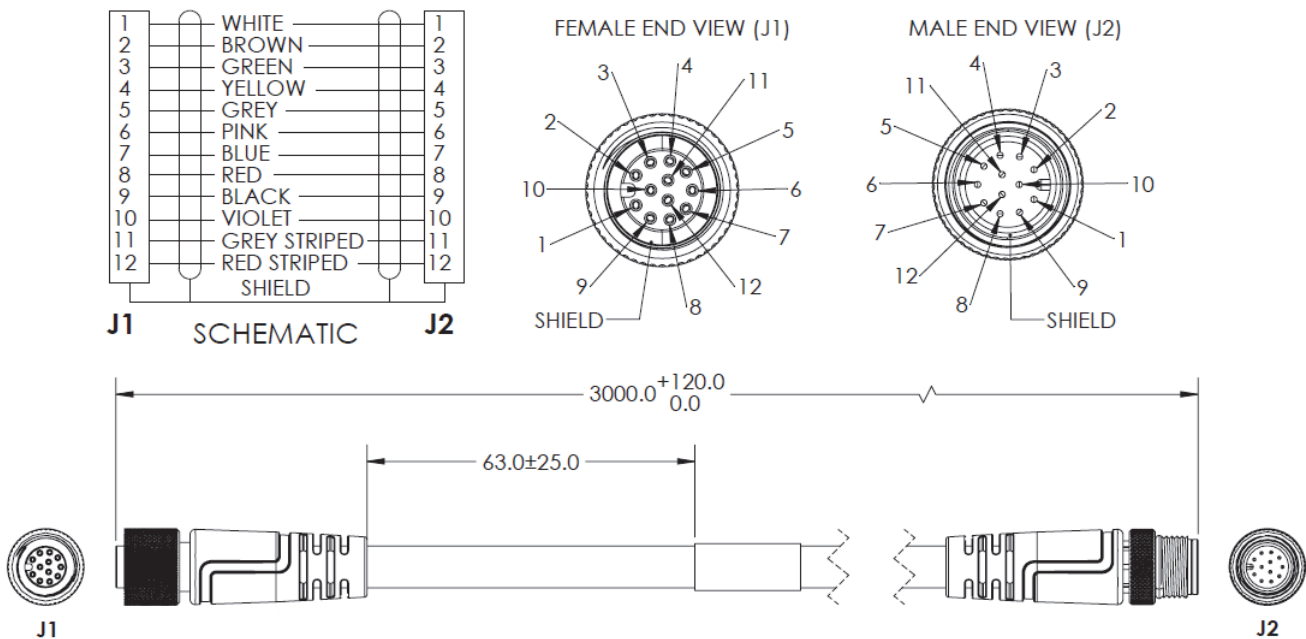

### V430-WQ-5M – Camera to QX-1 Interconnect Cable, M12 Socket to M12 Plug – 5 M

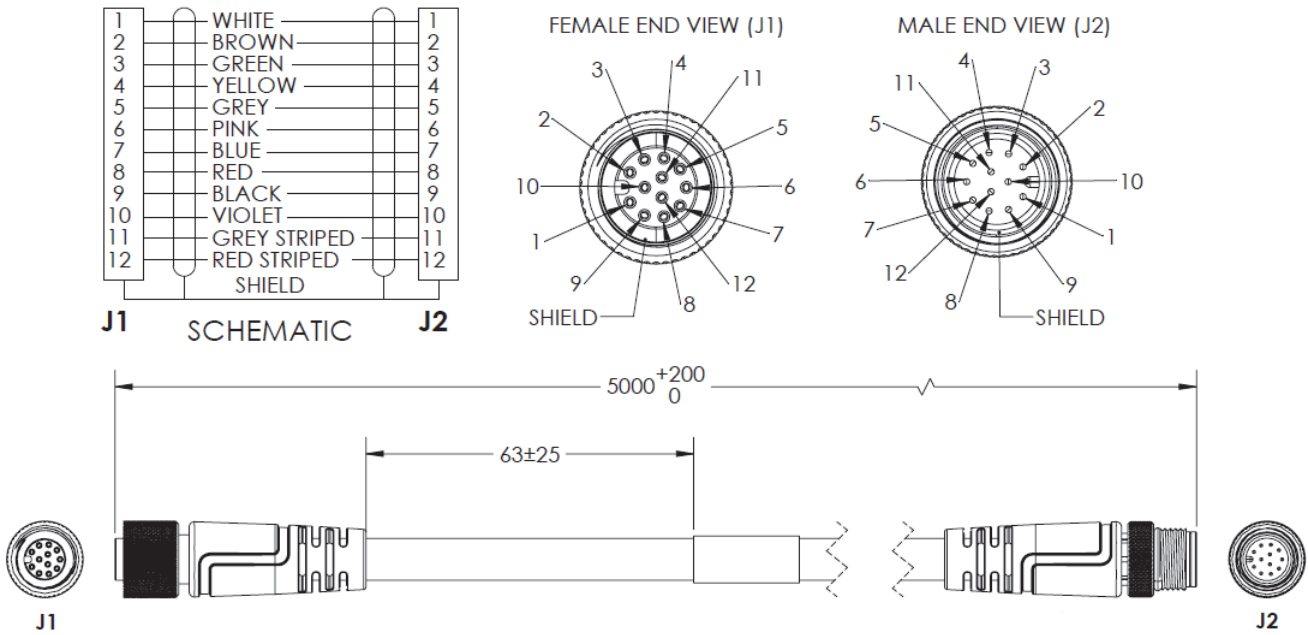

### 61-000204-01 – QX-1 to Smart Light, M12 Plug on QX-1 to 5-Pin Socket on Light, Continuous Power – 3 M

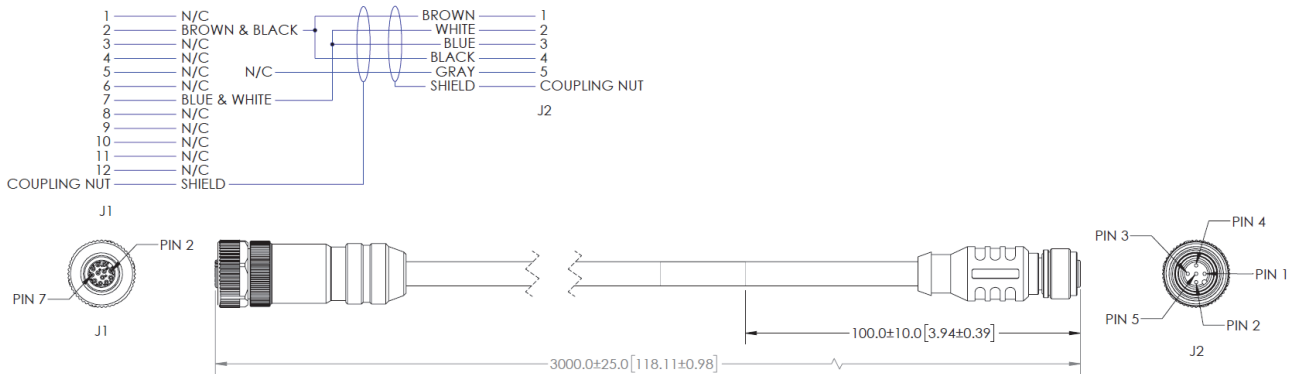

### 61-000218-01 – QX-1 to Smart Light, M12 Plug on QX-1 to 5-Pin Socket on Light, Strobe Control – 3 M

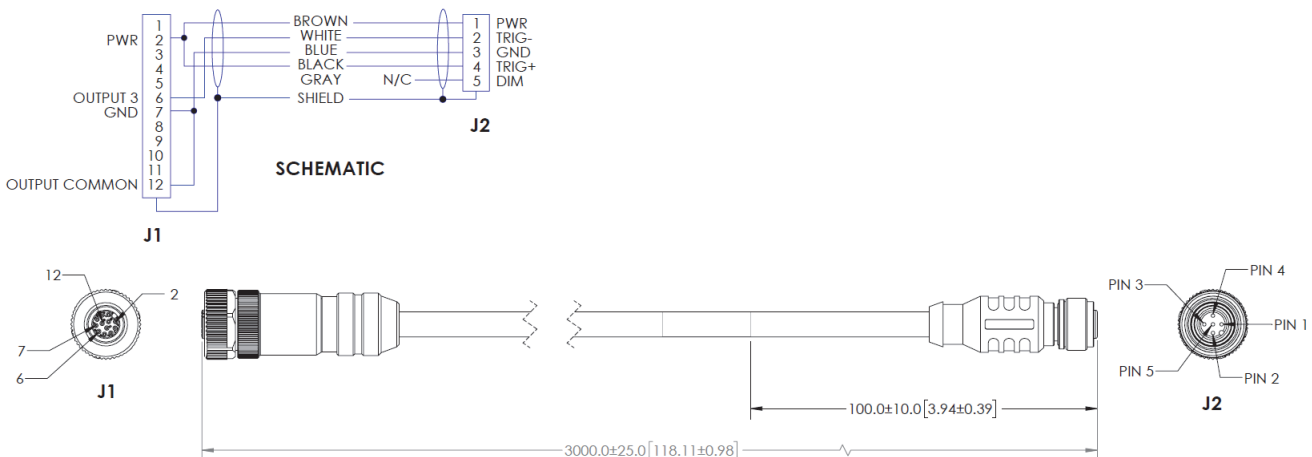

**61-9000135-01 – Y Cable, Camera / Power and Smart Light Power (Continuous On) – 1 M**

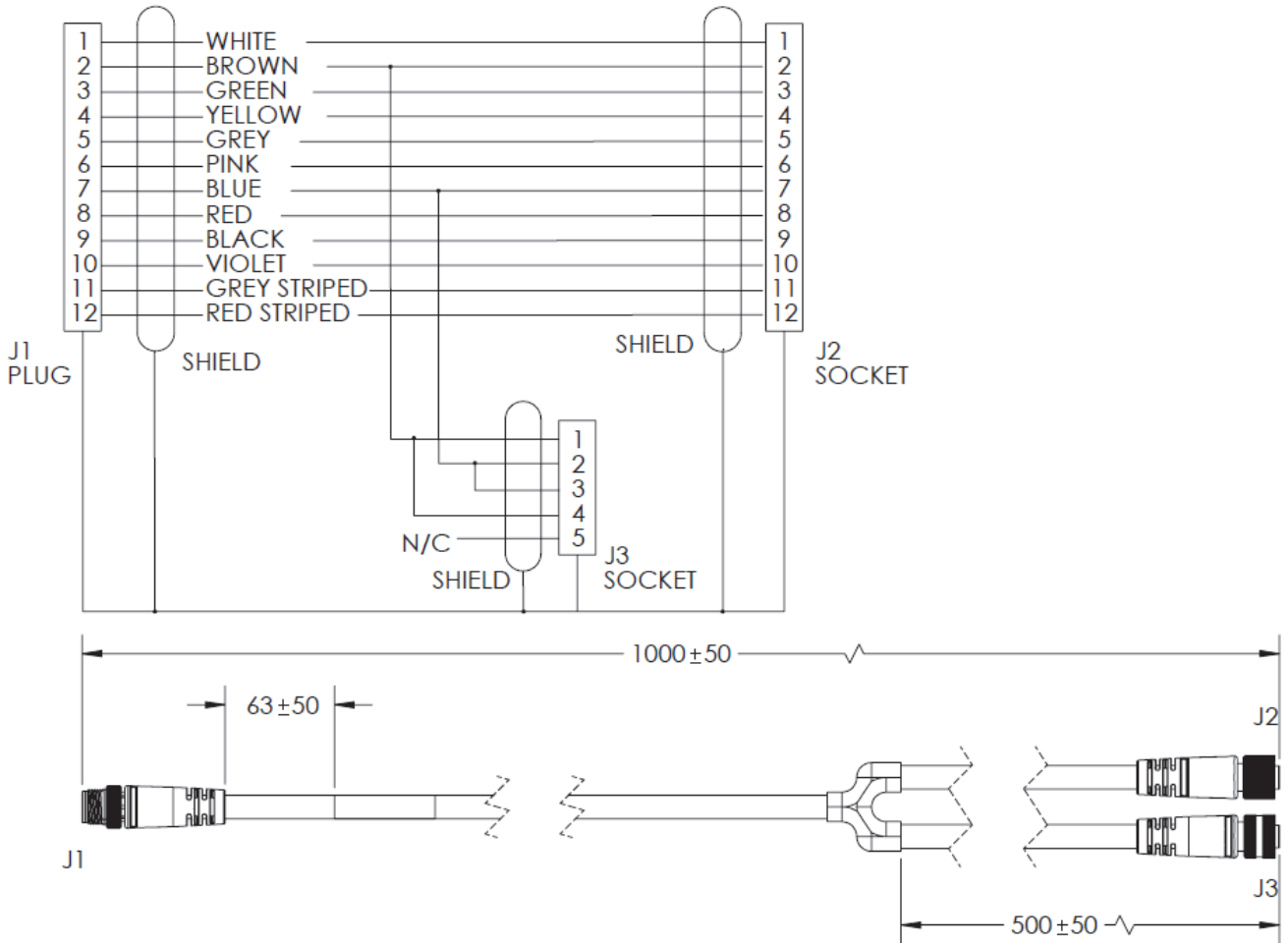

A

### 61-9000137-01 – Y Cable, Camera / Power and Smart Light Strobe Control – 1 M

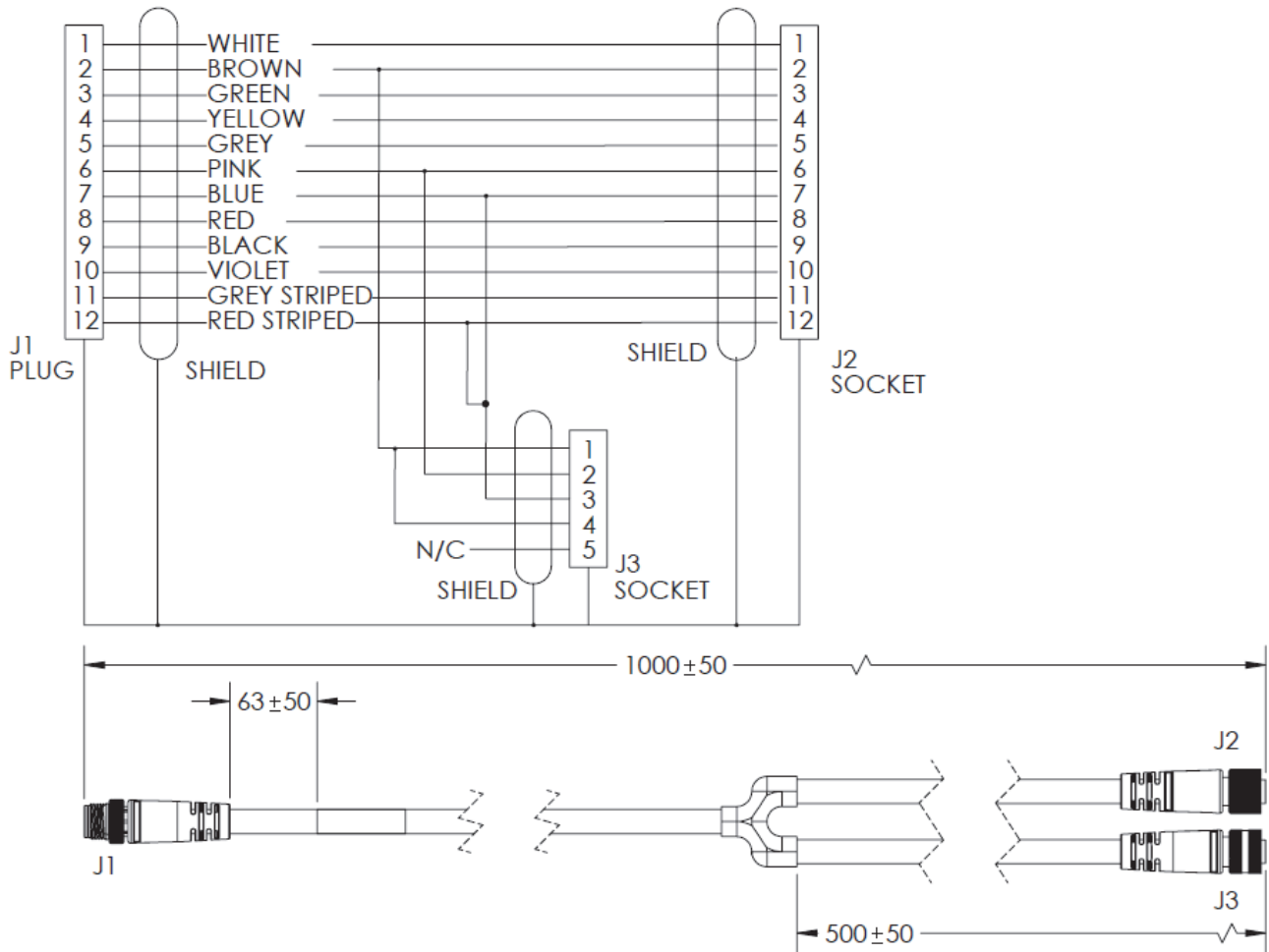

### V430-W8-3M – M12 to Flying Leads Cable, Straight Power, IO, RS-232, USB – 3 M

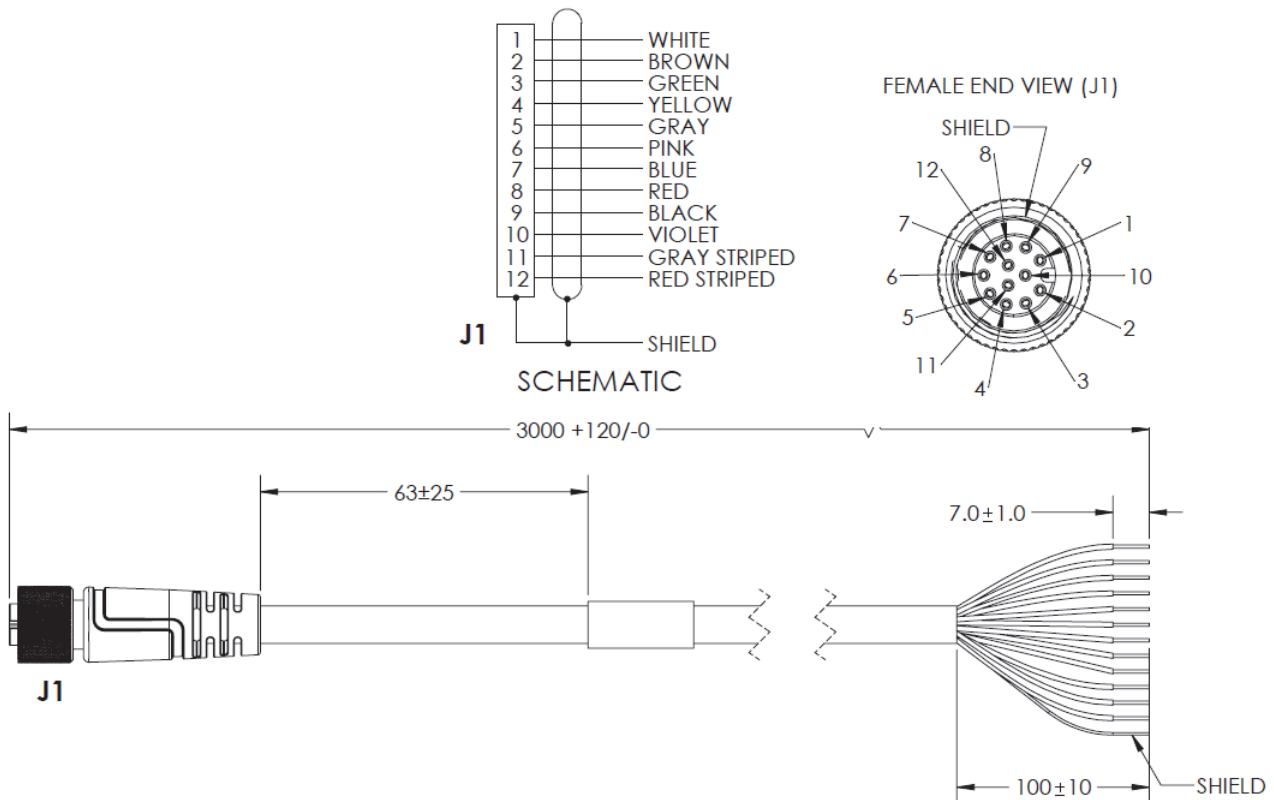



### V430-W8F-3M – M12 to Flying Leads Cable, with Power Filter – 3 M

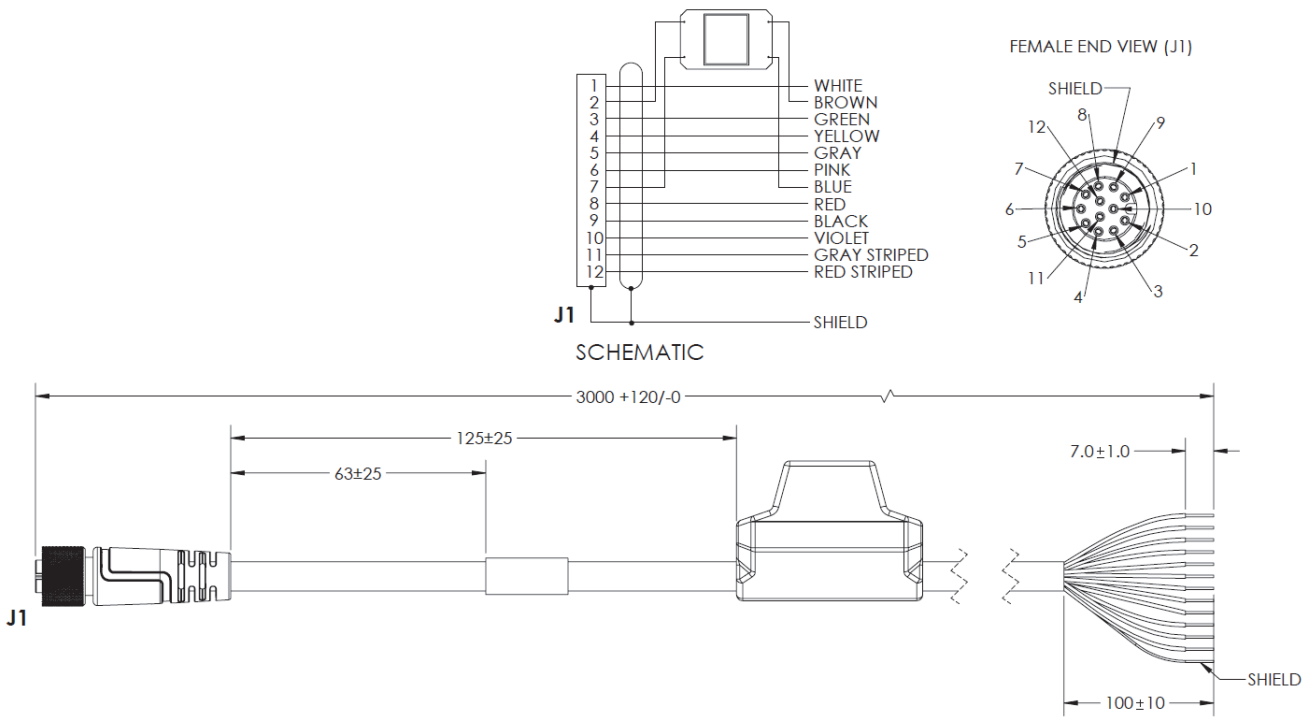

A

### V430-W8-5M – M12 to Flying Leads Cable, Straight Power, IO, RS-232, USB – 5 M

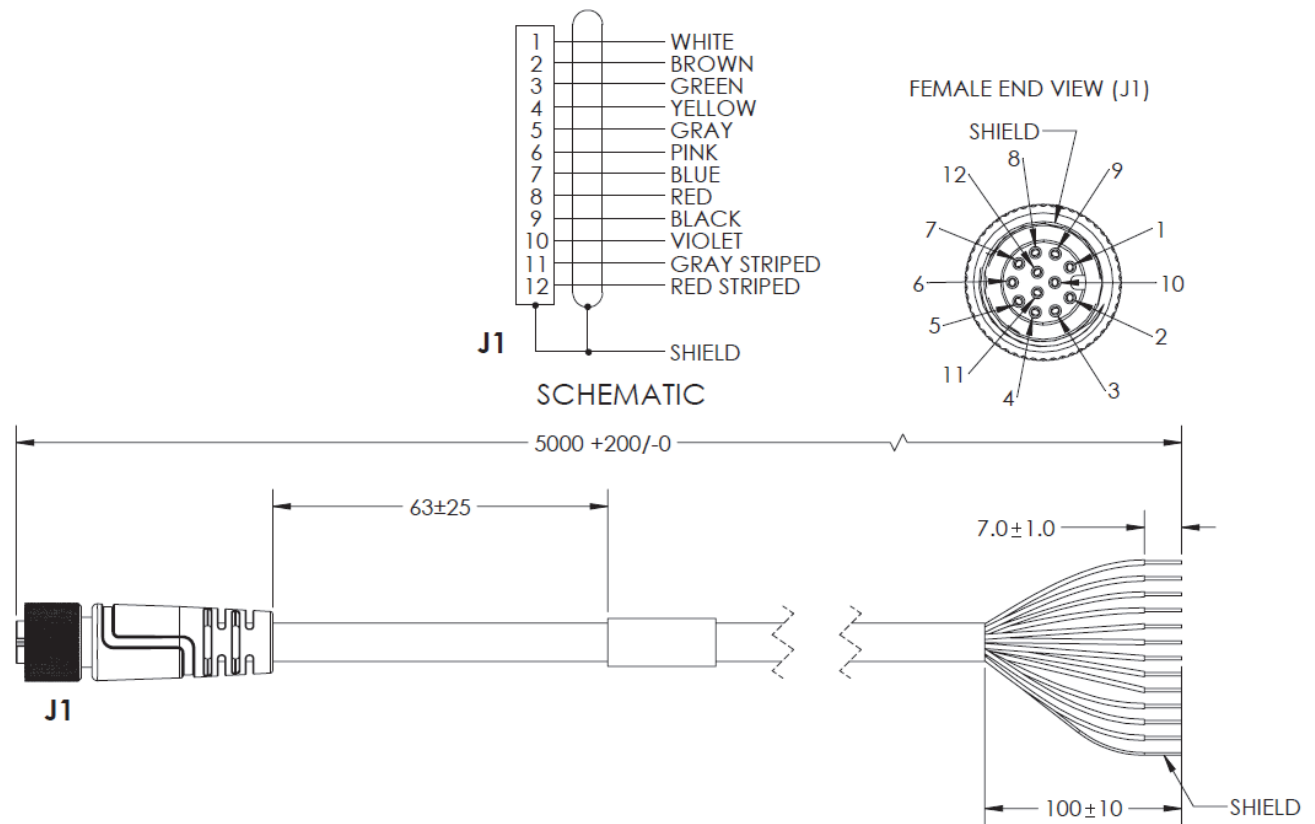

### V430-W8F-5M – M12 to Flying Leads Cable, with Power Filter – 5 M

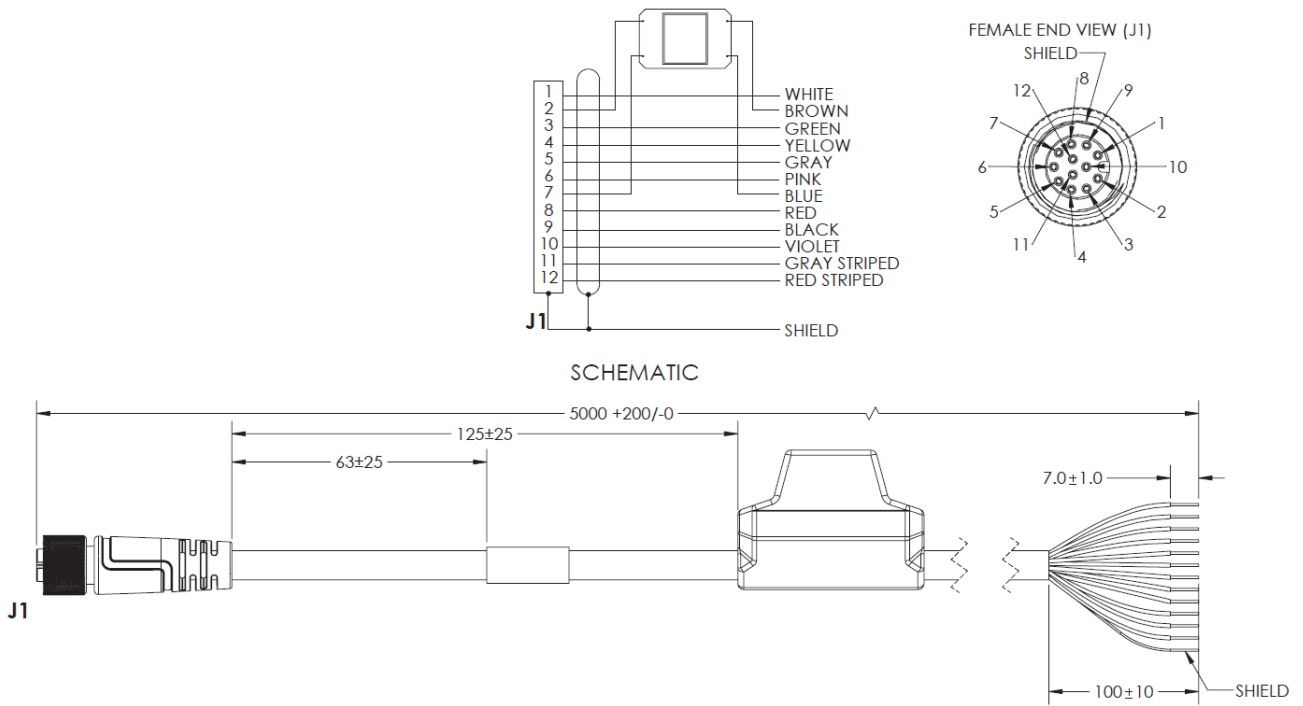

### V430-W8LU-3M – M12 to Flying Leads Cable, Right Angle Up\* Power, IO, RS-232, USB – 3 M

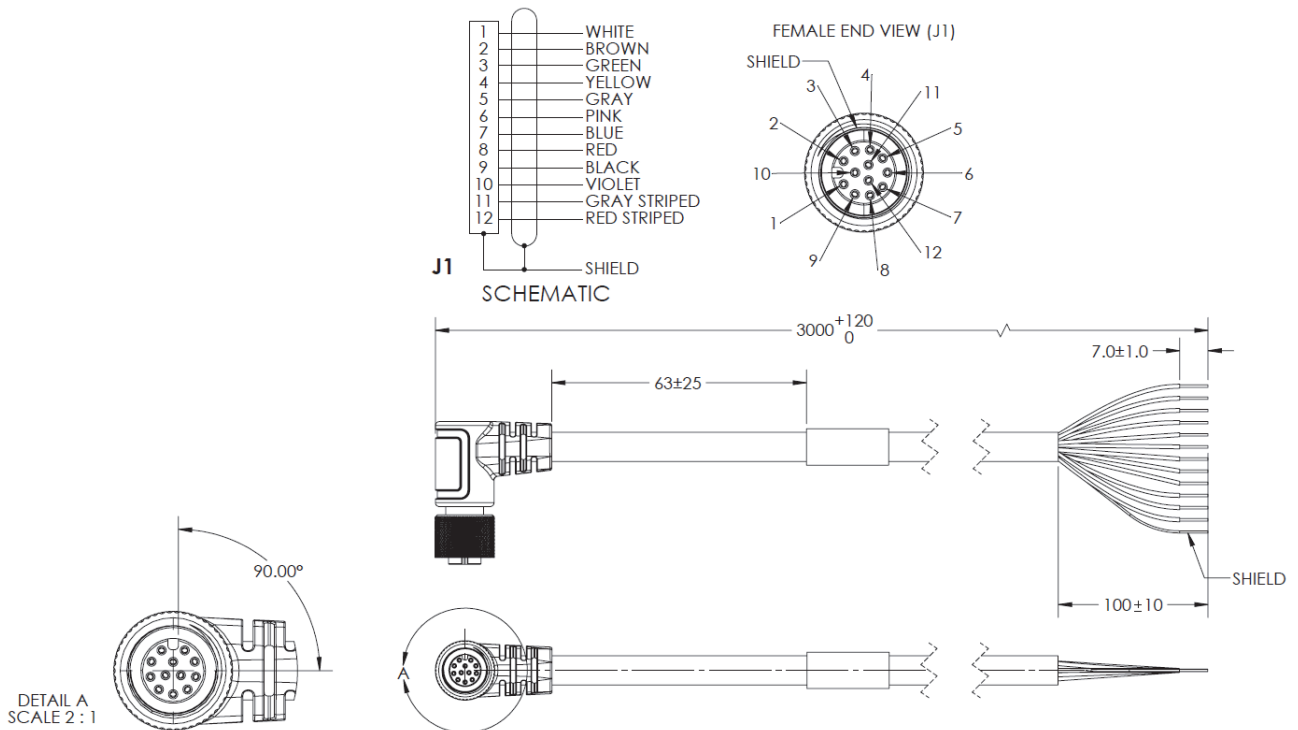

\*Right angle up



### V430-W8LUF-3M – M12 to Flying Leads Cable, Right Angle Up\*, with Power Filter – 3 M

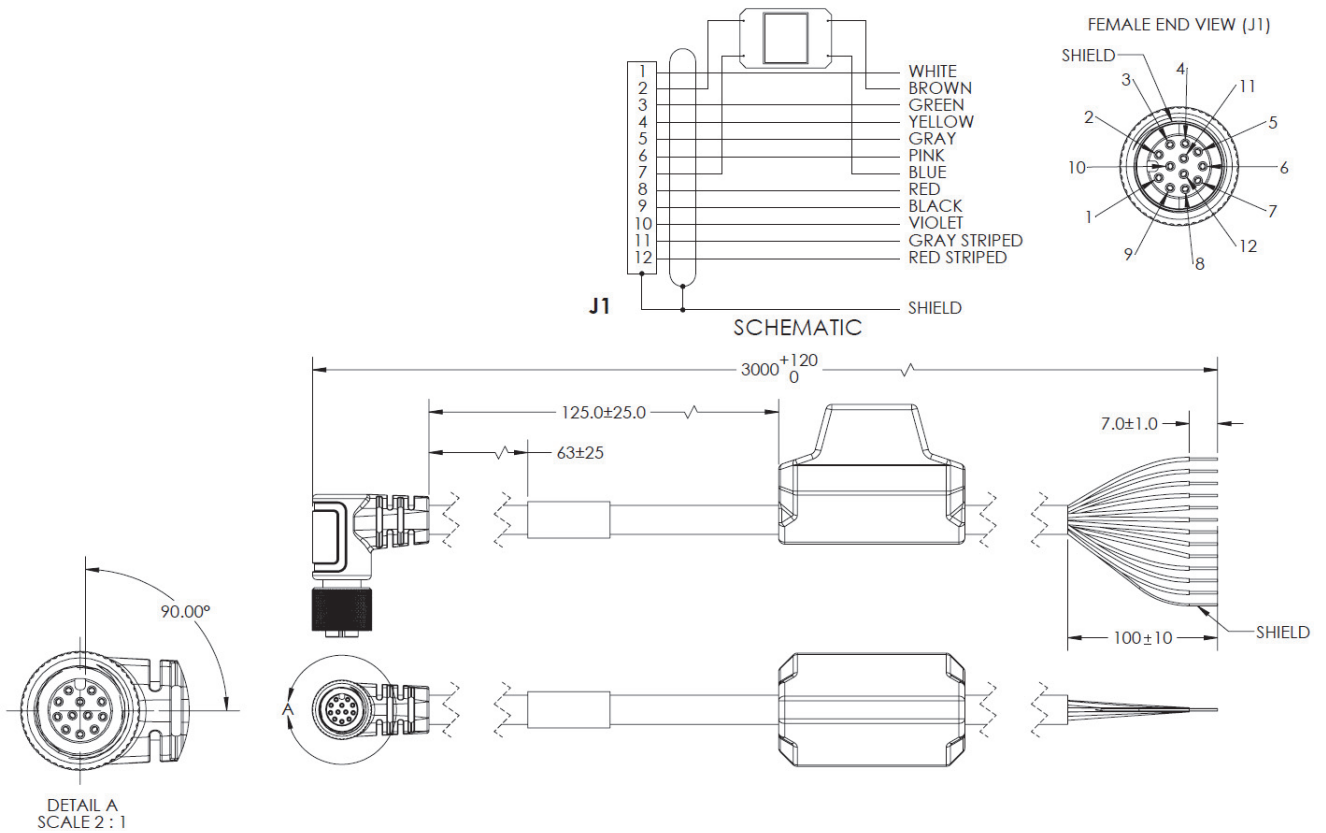

\*Right angle up



### V430-W8LD-3M – M12 to Flying Leads Cable, Right Angle Down\*, Power, IO, RS-232, USB – 3 M

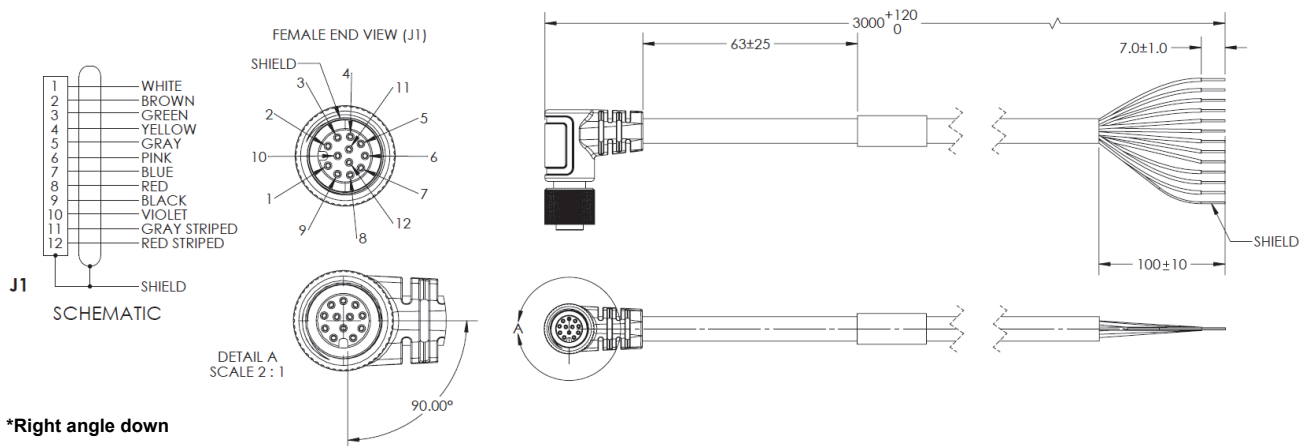

\*Right angle down



### V430-W8LDF-3M – M12 to Flying Leads Cable, Right Angle Down\*, with Power Filter – 3 M

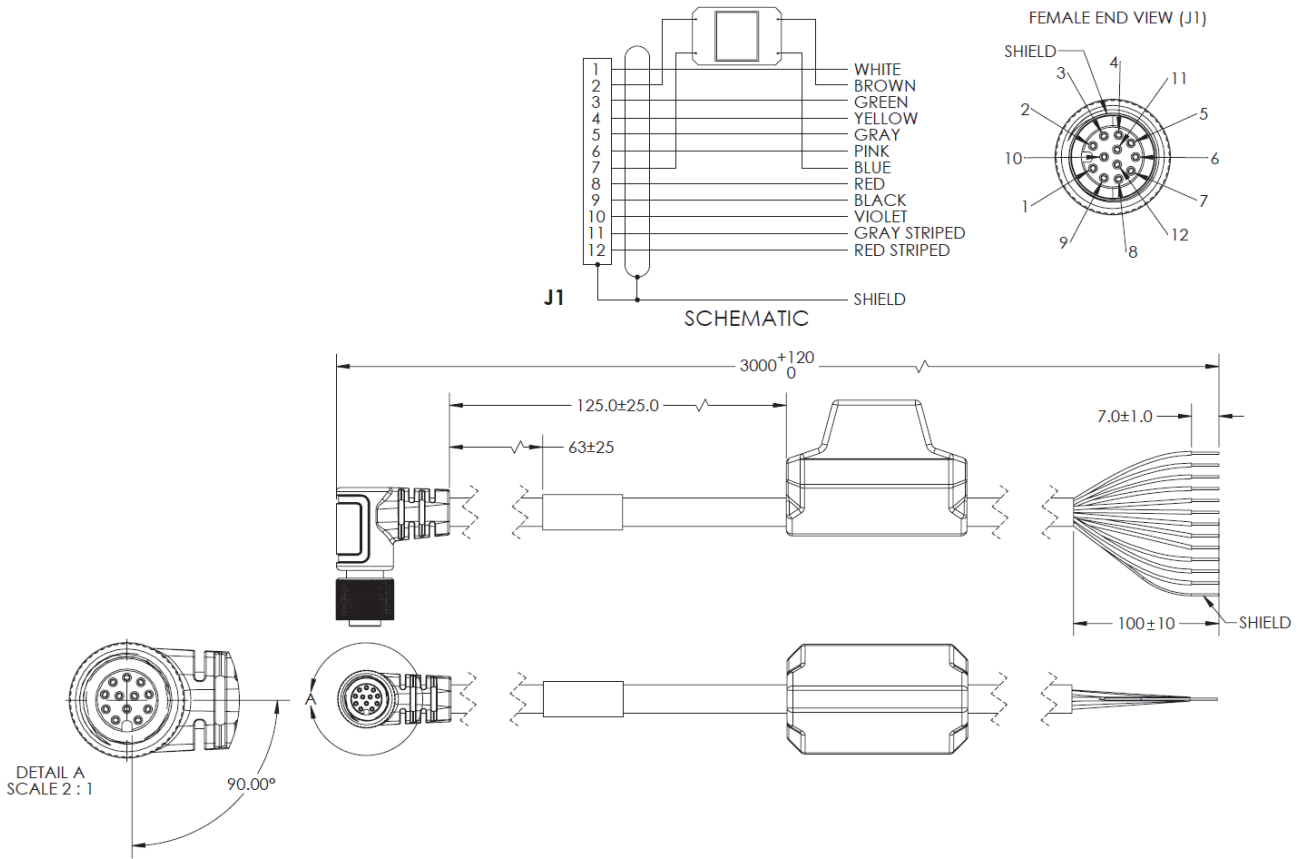

\*Right angle down



### V430-WR-1M – M12 to RS-232 Breakout – 1 M

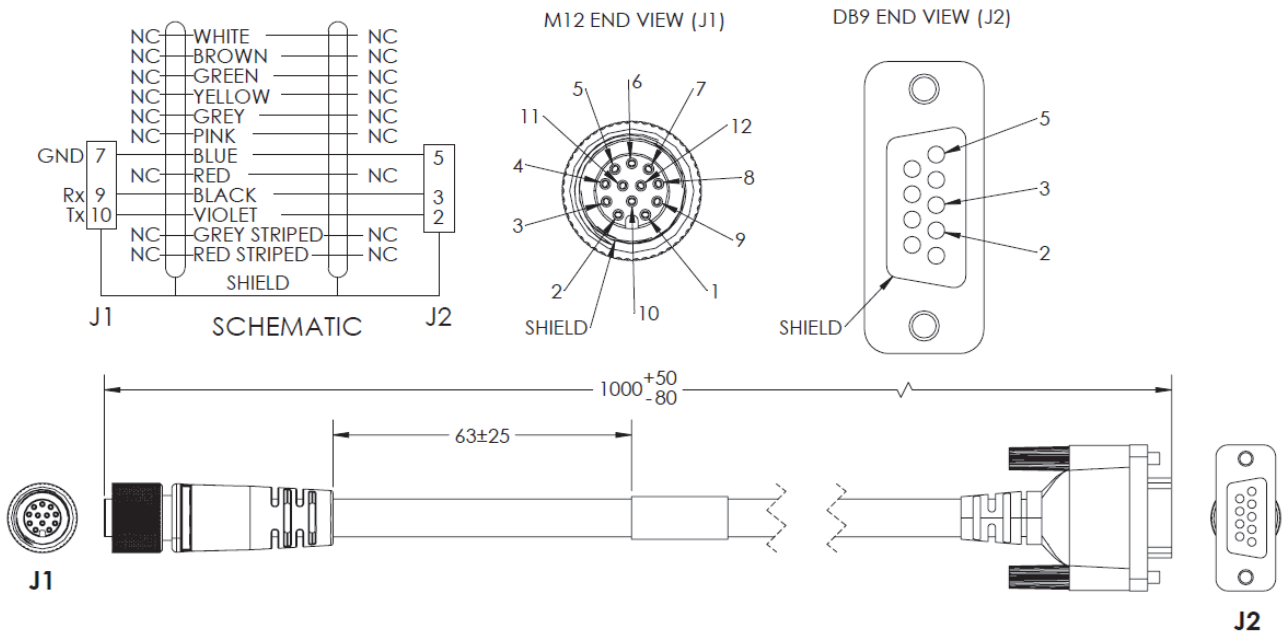

### V430-WR-3M – M12 to RS-232 Breakout – 3 M

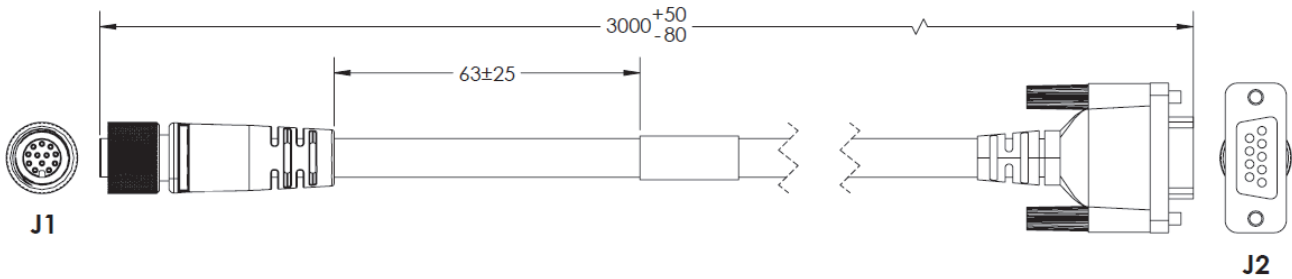
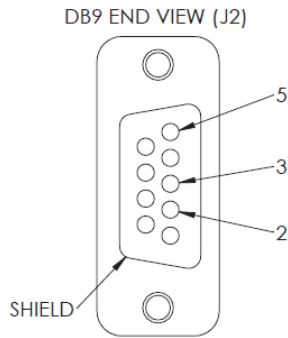
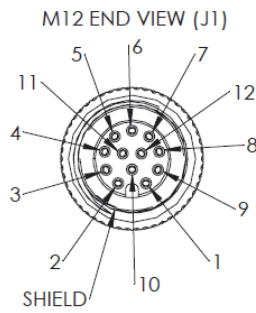
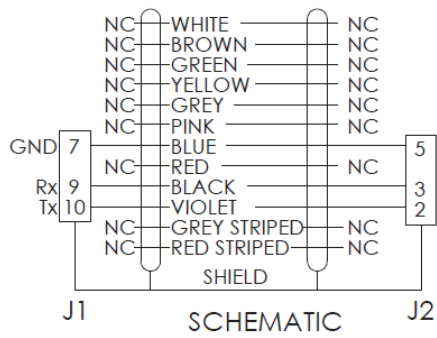

**A**

### V430-WQR-3M – Camera to QX-1 Interconnect Cables with RS-232 Breakout – 2.7 M

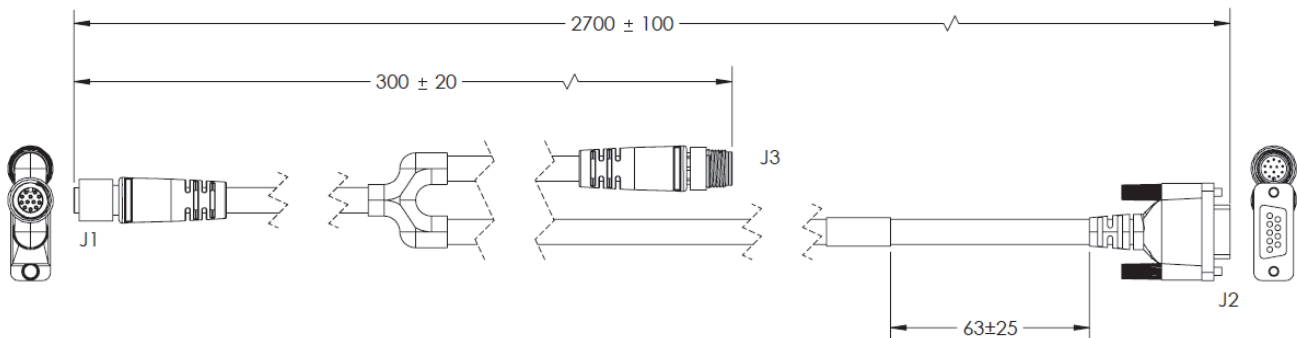
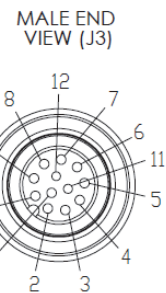
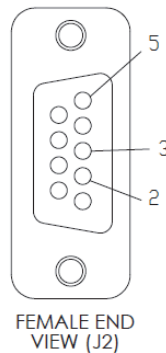
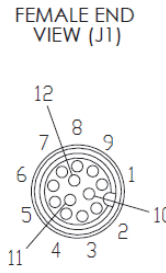
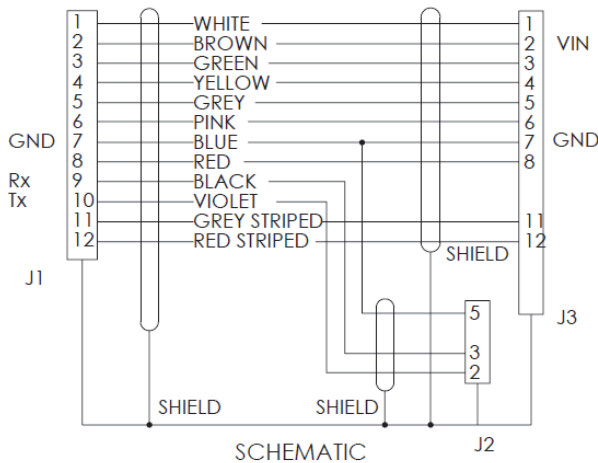

## V430-WQK-3M – Camera to QX-1 Interconnect Cables with USB Keyboard Wedge Breakout – 2.7 M

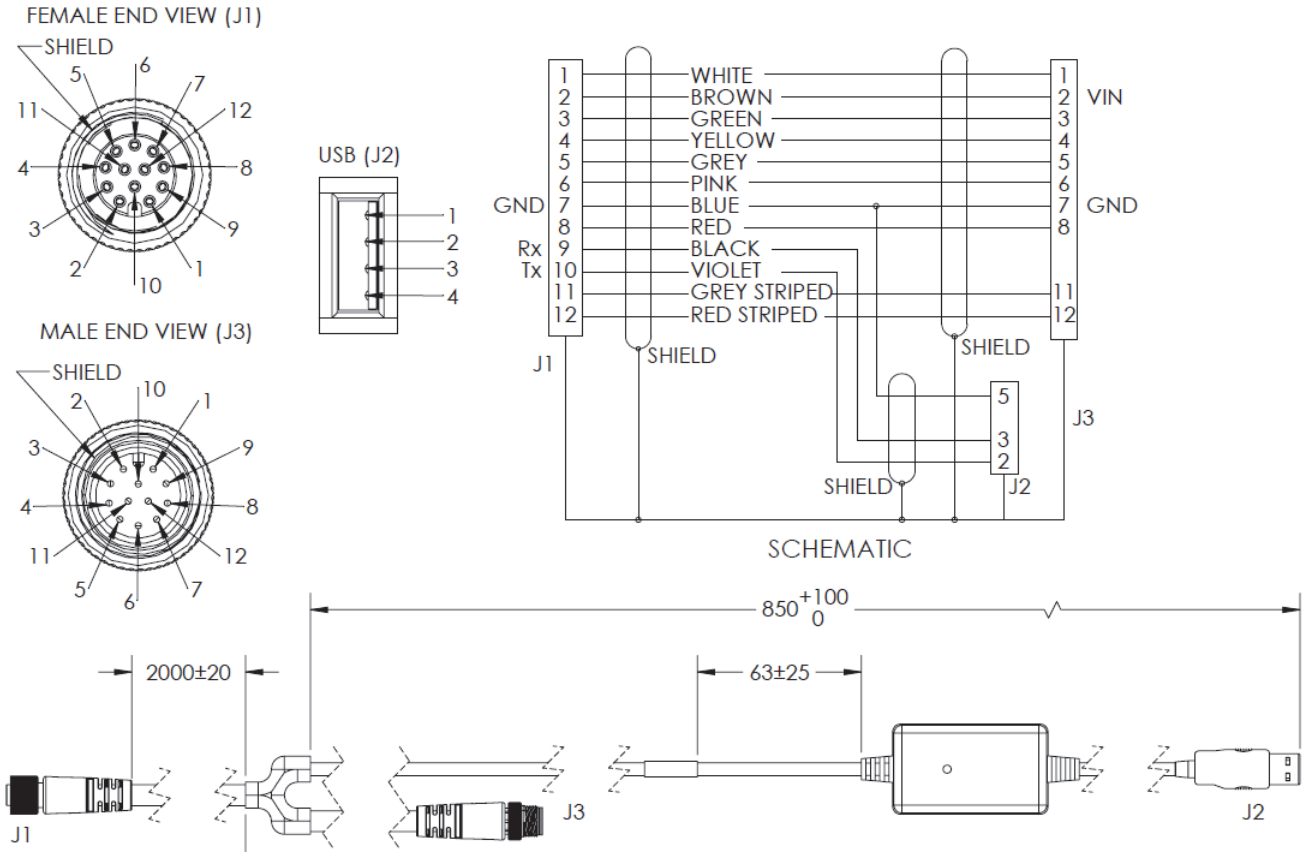

## 61-000148-03 – M12 12-Pin Plug to M12 12-Pin Socket, Right Angle, 3 M

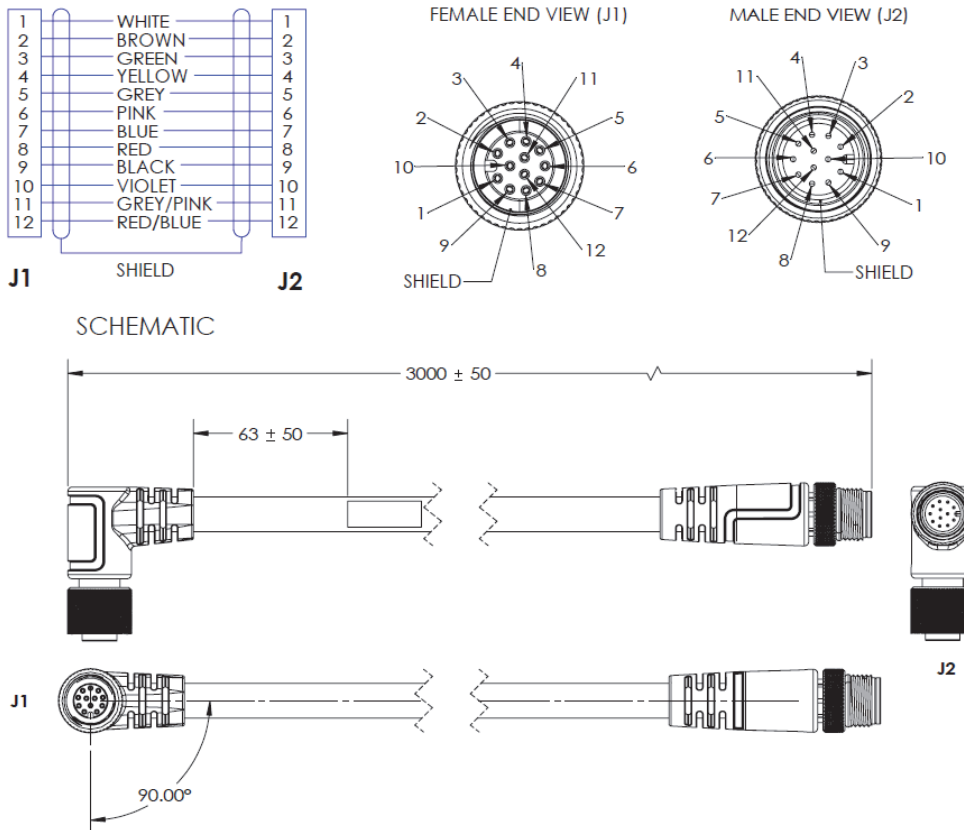

### 61-000148-04 – M12 12-Pin Plug to M12 12-Pin Socket, Right Angle, Alternate Key, 3 M

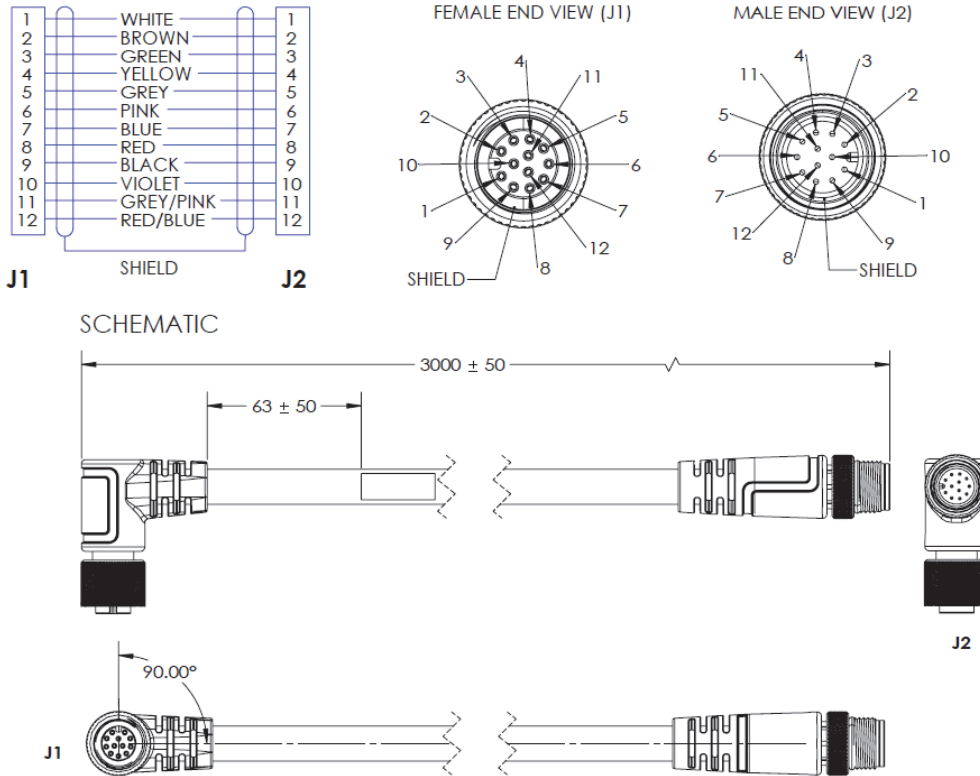

A

### 61-000162-03 – M12 12-Pin Plug to M12 12-Pin Socket, Right Angle, 1 M

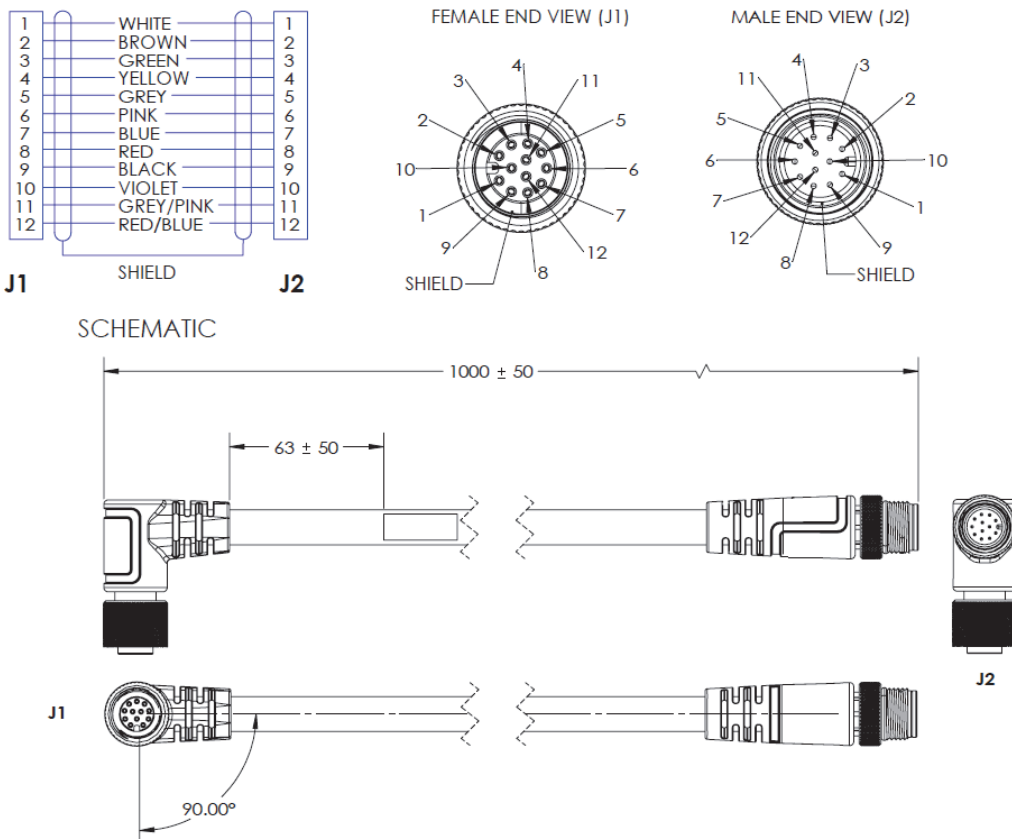

### 61-000162-04 – M12 12-Pin Plug to M12 12-Pin Socket, Right Angle, Alternate Key, 1 M

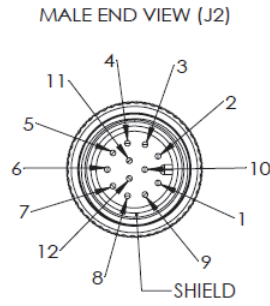
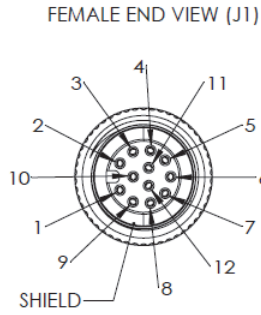
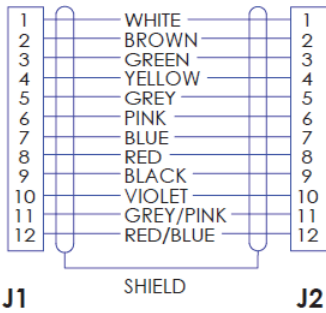

SCHEMATIC

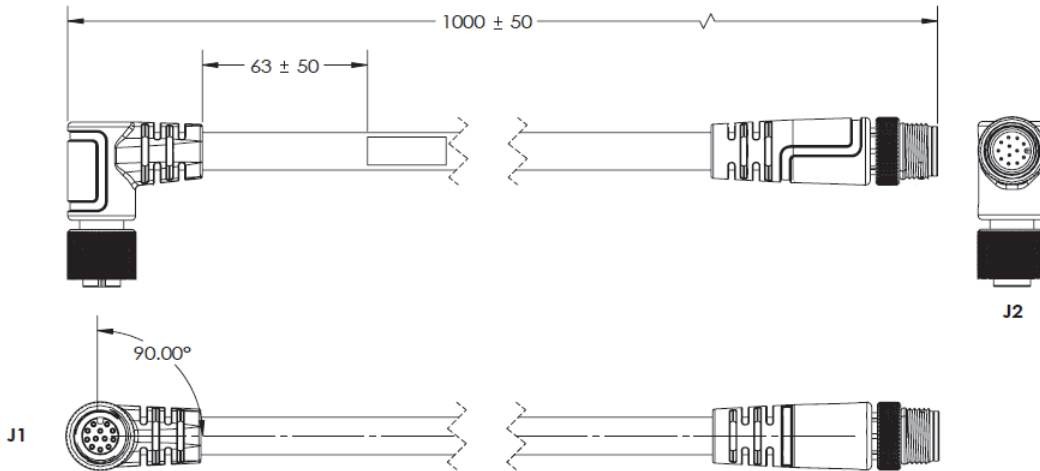



# A-4 Part Number Structure

## V320-F Part Number Structure

Use this legend when defining product part numbers. Please note that not all combinations of parameters are valid. For instance, fixed focus distance of 50 mm is not available with Narrow Lens. When ordering, use valid part numbers from the tables in the Ordering Information section only.

### V320-F[XXX][Y][ZZZ]-NN[P]

Key	Classification	Code	Meaning
XXX	Focus Distance (mm)	050	Fixed Focus at 50 mm
		064	Fixed Focus at 64 mm
		081	Fixed Focus at 81 mm
		102	Fixed Focus at 102 mm
		133	Fixed Focus at 133 mm
		190	Fixed Focus at 190 mm
		300	Fixed Focus at 300 mm
Y	Lens	W	Wide Field of View - 5.2 mm Focal Length Lens
		M	Medium Field of View – 7.7 mm Focal Length Lens
		N	Narrow Field of View – 16 mm Focal Length Lens
ZZZ	Sensor	03M	752 x 480 (0.3 MP) Pixel, Mono Sensor, Global Shutter
		12M	1280 x 960 (1.2 MP) Pixel, Mono Sensor, Global Shutter
		50C	2592 x 1944 (5 MP) Pixel, Color Sensor, Rolling Shutter
L	Light Type	N	No Outer Light
C	Light Color	N	No Outer Light
P	Software License	P	High Speed, Plus Mode
		X	High Speed, X-Mode

#### Example Part Number:

- V320-F050W03M-NNX: Fixed Focus at 50 mm, Wide Lens, 0.3 MP Monochrome, No Light, High Speed, X-Mode

### V320-F Valid Product Matrix

Model	Category	Focus Type	Sensor	Lens	Focus Distance (mm)	Light	License
V320-F	Monochrome	Fixed Focus	03M, 12M	W, M	50, 64, 81, 102, 133, 190, 300	None	P, X
	Color	Fixed Focus	50C	W, M	50, 64, 81, 102, 133, 190, 300	None	P, X
	Monochrome	Fixed Focus	03M, 12M	N	64, 81, 102, 133, 190, 300	None	P, X
	Color	Fixed Focus	50C	N	64, 81, 102, 133, 190, 300	None	P, X

## V320-F Ordering Information

### Categories:

#### 1. Fixed Focus Cameras

- a) V320 Monochrome and Color Fixed Focus Camera with Standard Lens
- b) V320 Monochrome and Color Fixed Focus Camera with Narrow Lens

#### 1a) V320 Mono and Color Camera with Standard Lens: Valid Combinations

##### V320-F[XXX][Y][ZZZ]-NN[P]

Key	Classification	Code	Meaning
XXX	Focus Distance (mm)	050	Fixed Focus at 50 mm
		064	Fixed Focus at 64 mm
		081	Fixed Focus at 81 mm
		102	Fixed Focus at 102 mm
		133	Fixed Focus at 133 mm
		190	Fixed Focus at 190 mm
		300	Fixed Focus at 300 mm
Y	Lens	W	Wide Field of View - 5.2 mm Focal Length Lens
		M	Medium Field of View – 7.7 mm Focal Length Lens
ZZZ	Sensor	03M	752 x 480 (0.3 MP) Pixel, Mono Sensor, Global Shutter
		12M	1280 x 960 (1.2 MP) Pixel, Mono Sensor, Global Shutter
		50C	2592 x 1944 (5 MP) Pixel, Color Sensor, Rolling Shutter
P	Software License	P	High Speed, Plus Mode
		X	High Speed, X-Mode

#### 1b) V320 Mono and Color Camera with Narrow Lens: Valid Combinations

**Note:** 50 mm Fixed Focus option is not available with Narrow Lens.

##### V320-F[XXX]N[ZZZ]-NN[P]

Key	Classification	Code	Meaning
XXX	Focus Distance (mm)	064	Fixed Focus at 64 mm
		081	Fixed Focus at 81 mm
		102	Fixed Focus at 102 mm
		133	Fixed Focus at 133 mm
		190	Fixed Focus at 190 mm
		300	Fixed Focus at 300 mm
		ZZZ	Sensor
12M	1280 x 960 (1.2 MP) Pixel, Mono Sensor, Global Shutter		
50C	2592 x 1944 (5 MP) Pixel, Color Sensor, Rolling Shutter		
P	Software License	P	High Speed, Plus Mode
		X	High Speed, X-Mode

### V330-F Part Number Structure

Use this legend when defining product part numbers. Please note that not all combinations of parameters are valid. For instance, fixed focus distance of 50 mm is not available with Narrow Lens. When ordering, use valid part numbers from the tables in the Ordering Information section only.

#### V330-F[XXX][Y][ZZZ]-NN[P]

Key	Classification	Code	Meaning
XXX	Focus Distance (mm)	050	Fixed Focus at 50 mm
		064	Fixed Focus at 64 mm
		081	Fixed Focus at 81 mm
		102	Fixed Focus at 102 mm
		133	Fixed Focus at 133 mm
		190	Fixed Focus at 190 mm
		300	Fixed Focus at 300 mm
Y	Lens	W	Wide Field of View - 5.2 mm Focal Length Lens
		M	Medium Field of View – 7.7 mm Focal Length Lens
		N	Narrow Field of View – 16 mm Focal Length Lens
ZZZ	Sensor	03M	752 x 480 (0.3 MP) Pixel, Mono Sensor, Global Shutter
		12M	1280 x 960 (1.2 MP) Pixel, Mono Sensor, Global Shutter
		50C	2592 x 1944 (5 MP) Pixel, Color Sensor, Rolling Shutter
L	Light Type	N	No Outer Light
C	Light Color	N	No Outer Light
P	Software License	P	High Speed, Plus Mode
		X	High Speed, X-Mode

**Example Part Number:**

- V330-F064N50C-NNX: Fixed Focus at 64 mm, Narrow Lens, 5 MP Color – No Light, High Speed, X-Mode

#### V330-F Valid Product Matrix

Model	Category	Focus Type	Sensor	Lens	Focus Distance (mm)	Light	License
V330-F	Monochrome	Fixed Focus	03M, 12M	W, M	50, 64, 81, 102, 133, 190, 300	None	P, X
	Color	Fixed Focus	50C	W, M	50, 64, 81, 102, 133, 190, 300	None	P, X
	Monochrome	Fixed Focus	03M, 12M	N	64, 81, 102, 133, 190, 300	None	P, X
	Color	Fixed Focus	50C	N	64, 81, 102, 133, 190, 300	None	P, X



## V330-F Ordering Information

### Categories:

#### 1. Fixed Focus Cameras

- a) V330-F Monochrome and Color Fixed Focus Camera with Standard Lens
- b) V330-F Monochrome and Color Fixed Focus Camera with Narrow Lens

#### 1a) V330-F Mono and Color Camera with Standard Lens: Valid Combinations

##### V330-F[XXX][Y][ZZZ]-NN[P]

Key	Classification	Code	Meaning
XXX	Focus Distance (mm)	050	Fixed Focus at 50 mm
		064	Fixed Focus at 64 mm
		081	Fixed Focus at 81 mm
		102	Fixed Focus at 102 mm
		133	Fixed Focus at 133 mm
		190	Fixed Focus at 190 mm
		300	Fixed Focus at 300 mm
Y	Lens	W	Wide Field of View - 5.2 mm Focal Length Lens
		M	Medium Field of View – 7.7 mm Focal Length Lens
ZZZ	Sensor	03M	752 x 480 (0.3 MP) Pixel, Mono Sensor, Global Shutter
		12M	1280 x 960 (1.2 MP) Pixel, Mono Sensor, Global Shutter
		50C	2592 x 1944 (5 MP) Pixel, Color Sensor, Rolling Shutter
P	Software License	P	High Speed, Plus Mode
		X	High Speed, X-Mode

#### 1b) V330-F Mono and Color Camera with Narrow Lens: Valid Combinations

**Note:** 50 mm Fixed Focus option not available with Narrow Lens.

##### V330-F[XXX]N[ZZZ]-NN[P]

Key	Classification	Code	Meaning
XXX	Focus Distance (mm)	064	Fixed Focus at 64 mm
		081	Fixed Focus at 81 mm
		102	Fixed Focus at 102 mm
		133	Fixed Focus at 133 mm
		190	Fixed Focus at 190 mm
		300	Fixed Focus at 300 mm
		ZZZ	Sensor
12M	1280 x 960 (1.2 MP) Pixel, Mono Sensor, Global Shutter		
50C	2592 x 1944 (5 MP) Pixel, Color Sensor, Rolling Shutter		
P	Software License	P	High Speed, Plus Mode
		X	High Speed, X-Mode

## V420-F Part Number Structure

Use this legend when defining product part numbers. Please note that not all combinations of parameters are valid. For instance, color cameras are only available with white lighting, and 400 mm fixed focus is only available with UHD lenses. When ordering, use valid part numbers from the tables in the Ordering Information section only.

### V420-F[XXX][Y][ZZZ]-[L][C][P]

Key	Classification	Code	Meaning
XXX	Focus Distance (mm)	000	Autofocus – Variable Distance
		050	Fixed Focus at 50 mm
		064	Fixed Focus at 64 mm
		081	Fixed Focus at 81 mm
		102	Fixed Focus at 102 mm
		133	Fixed Focus at 133 mm
		190	Fixed Focus at 190 mm
		300	Fixed Focus at 300 mm
		400	Fixed Focus at 400 mm
Y	Lens	W	Wide Field of View – 5.2 mm Focal Length Lens
		M	Medium Field of View – 7.7 mm Focal Length Lens
		N	Narrow Field of View – 16 mm Focal Length Lens
		L	Narrow 16 mm Lens – Autofocus to 1160 mm
ZZZ	Sensor	03M	752 x 480 (0.3 MP) Pixel, Mono Sensor, Global Shutter
		12M	1280 x 960 (1.2 MP) Pixel, Mono Sensor, Global Shutter
		50C	2592 x 1944 (5 MP) Pixel, Color Sensor, Rolling Shutter
L	Light Type	N	No Outer Light
		S	Standard Outer Light
C	Light Color	N	No Outer Light
		R	Red
		W	White
P	Software License	P	High Speed, Plus Mode
		X	High Speed, X-Mode

#### Example Part Numbers:

- V420-F081W03M-NNP: Fixed Focus at 81 mm, Wide Lens, 0.3 MP Monochrome Sensor, No Outer Light, High Speed, Plus Mode
- V420-F000W50C-SWP: Autofocus, Wide Lens, 5 MP Color, Standard Light, White, High Speed, Plus Mode

## V420-F Valid Product Matrix

Model	Category	Focus Type	Sensor	Lens	Focus Distance (mm)	Light	License
V420-F	Monochrome	Fixed Focus	03M, 12M	W, M	50, 64, 81, 102, 133, 190, 300	None, Red, White	P, X
			12M	N	400	None, Red, White	P, X
		Autofocus	03M	W, M	50 <-> 300 Autofocus	None, Red, White	P, X
			12M	W, M, N	50 <-> 300 (W, M) 40 <-> 150 (N) Autofocus	None, Red, White	P, X
	Color	Fixed Focus	50C	W, M	50, 64, 81, 102, 133, 190, 300	None, White	P, X
		Autofocus	50C	W, M	50 <-> 300 Autofocus	None, White	P, X
	Specialty	Long Range Autofocus	12M	L	75 <-> 1160 Autofocus	None, Red, White	P, X

## V420-F Ordering Information

### Categories:

#### 1. Fixed Focus Camera

- a.) V420-F Monochrome Fixed Focus Camera
- b.) V420-F Color Fixed Focus Camera
- c.) V420-F 1.2 MP Monochrome Fixed Focus Camera with Narrow Lens

#### 2. Autofocus Camera

- a.) V420-F 0.3 MP Monochrome Autofocus Camera (50 -300 mm)
- b.) V420-F 1.2 MP Monochrome Autofocus Camera (50 – 300 mm for Wide and Medium Lens, 40 – 150 mm for Narrow Lens)
- c.) V420-F Color Autofocus Camera (50 - 300 mm)
- d.) V420-F 1.2 MP Monochrome Long Range Autofocus Camera (75 - 1160 mm)

### 1a) V420-F Monochrome Fixed Focus Camera: Valid Combinations

V420-F[XXX][Y][ZZZ]-[L][C][P]

Key	Classification	Code	Meaning
XXX	Focus Distance (mm)	050	Fixed Focus at 50 mm
		064	Fixed Focus at 64 mm
		081	Fixed Focus at 81 mm
		102	Fixed Focus at 102 mm
		133	Fixed Focus at 133 mm
		190	Fixed Focus at 190 mm
		300	Fixed Focus at 300 mm
Y	Lens	W	Wide Field of View - 5.2 mm Focal Length Lens
		M	Medium Field of View – 7.7 mm Focal Length Lens
ZZZ	Sensor	03M	752 x 480 (0.3 MP) Pixel, Mono Sensor, Global Shutter
		12M	1280 x 960 (1.2 MP) Pixel, Mono Sensor, Global Shutter
L	Light Type	N	No Outer Light
		S	Standard Outer Light
C	Light Color	N	No Outer Light
		R	Red
		W	White
P	Software License	P	High Speed, Plus Mode
		X	High Speed, X-Mode

### 1b) V420-F 5.0 MP Color Fixed Focus Camera: Valid Combinations

Note: 5 MP Color cameras are available with No Outer Light or White Light options only.

V420-F[XXX][Y]50C-[L][C][P]

Key	Classification	Code	Meaning
XXX	Focus Distance (mm)	050	Fixed Focus at 50 mm
		064	Fixed Focus at 64 mm
		081	Fixed Focus at 81 mm
		102	Fixed Focus at 102 mm
		133	Fixed Focus at 133 mm
		190	Fixed Focus at 190 mm
		300	Fixed Focus at 300 mm
Y	Lens	W	Wide Field of View - 5.2 mm Focal Length Lens
		M	Medium Field of View – 7.7 mm Focal Length Lens
L	Light Type	N	No Outer Light
		S	Standard Outer Light
C	Light Color	N	No Outer Light
		W	White
P	Software License	P	High Speed, Plus Mode
		X	High Speed, X-Mode

**1c) V420-F 1.2 MP Monochrome Fixed Focus Camera with Narrow Lens: Valid Combinations**

**Note:** Fixed Focus Narrow lens option available for 1.2 MP Mono camera only.

**V420-F[XXX]N12M-[L][C][P]**

Key	Classification	Code	Meaning
XXX	Focus Distance (mm)	400	Fixed Focus at 400 mm
L	Light Type	N	No Outer Light
		S	Standard Outer Light
C	Light Color	N	No Outer Light
		R	Red
		W	White
P	Software License	P	High Speed, Plus Mode
		X	High Speed, X-Mode

**2a) V420-F 0.3 MP Monochrome Autofocus Camera (50 - 300 mm): Valid Combinations**

**V420-F000[Y]03M-[L][C][P]**

Key	Classification	Code	Meaning
Y	Lens	W	Wide Field of View - 5.2 mm Focal Length Lens
		M	Medium Field of View – 7.7 mm Focal Length Lens
L	Light Type	N	No Outer Light
		S	Standard Outer Light
C	Light Color	N	No Outer Light
		R	Red
		W	White
P	Software License	P	High Speed, Plus Mode
		X	High Speed, X-Mode



**2b) V420-F 1.2 MP Monochrome Autofocus Camera (50 – 300 mm for Wide and Medium, 40 – 150 mm for Narrow): Valid Combinations**

**V420-F000[Y]12M-[L][C][P]**

Key	Classification	Code	Meaning
Y	Lens	W	Wide Field of View - 5.2 mm Focal Length Lens
		M	Medium Field of View – 7.7 mm Focal Length Lens
		N	Narrow Field of View – 16 mm Focal Length Lens
L	Light Type	N	No Outer Light
		S	Standard Outer Light
C	Light Color	N	No Outer Light
		R	Red
		W	White
P	Software License	P	High Speed, Plus Mode
		X	High Speed, X-Mode

**2c) V420-F 5.0 MP Color Autofocus Camera (50 - 300 mm): Valid Combinations**

**Note:** Narrow Autofocus lens option not available for color camera.

**V420-F000[Y]50C-[L][C][P]**

Key	Classification	Code	Meaning
Y	Lens	W	Wide Field of View - 5.2 mm Focal Length Lens
		M	Medium Field of View – 7.7 mm Focal Length Lens
L	Light Type	N	No Outer Light
		S	Standard Outer Light
C	Light Color	N	No Outer Light
		W	White
P	Software License	P	High Speed, Plus Mode
		X	High Speed, X-Mode

## 2d) V420-F 1.2 MP Monochrome Long Range Autofocus Camera (75 - 1160 mm): Valid Combinations

**Note:** Autofocus Long Range lens option available for 1.2 MP Monochrome camera only.

### V420-F000L12M-[L][C][P]

Key	Classification	Code	Meaning
L	Light Type	N	No Outer Light
		S	Standard Outer Light
C	Light Color	N	No Outer Light
		R	Red
		W	White
P	Software License	P	High Speed, Plus Mode
		X	High Speed, X-Mode

## V430-F Part Number Structure

Use this legend when defining product part numbers. Please note that not all combinations of parameters are valid. For instance, color cameras are only available with white lighting, and 400 mm fixed focus is only available with UHD lenses. When ordering, use valid part numbers from the tables in the Ordering Information section only.

### V430-F[XXX][Y][ZZZ]-[L][C][P]

Key	Classification	Code	Meaning
XXX	Focus Distance (mm)	000	Autofocus – Variable Distance
		050	Fixed Focus at 50 mm
		064	Fixed Focus at 64 mm
		081	Fixed Focus at 81 mm
		102	Fixed Focus at 102 mm
		133	Fixed Focus at 133 mm
		190	Fixed Focus at 190 mm
		300	Fixed Focus at 300 mm
		400	Fixed Focus at 400 mm
		Y	Lens
M	Medium Field of View – 7.7 mm Focal Length Lens		
N	Narrow Field of View – 16 mm Focal Length Lens		
L	Narrow 16 mm Lens – Autofocus to 1160 mm		
ZZZ	Sensor	03M	752 x 480 (0.3 MP) Pixel, Mono Sensor, Global Shutter
		12M	1280 x 960 (1.2 MP) Pixel, Mono Sensor, Global Shutter
		50C	2592 x 1944 (5 MP) Pixel, Color Sensor, Rolling Shutter
L	Light Type	N	No Outer Light
		S	Standard Outer Light
		R	Ring Light
C	Light Color	N	No Outer Light
		R	Red
		W	White
P	Software License	P	High Speed, Plus Mode
		X	High Speed, X-Mode

#### Example Part Numbers:

- V430-F081W03M-NNP: Fixed Focus at 81 mm, Wide Lens, 0.3 MP Monochrome Sensor, No Outer Light, High Speed, Plus Mode
- V430-F000N12M-RRX: Autofocus, Narrow Lens, 1.2 MP Mono, Ring Light, Red, High Speed, X-Mode
- V430-F000W50C-SWP: Autofocus, Wide Lens, 5 MP Color, Standard Light, White, High Speed, Plus Mode



**V430-F Valid Product Matrix**

Model	Category	Focus Type	Sensor	Lens	Focus Distance (mm)	Light	License
V430-F	Monochrome	Fixed Focus	03M, 12M	W, M	50, 64, 81, 102, 133, 190, 300	None, Red, White	P, X
			12M	N	400	None, Red, White	P, X
		Autofocus	03M	W, M	50 <-> 300 Autofocus	None, Red, White	P, X
			12M	W, M, N	50 <-> 300 (W, M) 40 <-> 150 (N) Autofocus	None, Red, White	P, X
	Color	Fixed Focus	50C	W, M	50, 64, 81, 102, 133, 190, 300	None, White	P, X
		Autofocus	50C	W, M	50 <-> 300 Autofocus	None, White	P, X
	Specialty	Ring Light Autofocus	12M	M, N	50 <-> 300 (M) 40 <-> 150 (N) Autofocus	Red, White (Ring)	X
		Long Range Autofocus	12M	L	75 <-> 1160 Autofocus	None, Red, White	P, X



**V430-F Ordering Information**

**Categories:**

**1. Fixed Focus Camera**

- a.) V430-F Monochrome Fixed Focus Camera
- b.) V430-F Color Fixed Focus Camera
- c.) V430-F 1.2 MP Monochrome Fixed Focus Camera with Narrow Lens

**2. Autofocus Camera**

- a.) V430-F 0.3 MP Monochrome Autofocus Camera (50 - 300 mm)
- b.) V430-F 1.2 MP Monochrome Autofocus Camera (50 - 300 mm for Wide and Medium Lens, 40 - 150 mm for Narrow Lens)
- c.) V430-F Color Autofocus Camera (50 - 300 mm)
- d.) V430-F 1.2 MP Monochrome Autofocus Camera with Ring Light (50 – 300 mm for Medium Lens, 40 - 150 mm for Narrow Lens)
- e.) V430-F 1.2 MP Monochrome Long Range Autofocus Camera (75 - 1160 mm)

**1a) V430-F Monochrome Fixed Focus Camera: Valid Combinations**

**V430-F[XXX][Y][ZZZ]-[L][C][P]**

Key	Classification	Code	Meaning
<b>XXX</b>	Focus Distance (mm)	050	Fixed Focus at 50 mm
		064	Fixed Focus at 64 mm
		081	Fixed Focus at 81 mm
		102	Fixed Focus at 102 mm
		133	Fixed Focus at 133 mm
		190	Fixed Focus at 190 mm
		300	Fixed Focus at 300 mm
<b>Y</b>	Lens	W	Wide Field of View - 5.2 mm Focal Length Lens
		M	Medium Field of View – 7.7 mm Focal Length Lens
<b>ZZZ</b>	Sensor	03M	752 x 480 (0.3 MP) Pixel, Mono Sensor, Global Shutter
		12M	1280 x 960 (1.2 MP) Pixel, Mono Sensor, Global Shutter
<b>L</b>	Light Type	N	No Outer Light
		S	Standard Outer Light
<b>C</b>	Light Color	N	No Outer Light
		R	Red
		W	White
<b>P</b>	Software License	P	High Speed, Plus Mode
		X	High Speed, X-Mode

**1b) V430-F 5.0 MP Color Fixed Focus Camera: Valid Combinations**

**Note:** 5 MP Color cameras are available with No Outer Light or White Light options only.

**V430-F[XXX][Y]50C-[L][C][P]**

Key	Classification	Code	Meaning
XXX	Focus Distance (mm)	050	Fixed Focus at 50 mm
		064	Fixed Focus at 64 mm
		081	Fixed Focus at 81 mm
		102	Fixed Focus at 102 mm
		133	Fixed Focus at 133 mm
		190	Fixed Focus at 190 mm
		300	Fixed Focus at 300 mm
Y	Lens	W	Wide Field of View - 5.2 mm Focal Length Lens
		M	Medium Field of View – 7.7 mm Focal Length Lens
L	Light Type	N	No Outer Light
		S	Standard Outer Light
C	Light Color	N	No Outer Light
		W	White
P	Software License	P	High Speed, Plus Mode
		X	High Speed, X-Mode

**1c) V430-F 1.2 MP Monochrome Fixed Focus Camera with Narrow Lens: Valid Combinations**

**Note:** Fixed Focus Narrow lens option available for 1.2 MP Mono camera only.

**V430-F[XXX]N12M-[L][C][P]**

Key	Classification	Code	Meaning
XXX	Focus Distance (mm)	400	Fixed Focus at 400 mm
L	Light Type	N	No Outer Light
		S	Standard Outer Light
C	Light Color	N	No Outer Light
		R	Red
		W	White
P	Software License	P	High Speed, Plus Mode
		X	High Speed, X-Mode

**2a) V430-F 0.3 MP Monochrome Autofocus Camera (50 - 300 mm): Valid Combinations**

**V430-F000[Y]03M-[L][C][P]**

Key	Classification	Code	Meaning
Y	Lens	W	Wide Field of View - 5.2 mm Focal Length Lens
		M	Medium Field of View – 7.7 mm Focal Length Lens
L	Light Type	N	No Outer Light
		S	Standard Outer Light
C	Light Color	N	No Outer Light
		R	Red
		W	White
P	Software License	P	High Speed, Plus Mode
		X	High Speed, X-Mode

**2b) V430-F 1.2 MP Monochrome Autofocus Camera (50 - 300 mm for Wide and Medium, 40 – 150 mm for Narrow): Valid Combinations**

**V430-F000[Y]12M-[L][C][P]**

Key	Classification	Code	Meaning
Y	Lens	W	Wide Field of View - 5.2 mm Focal Length Lens
		M	Medium Field of View – 7.7 mm Focal Length Lens
		N	Narrow Field of View – 16 mm Focal Length Lens
L	Light Type	N	No Outer Light
		S	Standard Outer Light
C	Light Color	N	No Outer Light
		R	Red
		W	White
P	Software License	P	High Speed, Plus Mode
		X	High Speed, X-Mode

**2c) V430-F 5.0 MP Color Autofocus Camera (50 - 300 mm): Valid Combinations**

**Note:** Narrow Autofocus lens option not available for color camera.

**V430-F000[Y]50C-[L][C][P]**

Key	Classification	Code	Meaning
Y	Lens	W	Wide Field of View - 5.2 mm Focal Length Lens
		M	Medium Field of View – 7.7 mm Focal Length Lens
L	Light Type	N	No Outer Light
		S	Standard Outer Light
C	Light Color	N	No Outer Light
		W	White
P	Software License	P	High Speed, Plus Mode
		X	High Speed, X-Mode

**2d) V430-F 1.2 MP Monochrome Autofocus Camera with Ring Light (50 - 300 mm for Medium, 40 – 150 mm for Narrow): Valid Combinations**

**Note:** Ring Light version is available for Autofocus, Medium, and Narrow lens, 1.2 MP Monochrome camera only.

**V430-F000[Y]12M-R[C]X**

Key	Classification	Code	Meaning
Y	Lens	M	Medium Field of View – 7.7 mm Focal Length Lens
		N	Narrow Field of View – 16 mm Focal Length Lens
C	Light Color	R	Red
		W	White

**2e) V430-F 1.2 MP Monochrome Long Range Autofocus Camera (75 - 1160 mm): Valid Combinations**

**Note:** Autofocus Long Range lens option available for 1.2 MP Monochrome camera only.

**V430-F000L12M-[L][C][P]**

Key	Classification	Code	Meaning
L	Light Type	N	No Outer Light
		S	Standard Outer Light
C	Light Color	N	No Outer Light
		R	Red
		W	White
P	Software License	P	High Speed, Plus Mode
		X	High Speed, X-Mode

A



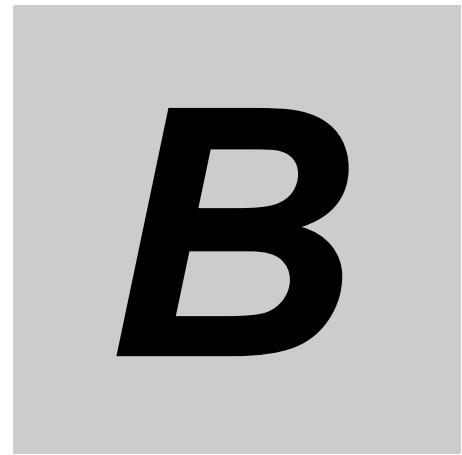

# Electrical Specifications

B

This section contains pin assignments for MicroHAWK V320-F, V330-F, V420-F, and V430-F readers, as well as grounding and isolation information specific to the V430-F.

---

<b>B-1</b>	<b>MicroHAWK V320-F</b> .....	<b>B-2</b>
<b>B-2</b>	<b>MicroHAWK V330-F</b> .....	<b>B-3</b>
<b>B-3</b>	<b>MicroHAWK V420-F</b> .....	<b>B-4</b>
<b>B-4</b>	<b>MicroHAWK V430-F</b> .....	<b>B-5</b>

# B-1 MicroHAWK V320-F

---

## RJ50 Socket, 10 Pins

---

**J1: Connector Type: RJ-50 Female, 10 Pins**

Pin Number	Signal Name	Description
1	D-	USB Differential Signal, Data -
2	D+	USB Differential Signal, Data +
3	USB VBUS	USB Host Power Source
4	GND	Ground
5	RS-232 RX	RS-232 Receive (To ID-22)
6	RS-232 TX	RS-232 Transmit (From ID-22)
7	+5V	External Power Source
8	GND	Ground
9	Output1	Output Strobe
10	Trigger	Input Trigger

## B-2 MicroHAWK V330-F

### RJ45 Connector, 8 Pins

PINS on Switch	10/100 DC on Spares (mode B)	10/100 Mixed DC & Data (mode A)
Pin 1	Rx +	Rx + DC +
Pin 2	Rx -	Rx - DC +
Pin 3	Tx +	Tx + DC -
Pin 4	DC +	unused
Pin 5	DC +	unused
Pin 6	Tx -	Tx - DC -
Pin 7	DC -	unused
Pin 8	DC -	unused

B

## B-3 MicroHAWK V420-F

### High-Density 15-Pin D-Sub Socket

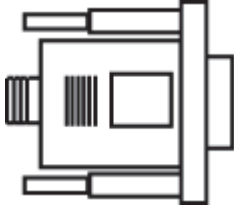

**Note:** An accessory cable is required between the V420-F's 15-pin corner-exit cable and the host's USB port.

<i>Pin</i>	<i>Function</i>
1	+5VDC
2	TX232
3	RX232
4	GND
5	D+
6	N/C
7	Output 1+
8	Default+
9	Trigger+
10	D-
11	Output 3+
12	New Master+
13	N/C
14	Output 2+
15	Vbus



# B-4 MicroHAWK V430-F

## M12 Connectors

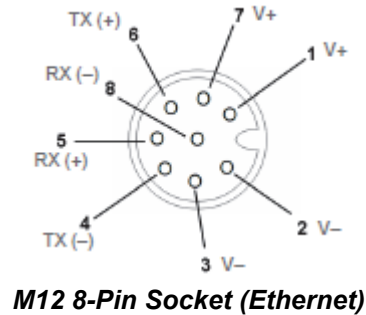
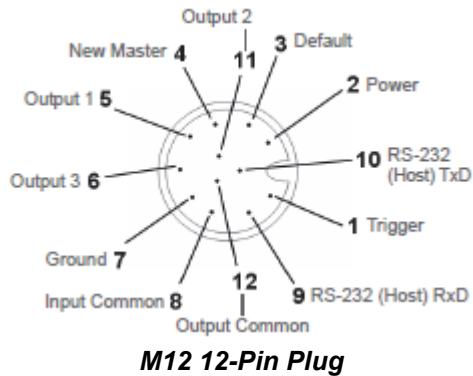

B

## Grounding and Isolation

**Important:** Mounting a reader to grounded conductive material may cause communication problems or unreliable operation. If you need to mount the reader to a bracket or plate, be sure that a proper ground connection is available. If a proper ground is not available, electrical isolation of the reader should be performed. Using Omron Microscan's Isolation Mounting Kit, P/N 98-9000064-01, will ensure that no ground loop or other external electrical noise can occur through the reader.

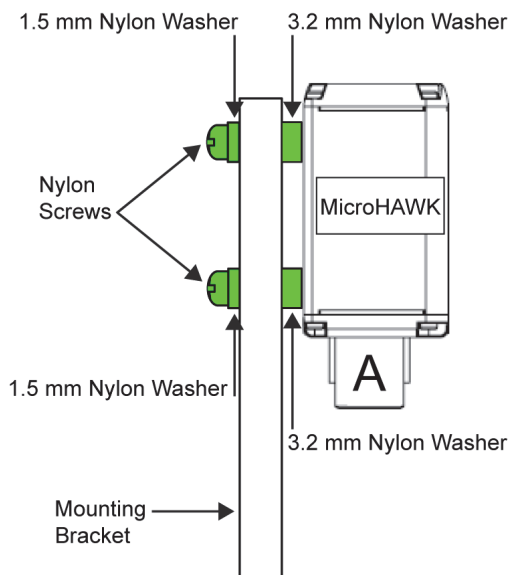



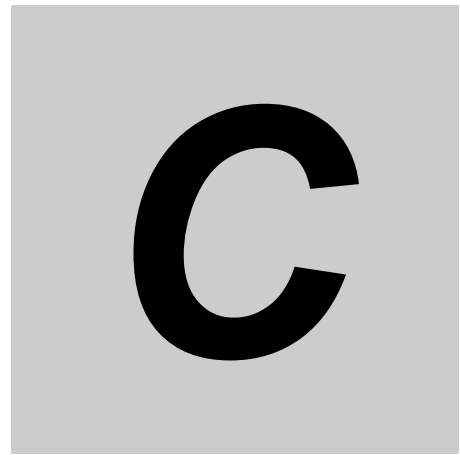

# Serial Commands



This section contains information about serial commands for MicroHAWK readers.

---

<b>C-1</b>	<b>Serial Commands</b> .....	<b>C-2</b>
------------	------------------------------	------------

# C-1 Serial Commands

---

## Serial Command Format

---

Omron Microscan readers are controlled by two types of serial commands: configuration commands and utility commands.

### ● Rules that apply to both configuration and utility commands

- Less than '<' and greater than '>' angle bracket characters enclose the commands.
- Commands and data are case sensitive. Characters must be entered as upper or lower case, as specified.

## Serial Utility Commands

---

Serial Utility Commands are sent during operations and are not followed by <A> or <Z>.

## Serial Configuration Commands (K Commands)

---

Omron Microscan's serial configuration commands begin with a single "K" character followed by a 3-digit numeric character, comma-separated command fields, and an initializing command, as follows:

*<Knumeric character,data,data,...etc.><initializing command>*

An initializing command <Z> or <A> may follow the command.

- <Z> initializes the memory and saves for power-on.
- <A> initializes the memory but does not save for power-on.

For example, to enable **UPC** and save the change for power-on, send <K473,1><Z>.

To change **Baud Rate** and reset without saving changes for power-on, send <K100,3><A>.

### ● Serial Configuration Command Conventions

- All command fields (except the last) must be followed by a comma (without a space).
- NULL cannot be used. The characters <, >, and , can be used, but only if entered as hex values.
- All fields preceding a modified field must be included.
- If there is no change in preceding fields, then commas alone can be entered in these fields. For example, if only the last field in the following command is changing, <K100,4,1,0,0> can be entered as <K100,,,,0>.
- All fields *following* a modified field can be omitted. For example, to change Baud Rate only, send <K100,3>.

## Concatenating Configuration Commands

---

Commands can be concatenated (added together) in a single string. For example, <K145,1><K220,1><A> enables **LRC**, sets **End of Read Cycle** mode to **New Trigger**, and resets the data buffers without saving the changes for power-on.

## Serial Command Status Request

---

To ensure that any command was received and accepted, send the **Show Reader Status** command: `<?>`.

The status of a specific serial command can be requested by entering the command followed by a question mark. For example, send `<K142?>` to request the status of **Postamble**.

## Entering Control Characters in Serial Commands

---

To enter control characters within a serial command, hold down the **Ctrl** key while typing the desired character.

**Example:** To enter a carriage return and line feed (**^M^J**), enter `<K141,1,CNTL-m CNTL-j>`





# Communications

This section explains how to set up communications with a host.

---

<b>D-1 Introduction</b> . . . . .	<b>D-2</b>
<b>D-2 Communications Serial Commands</b> . . . . .	<b>D-3</b>
<b>D-3 Custom Ethernet Link</b> . . . . .	<b>D-4</b>
<b>D-4 Host Port Connections</b> . . . . .	<b>D-11</b>
<b>D-5 Host Port Protocol</b> . . . . .	<b>D-12</b>
<b>D-6 ACK/NAK Options</b> . . . . .	<b>D-13</b>
<b>D-7 Polling Mode Options</b> . . . . .	<b>D-14</b>
<b>D-8 Ethernet</b> . . . . .	<b>D-15</b>
<b>D-9 Response Timeout</b> . . . . .	<b>D-16</b>
<b>D-10 LRC (Longitudinal Redundancy Check) Status</b> . . . . .	<b>D-17</b>
<b>D-11 Protocol Configuration Examples</b> . . . . .	<b>D-18</b>
<b>D-12 Preamble</b> . . . . .	<b>D-19</b>
<b>D-13 Postamble</b> . . . . .	<b>D-20</b>
<b>D-14 USB HID/Keyboard</b> . . . . .	<b>D-21</b>
<b>D-15 EtherNet/IP Byte Swapping Enabled</b> . . . . .	<b>D-23</b>
<b>D-16 PROFINET</b> . . . . .	<b>D-24</b>
<b>D-17 Entering ASCII Characters as Hex Values</b> . . . . .	<b>D-25</b>
<b>D-18 USB Mass Storage Driver</b> . . . . .	<b>D-26</b>

# D-1 Introduction

---

With WebLink, configuration changes can be made in the menus and then sent and saved to the reader. The user can also send serial commands to the reader via Terminal.

The following describes the basic flow of the serial (RS-232C) communications.

- Match RS-232C communication parameters (baud rate, parity, data bits, and stop bits) between the reader and the host.
- Send the read command “< >” from the host to reader.
- Send the “read result” from the reader to the host.

The serial (RS-232C) communications use serial commands stated in this manual.

For example, “Read” commands are described in Chapter 5 **Read Cycle**.

The following describes the basic flow of the serial (TCP) communications.

- The reader opens a port (default: 2001) as TCP server at startup.
- The higher connects to the reader as a TCP client.
- The host sends the “read command” “< >” to the reader .
- The reader sends the “read results” to the host.

The serial (TCP) communications use serial commands stated in this manual.

For example, “Read” commands are described in Chapter 5 **Read Cycle**.

The following describes the output format of serial (RS-232C, TCP) communications.

<Header> Read strings <Footer>

In default, the header is “None” and the footer is “CR+LF”. The header and footer can be changed with WebLink. (Gear icon - **Advanced - Communications - Preamble/Postamble**)

For example, When reading a code of 12345, the default output data is below.

Output format of serial communications	Output data						
ASCII character notation:	1	2	3	4	5	CR	LF
Hex notation:	31	32	33	34	35	0D	0A

Addition to read strings, coordinate information of a read code and the print quality evaluation information can be added.



## D-2 Communications Serial Commands

Host Port Connections	<K100,baud rate,parity,stop bits,data bits>
Ethernet	<K126,status,IP address,subnet,gateway,IP address mode>
Ethernet TCP Ports	<K127,TCP Port 1,TCP Port 2>
Search and Configure Mode	<K128,status,timed window>
EtherNet/IP	<K129,status>
Host Protocol	<K140,protocol,address>
Preamble	<K141,status,preamble characters>
Postamble	<K142,status,postamble characters>
Response Timeout	<K143,response timeout>
LRC Status	<K145,status>
ACK/NAK Options	<K147,RES,REQ,STX,ETX,ACK,NAK>
Polling Mode Options	<K148,RES,REQ,STX,ETX,ACK,NAK>
USB HID/Keyboard	<K149,Omron Microscan Report Enabled,Keyboard Report Enabled,Keyboard Language,USB VCOM Status,UART Status>
EtherNet/IP Byte Swapping Enabled	<K163,status>
PROFINET	<K164,status>
Custom Ethernet Link	<K166,status,transport layer,type,capabilities,IP address,multicast address,port,check connection,timeout (milliseconds),TTL>
USB Mass Storage Driver	<K900,status>

## D-3 Custom Ethernet Link

By default, the MicroHAWK reader operates as a server, and communicates with the host over TCP/IP for both commands and data.

**Custom Ethernet Link** functionality gives you the ability to create an Ethernet interface that is bound to the command processor per your own requirements. You can set the **Transport Layer** to **UDP** or **TCP**, set the message **Type** to **Server** or **Client**, and set **Capabilities** to **Send Only**, **Receive Only**, or **Send/Receive**.

Custom Ethernet Link	
☆ Custom Ethernet Link	Disabled
☆ Transport Layer	TCP
☆ Type	Server
☆ Capabilities	Send/Receive
☆ IP Address	192.168.1.65
☆ Multicast	232.169.247.185
☆ Port	5000
☆ Check Connection	Disabled
☆ Timeout	10000 ms
☆ TTL	128

Custom Ethernet Link is intended for advanced users. This feature permits the establishment of a connection to the reader on any port, using the protocols UDP/IP, TCP, and Multicast on a specified port. A bi-directional communication configuration is available to send commands to the reader, obtain barcode output data, or form a single direction of communication, i.e. sending commands to the reader only, or receiving barcode data from reader only, without having both directions open.

In addition to the ability to move ports, you can also force the connection created by the Custom Ethernet Link to act as a client. Instead of "reaching out" to the reader, it is possible to configure the reader to "go out and connect to" a specified server. This increases flexibility when integrating readers into customer applications. Without this feature, users are limited to static communication into and out of the reader – UDP=80, TCP1=2001, TCP2=2003.

The following section will cover the implementation of how the Custom Ethernet Object is implemented in an Ethernet-based reader. This additional Ethernet-based transport layer allows you to:

- Send "and/or" commands to the device from a specified endpoint;
- Send barcode data to a receiving endpoint i.e. a client or server;
- Handle more than one connecting endpoint connection.

With Custom Ethernet Link functionality, users can configure:

- Transport Layer;
- TCP, UDP, or Multicast;
- Message Type;
- Server or Client;
- The type of data sent and/or received from the device;
- The endpoint to send and receive data, send only barcode data, or receive only commands.

Custom Ethernet Link functionality is bound to the reader's command processor as shown in the figure below. This enables an outside endpoint to still send commands to the device as well as receive data commands and barcode to the receiver.

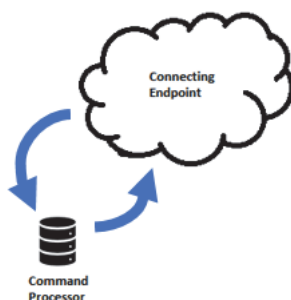

### D-3-1 Server Implementation

In cases where the endpoint is configured as a server, the reader is only able to handle 10 simultaneous connections for any transport layer. For TCP, the reader will refuse the connection. UDP and Multicast will simply ignore the connection request due to the connectionless nature of the transport layer.

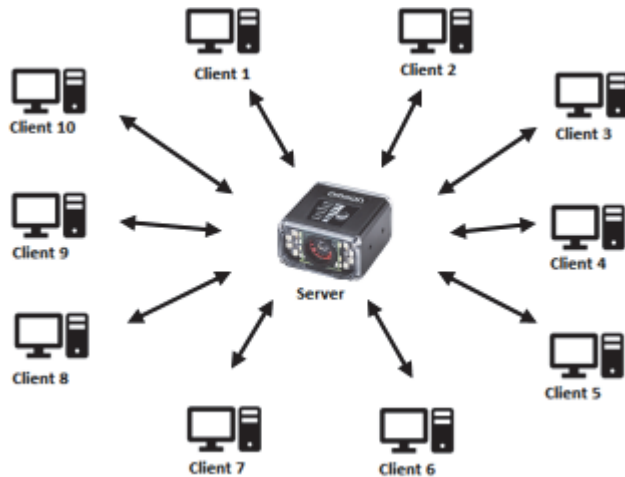

D

### D-3-2 Client Implementation

In cases where the endpoint is configured as a client, the reader is only able to handle one connection to a server. This means the following restrictions apply:

**TCP:** The reader can only connect to one server when configured as a client.

**UDP and Multicast:** The reader can only send data out on to one UDP port.



UDP is limited to UDP/IP in order to avoid broadcasting data on the network.

### D-3-3 Configuration

This section explains how to configure the Custom Ethernet Object in the reader. The **Custom Ethernet Link K Command <K166>** allows you to configure the Custom Ethernet Object in the reader.

**Important:** For information about Omron Microscan's proprietary **K Command** syntax, see [Appendix C](#) through [Appendix N](#).

The following section explains the command parameters that configure the Custom Ethernet Object. Note that each parameter described below corresponds with each parameter shown in the **Custom Ethernet Link** section of WebLink's **Communications** menu.

**K Command Format:** *<K166,status,transport layer,type,capabilities,IP address,multicast address,port,check connection,timeout (milliseconds),TTL>*

## Status

---

<K166,status,transport layer,type,capabilities,IP address,multicast address,port,check connection, timeout (milliseconds),TTL>

Status of the Custom Ethernet Object on the device.

**0 = Disabled Default** – The Custom Ethernet Object is not started.

**1 = Enabled** – The Custom Ethernet Object has started with the parameters configured.

## Transport Layer

---

<K166,status,transport layer,type,capabilities,IP address,multicast address,port,check connection, timeout (milliseconds),TTL>

The transport layer used by the Custom Ethernet Object to send/receive data. This transport layer obeys the **OSI Model layer 4**. The multicast implementation uses **UDP User Datagram Protocol** as the transport layer.

**0 = TCP Default**

**1 = UDP**

**2 = Multicast**

## Type

---

<K166,status,transport layer,type,capabilities,IP address,multicast address,port,check connection, timeout (milliseconds),TTL>

This is the how the feature runs on the device and follows the server client model.

**0 = Server Default** – In server mode the device will be listening on the configured port number. The server can handle up to 10 different connections at one time independent of the transport layer selection. Once the limit has been reached the server will reject other connections.

For Multicast server configuration the user can either use a specified Multicast address or leave the Multicast address to the configured Multicast APIPA Address. This Multicast address is safe to use according to RFC 4607 stating that Multicast ranges from 232.0.0.0 – 232.255.255.255 are okay to use for source specific applications. By default, the unit creates a unique Multicast address in the range of 232.169.xxx.xxx so it does not conflict with other multicast addresses.

**1 = Client** – In client mode the device will send data to the specified server. The user must configure the IP Address or Multicast Address of the server and the port number that the specified server is listening on. Improper configuration will either yield an error on startup or result in no data being transmitted from the device to the outside world.

## Capabilities

---

<K166,status,transport layer,type,capabilities,IP address,multicast address,port,check connection, timeout (milliseconds),TTL>

Capabilities is how the user configures the Custom Ethernet Object's read/write settings.

**1 = Receive** – The device will only receive data from the connecting endpoint. The device will not send data out to any connecting endpoints.

**2 = Send** – The device will only send data to the connecting endpoint. Any data received is immediately disposed of and not processed.

**3 = Send/Receive Default** – The device will be able to send and receive data to the connecting endpoint.

## IP Address

<K166,status,transport layer,type,capabilities,IP address,multicast address,port,check connection,timeout (milliseconds),TTL>

If the unit is configured as a client, the **IP Address** is determined by the **Transport Layer**.

**TCP** – This is the server's IP Address.

**UDP** – If the server uses UDP/IP, this is the IP Address of the server. Otherwise, it is ignored and the device will send data on the specified port.

**Multicast** – This parameter is the device's IP Address used to send out the Multicast message. You do not need to configure this parameter.

**Default = Unit's IP Address**

## Multicast Address

<K166,status,transport layer,type,capabilities,IP address,multicast address,port,check connection,timeout (milliseconds),TTL>

In **Server Mode**, this is the multicast address that clients can connect to in order to send/receive data. The port number is the port that the connecting endpoints will use.

In **Client Mode**, this is the multicast address of the server that the device is sending data to.

The port number is the port the multicast server is listening on.

**Default = 232.169.xxx.xxx Multicast APIPA Address**

## Port

<K166,status,transport layer,type,capabilities,IP address,multicast address,port,check connection,timeout (milliseconds),TTL>

In **Server Mode**, this is the port number that the connecting endpoints will use to connect to the device.

In **Client Mode**, this is the port number that the server is listening on.

**5000 (Default)**

## Check Connection

<K166,status,transport layer,type,capabilities,IP address,multicast address,port,check connection,timeout (milliseconds),TTL>

This feature is only applicable for **Transport Layer UDP** in **Client Mode**. The device will transmit **0** length UDP packets to the specified port that the server is listening on. If the device receives an **ICMP Port Destination Not Found**, then it will continue to send **0** length packets in an exponential back-off delay until the device no longer receives ICMP packets. This feature is disabled by default.

**0 = Disabled Default**

**1 = Enabled**

## Timeout (Milliseconds)

<K166,status,transport layer,type,capabilities,IP address,multicast address,port,check connection,timeout (milliseconds),TTL>

For TCP, this is the timeout before the socket is forcibly closed. For UDP and Multicast, this parameter has no effect.

**Default = 10,000**

## TTL

<K166,status,transport layer,type,capabilities,IP address,multicast address,port,check connection,timeout (milliseconds),TTL>

For Multicast, this is the Time-To-Live counter, or how many hops before the message is discarded by the network. By default, the counter is set to 128 hops, which is more than enough for a typical packet to reach its destination host. It can, however, be configured to last longer or shorter per network requirements.

**Default = 128**

## D-3-4 Configuration Examples

The following examples demonstrate how to configure the Custom Ethernet Object using the **Custom Ethernet Link K Command <K166>** described in the **Configuration** section earlier in this section.

### TCP

#### ● Server Mode

##### *Send/Receive Capabilities*

<K166,1,0,0,3>

##### Interpretation of K Command Settings:

- **Custom Ethernet Link Enabled Default, Transport Layer = TCP Default;**
- **Type = Server Default;**
- **Capabilities = Send/Receive Default**

##### *Send-Only Capabilities*

<K166,1,0,0,2>

##### Interpretation of K Command Settings:

- **Custom Ethernet Link Enabled Default, Transport Layer = TCP Default;**
- **Type = Server Default;**
- **Capabilities = Send**

#### ● Client Mode

The following client modes will connect to a **TCP Server** with **IP Address 192.168.188.5** listening on **port 5050**.



IP: 192.168.188.2  
Port: N/A



IP: 192.168.188.5  
Port: 5050

##### *Send/Receive Capabilities*

<K166,1,0,1,3,192.168.188.5,5050>

**Interpretation of K Command Settings:**

- **Custom Ethernet Link Enabled Default, Transport Layer = TCP Default;**
- **Type = Client;**
- **Capabilities = Send/Receive Default;**
- **IP Address = 192.168.188.5;**
- **Port = 5050**

**Send-Only Capabilities**

<K166,1,0,1,2,192.168.188.5, 5050>

**Interpretation of K Command Settings:**

- **Custom Ethernet Link Enabled Default, Transport Layer = TCP Default;**
- **Type = Client;**
- **Capabilities = Send;**
- **IP Address = 192.168.188.5, Port = 5050**

## UDP

### ● Server Mode

**Send/Receive Capabilities**

<K166,1,1,0,3>

**Interpretation of K Command Settings:**

- **Custom Ethernet Link Enabled Default, Transport Layer = UDP;**
- **Type = Server Default;**
- **Capabilities = Send/Receive Default**

**Send-Only Capabilities**

<K166,1,1,0,2>

**Interpretation of K Command Settings:**

- **Custom Ethernet Link Enabled Default, Transport Layer = UDP;**
- **Type = Server Default;**
- **Capabilities = Send**

### ● Client Mode

The following client modes will connect to a **UDP Server with IP Address 192.168.188.5** listening on **port 5050**.



IP: 192.168.188.2  
Port: 5050



IP: 192.168.188.5  
Port: 5050

**Send/Receive Capabilities**

<K166,1,1,1,3,192.168.188.5, 5050>

**Interpretation of K Command Settings:**

- **Custom Ethernet Link Enabled Default, Transport Layer = UDP;**
- **Type = Client;**
- **Capabilities = Send/Receive Default;**
- **IP Address = 192.168.188.5;**
- **Port = 5050**

**Send-Only Capabilities**

<K166,1,1,1,2,192.168.188.5, 5050>

**Interpretation of K Command Settings:**

- **Custom Ethernet Link Enabled Default, Transport Layer = UDP;**
- **Type = Client;**
- **Capabilities = Send;**
- **IP Address = 192.168.188.5;**
- **Port = 5050**

## Multicast

### ● Server Mode

The following uses the default **Multicast IP Address** generated in the device.

**Send/Receive Capabilities**

<K166,1,2,0,3>

**Interpretation of K Command Settings:**

- **Custom Ethernet Link Enabled Default, Transport Layer = Multicast;**
- **Type = Server Default;**
- **Capabilities = Send/Receive Default**

**Send-Only Capabilities**

<K166,1,2,0,2>

**Interpretation of K Command Settings:**

- **Custom Ethernet Link Enabled Default, Transport Layer = Multicast;**
- **Type = Server Default;**
- **Capabilities = Send**

### ● Client Mode

The following client modes will connect to a **Multicast** server with **IP Address 224.0.1.90** listening on **port 5050**.



IP: N/A  
Port: 5050



IP: 224.0.1.90  
Port: 5050

**Send/Receive Capabilities**

<K166,1,2,1,3, ,224.0.1.90,5050>

**Interpretation of K Command Settings:**

- **Custom Ethernet Link Enabled Default, Transport Layer = Multicast;**
- **Type = Client;**
- **Capabilities = Send/Receive Default;**
- **IP Address = 224.0.1.90;**
- **Port = 5050**

**Send-Only Capabilities**

<K166,1,2,1,2, ,224.0.1.90, ,5050>

**Interpretation of K Command Settings:**

- **Custom Ethernet Link Enabled Default, Transport Layer = Multicast;**
- **Type = Client;**
- **Capabilities = Send;**
- **IP Address = 224.0.1.90;**
- **Port = 5050**



## D-4 Host Port Connections

The host port can be configured with RS-232 connections.

The following settings define the basic transmission speeds and digital standards that ensure common formatting.

### D-4-1 Baud Rate, Host Port

*Usage:* Can be used to transfer data faster or to match host port settings.

*Definition:* The rate at which the reader and host transfer data back and forth.

*Serial Cmd:* <**K100**,*baud rate*,*parity*,*stop bits*,*data bits*>

*Default:* **115.2K**

*Options:*

0 = 600	1 = 1200	2 = 2400
3 = 4800	4 = 9600	5 = 19.2K
6 = 38.4K	7 = 57.6K	<b>8 = 115.2K</b>
9 = 230.4K		

D

### D-4-2 Parity, Host Port

*Usage:* Only changed if necessary to match host setting.

*Definition:* An error detection routine in which one data bit per character is set to 1 or 0 so that the total number of bits in the data field is either even or odd.

*Serial Cmd:* <**K100**,*baud rate*,*parity*,*stop bits*,*data bits*>

*Default:* **None**

*Options:* **0 = None**                      1 = Even                      2 = Odd

### D-4-3 Stop Bits, Host Port

*Usage:* Only changed if necessary to match host setting.

*Definition:* One or two bits added to the end of each character to indicate the end of the character.

*Serial Cmd:* <**K100**,*baud rate*,*parity*,**stop bits**,*data bits*>

*Default:* **One**

*Options:* **0 = One**                      1 = Two

### D-4-4 Data Bits, Host Port

*Usage:* Only changed if necessary to match host setting.

*Serial Cmd:* <**K100**,*baud rate*,*parity*,*stop bits*,**data bits**>

*Default:* **Eight**

*Options:* 0 = Seven                      **1 = Eight**

## D-5 Host Port Protocol

- Usage:* In general, the point-to-point protocols will work well in most applications. They require no address and must use RS-232 communications standards.
- Definition:* Protocols define the sequence and format in which information is transferred between the reader and the host.
- Serial Cmd:* <K140,protocol,address>
- Default:* **Point-to-Point**
- Options:* **0 = Point-to-Point**  
4 = ACK/NAK  
5 = Polling Mode

- **Note:** In all protocol modes, the preamble <K141> and postamble <K142> character strings can be used to frame the decode data, and both are included in calculating the **LRC** (Longitudinal Redundancy Check).

### D-5-1 Point-to-Point (Standard)

- Usage:* Used only with RS-232.
- Definition:* Standard **Point-to-Point** requires no address and sends the data to the host whenever it is available, without a request or handshake from the host.
- Serial Cmd:* <K140,0>

### D-5-2 ACK/NAK

- Definition:* See the **ACK/NAK Options** command <K147>.
- Serial Cmd:* <K140,4>

### D-5-3 Polling Mode

- Definition:* See the **Polling Mode Options** command <K148>.
- Serial Cmd:* <K140,5>

### Poll Address

- Serial Cmd:* <K140,protocol,address>
- Default:* **1**
- Options:* 1 to 50  
1 = Poll address 0x1C, Select address 0x1D  
2 = Poll address 0x1E, Select address 0x1F  
...  
50 = Poll address 0x7E, Select address 0x7F

## D-6 ACK/NAK Options

**Definition:** These parameters take effect for **ACK/NAK <K140,4>** on the main RS-232 port and are completely independent of the **Polling Mode Options <K148>**. The reader always follows the protocol in both directions (to and from the host). There is no option to disable it from either direction.

**Serial Cmd:** <K147,RES,REQ,STX,ETX,ACK,NAK>

### D-6-1 RES-NAK Defaults

<i>RES: (Reset)</i>	00 (disabled)
<i>REQ: (Request)</i>	00 (disabled)
<i>STX: (Start of Text)</i>	00 (disabled)
<i>ETX: (End of Text)</i>	00 (disabled)
<i>ACK: (Acknowledge)</i>	06
<i>NAK: (Negative Acknowledge)</i>	15

The following are general outlines of the **ACK/NAK** protocol. Items that are framed by brackets ( [ ] ) can either be disabled or enabled. LRC does not include STX, but it does include preamble, postamble, and ETX.

#### Symbol Data Output

**TX to host:** [STX] [preamble] SYMBOL DATA [postamble] [ETX] [LRC]

**Response from host:** ACK/NAK. Sent when LRC, ETX, postamble, or timeout (waiting for more data) are detected (if REQ is disabled) depending on what is enabled.

#### Commands from Host to Reader

**TX to Reader:** [STX] <command> [ETX] [LRC]

**Response from Reader:** ACK/NAK. Sent when LRC, ETX, or command-ending angle bracket '>' are received, depending on what is enabled.

#### Command Response from Reader to Host

**TX to host:** [STX] [preamble] COMMAND RESPONSE DATA [postamble] [ETX] [LRC]

**Response from host:** ACK/NAK. Sent when LRC, ETX, postamble, command-ending angle bracket '>', or timeout (waiting for more data) are detected, depending on what is enabled.

As with **Polling Mode <K140,5>**, the reader can optionally perform the REQ and RES event sequences in ACK/NAK mode. If the sender does not receive an ACK or NAK, it will send REQ to request such a response (if enabled). When the sender receives an ACK, too many NAKs, or times out (if already enabled), it will send a RES (if enabled) to terminate the transaction.

- **Note:** See **ACK/NAK Data Flow Examples** for sample ACK/NAK communication scenarios.

## D-7 Polling Mode Options

*Definition:* These parameters only take effect for **Polling Mode <K140,5>** on the main RS-232 port and are completely independent of the **ACK/NAK Options <K147>**.

The values of protocol characters can be changed, but the protocol events cannot be disabled. The polling mode address is configured in the **<K140>** command (see **Poll Address**).

If RS-232 is enabled, **<K102,0>**, **Polling Mode** will operate as a **Point-to-Point** polling protocol. This is because the RS-232 transmitter is always left on when enabled.

*Serial Cmd:* **<K148,RES,REQ,STX,ETX,ACK,NAK>**

### D-7-1 RES-NAK Defaults

<i>RES: (Reset)</i>	04
<i>REQ: (Request)</i>	05
<i>STX: (Start of Text)</i>	02
<i>ETX: (End of Text)</i>	03
<i>ACK: (Acknowledge)</i>	06
<i>NAK: (Negative Acknowledge)</i>	15

- **Note:** See **Polling Mode Data Flow Examples** for sample **Polling Mode** communication scenarios.

## D-8 Ethernet

Enables or disables Ethernet connectivity in the reader. This corresponds to the <K126> command. It requires a <Zrdall> to return to default settings.

### D-8-1 IP Address

This is the IP address of the reader when it is in Static IP Address Mode.

### D-8-2 Subnet

This is the subnet of the reader when it is in Static IP Address Mode.

### D-8-3 Gateway

This is the gateway IP address of the reader when it is in Static IP Address Mode.

### D-8-4 IP Address Mode

Determines how the reader's IP address will be defined.

#### Static

In **Static Mode**, the reader uses the user-defined IP address. This is the default state for the MicroHAWK V430-F.

#### DHCP

In **DHCP Mode**, the reader automatically acquires the IP address, Subnet, and Gateway addresses from a DHCP or BOOTP server.

### D-8-5 TCP Port 1

One of two TCP ports for Ethernet communication with the reader. The default setting is **2001**.

### D-8-6 TCP Port 2

One of two TCP ports for Ethernet communication with the reader. The default setting is **2003**.

Changes to this parameter are saved to NOVRAM and are set to default on power on.

A Reset <A> is required for settings to take effect.

- **Important:** Once this setting is Disabled, you will only be able to connect to the reader if you know the IP address and enter it in the IP Address field of the Ethernet TCP/IP connect dialog.

When enabled, **Search and Configure Mode** will find the reader and settings can be changed.

#### Timed Window

When **Timed Window** is selected, Search and Configure Mode will find the reader and settings can be changed, but only 60 seconds from the last reset. After 60 seconds, Search and Configure Mode will be disabled.

## D-9 Response Timeout

---

- Usage:* Only used when a response is required from the host. The reader can be set to wait indefinitely by setting **Response Timeout** to zero.
- Definition:* The time that the reader will wait before timing out if **ACK**, **NAK**, and **ETX** are enabled, and a host response is expected.
- Serial Cmd:* **<K143,response timeout>**
- Default:* **12** (in 1 ms increments)
- Options:* 0 to 255 (A zero (0) setting causes an indefinite wait.)

## D-10 LRC (Longitudinal Redundancy Check) Status

---

- Usage:* Used when extra data integrity is required.
- Definition:* An error-checking routine that verifies the accuracy of transmissions. It is the exclusive OR of all characters following the **STX** (start of text) up to and including the **ETX** (end of text). What this means is that the binary representation of all the characters in a transmission are cumulatively added in a column and each resulting odd integer is assigned a 1 and each even integer a 0 (two 1s = 0, two 0s = 0, a 1 and a 0 = 1). The extra LRC character is then appended to the transmission, and the receiver (usually the host) performs the same addition and compares the results.
- Serial Cmd:* <K145,status>
- Default:* **Disabled**
- Options:* **0 = Disabled**                      1 = Enabled

# D-11 Protocol Configuration Examples

## D-11-1 Point-to-Point (Main Port)

<K100,8,0,1,1> Baud Rate: **115.2K**; Parity: **None**; Stop Bits: **2**; Data Bits: **8**  
 <K140,0> Point-to-Point  
 <K102,0> RS-232 enabled

## D-11-2 Polling Mode (Main Port)

<K100,4,0,1,1> Baud Rate: **9600**; Parity: **None**; Stop Bits: **2**; Data Bits: **8**  
 <K140,5,23> Polling Mode; Address: **23**  
 <K102,0> RS-232 Point-to-Point polling  
 <K143,30> 30 ms Response Timeout

## D-11-3 “User-Defined” Polling Mode (Main Port)

<K100,4,0,1,1> Baud Rate: **9600**; Parity: **None**; Stop Bits: **2**; Data Bits: **8**  
 <K140,5,12> Polling Mode; Address: **12**  
 <K148,,08,09,18,0B,0C,0D> Default RES (0x04), REQ=0x08; EOT=0x09; STX=0x18;  
 ETX=0x0B; ACK=0x0C; NAK=0x0D  
 <K102,0> RS-232 Point-to-Point polling  
 <K143,40> 40 ms Response Timeout

## D-11-4 ACK/NAK (Main Port)

<K100,9,0,1,1> Baud Rate: **230K**; Parity: **None**; Stop Bits: **2**; Data Bits: **8**  
 <K140,4> ACK/NAK  
 <K147,,,01,1B,2E,1F> Default RES and REQ (00, disabled); STX=0x01; ETX=0x1B;  
 ACK=0x2E; NAK=0x1F  
 <K102,0> RS-232 enabled  
 <K143,50> 50 ms Response Timeout



# D-12 Preamble

## D-12-1 Preamble Status

- Usage:* Useful for identifying and controlling incoming data. For example, defining the preamble as a carriage return and a line feed causes each decoded message to be displayed on its own line.
- Definition:* Defines a one to four character data string that can be added to the front of the decoded data.
- Serial Cmd:* <**K141**,*status*,*preamble character(s)*>
- Default:* **Disabled**
- Options:* **0 = Disabled**                      1 = Enabled (within any protocol)

## D-12-2 Preamble Characters

- Serial Cmd:* <**K141**,*status*,*preamble character(s)*>
- Default:* **^M** corresponds to: **carriage return**.
- Options:* To enter control characters within a serial command, hold down the **Ctrl** key while typing the desired character.

*Example:* <**K141**,**1**,**CNTL-m**> to enter the control character **^M**.

## D-13 Postamble

---

### D-13-1 Postamble Status

- Usage:* Useful for identifying and controlling incoming data. For example, defining the postamble as a carriage return and a line feed causes each decoded message to be displayed on its own line.
- Definition:* Allows the user to enable or disable up to four postamble characters that can be added to the end of the decoded data.
- Serial Cmd:* <**K142,status,postamble character(s)**>
- Default:* **Enabled**
- Options:* 0 = Disabled                      1 = **Enabled (within any protocol)**

### D-13-2 Postamble Characters

- Serial Cmd:* <**K142,status,postamble character(s)**>
- Default:* **^M^J** corresponds to: **carriage return/line feed**.
- Options:* To enter control characters within a serial command, hold down the control key while typing the desired character.
- Example:* <**K142,1,CNTL-m CNTL-j**> to enter **^M^J**.

## D-14 USB HID/Keyboard

**Important:** USB HID/Keyboard is available for the V320-F and V420-F only.

**Definition:** These parameters cause the reader to reboot after a <Z> or <A> command. The data packet is structured for input and output as follows:  
 Byte 1 = Report Type (Always 1)  
 Byte 2 = Data Length (Hex Format)  
 Byte 3 – 64 = Data to Command Processor

**Serial Cmd:** <K149,Omron Microscan Report Enabled,Keyboard Report Enabled,Keyboard Language,USB VCOM Status,UART Status>

### D-14-1 Omron Microscan Report Enabled

**Serial Cmd:** <K149,Omron Microscan Report Enabled,Keyboard Report Enabled,Keyboard Language,USB VCOM Status,UART Status>

**Default:** 0 = Disabled

**Options:** 0 = Disabled  
1 = Enabled

### D-14-2 Keyboard Report Enabled

**Serial Cmd:** <K149,Omron Microscan Report Enabled,Keyboard Report Enabled,Keyboard Language,USB VCOM Status,UART Status>

**Default:** 0 = Disabled

**Options:** 0 = Disabled  
1 = Enabled

### D-14-3 Keyboard Language

**Definition:** Used by the reader to help identify what keyboard layout to use when the keyboard drive is outputting data. If the unit does not have the keyboard layout assigned to this parameter, than it will default to the **en-US** keyboard layout. On the next page is the list of acceptable languages with predefined keyboard layouts. If they are pre-loaded into the reader's firmware they are shown in bold. All other languages will need to be manually loaded as a keyboard.def file or added to the reader's firmware.

**Serial Cmd:** <K149,Omron Microscan Report Enabled,Keyboard Report Enabled,Keyboard Language,USB VCOM Status,UART Status>

**Default:** en-US

**Options:** ASCII string, up to 25 characters

## Keyboard Languages

Language	Display Name	Loaded into Firmware
af-ZA	Afrikaans - South Africa	No
sq-AL	Albanian - Albania	No
ar-DZ	Arabic - Algeria	No
ar-BH	Arabic - Bahrain	No
ar-EG	Arabic - Egypt	No
ar-IQ	Arabic - Iraq	No
ar-JO	Arabic - Jordan	No
ar-KW	Arabic - Kuwait	No
ar-LB	Arabic - Lebanon	No
ar-LY	Arabic - Libya	No
ar-MA	Arabic - Morocco	No
ar-OM	Arabic - Oman	No
ar-QA	Arabic - Qatar	No
ar-SA	Arabic - Saudi Arabia	No
ar-SY	Arabic - Syria	No
ar-TN	Arabic - Tunisia	No
ar-AE	Arabic - United Arab Emirates	No
ar-YE	Arabic - Yemen	No
hy-AM	Armenian - Armenia	No
Cy-az-AZ	Azeri (Cyrillic) - Azerbaijan	No
Lt-az-AZ	Azeri (Latin) - Azerbaijan	No
eu-ES	Basque - Basque	No
be-BY	Belarusian - Belarus	No
bg-BG	Bulgarian - Bulgaria	No
ca-ES	Catalan - Catalan	No
zh-CN	Chinese - China	No
zh-HK	Chinese - Hong Kong SAR	No
zh-MO	Chinese - Macau SAR	No
zh-SG	Chinese - Singapore	No
zh-TW	Chinese - Taiwan	No
zh-CHS	Chinese (Simplified)	No
zh-CHT	Chinese (Traditional)	No
hr-HR	Croatian - Croatia	No
cs-CZ	Czech - Czech Republic	No
da-DK	Danish - Denmark	No
div-MV	Dhivehi - Maldives	No
nl-BE	Dutch - Belgium	No
nl-NL	Dutch - The Netherlands	No
en-AU	English - Australia	No
en-BZ	English - Belize	No
en-CA	English - Canada	No
en-CB	English - Caribbean	No
en-IE	English - Ireland	No
en-JM	English - Jamaica	No
en-NZ	English - New Zealand	No
en-PH	English - Philippines	No
en-ZA	English - South Africa	No
en-TT	English - Trinidad and Tobago	No
en-GB	English - United Kingdom	No

en-US	English - United States	Yes
en-ZW	English - Zimbabwe	No
et-EE	Estonian - Estonia	No
fo-FO	Faroese - Faroe Islands	No
fa-IR	Farsi - Iran	No
fi-FI	Finnish - Finland	No
fr-BE	French - Belgium	No
fr-CA	French - Canada	Yes
fr-FR	French - France	No
fr-LU	French - Luxembourg	No
fr-MC	French - Monaco	No
fr-CH	French - Switzerland	No
gl-ES	Galician - Galician	No
ka-GE	Georgian - Georgia	No
de-AT	German - Austria	No
de-DE	German - Germany	No
de-LI	German - Liechtenstein	No
de-LU	German - Luxembourg	No
de-CH	German - Switzerland	No
el-GR	Greek - Greece	No
gu-IN	Gujarati - India	No
he-IL	Hebrew - Israel	No
hi-IN	Hindi - India	No
hu-HU	Hungarian - Hungary	No
is-IS	Icelandic - Iceland	No
id-ID	Indonesian - Indonesia	No
it-IT	Italian - Italy	No
it-CH	Italian - Switzerland	No
ja-JP	Japanese - Japan	No
kn-IN	Kannada - India	No
kk-KZ	Kazakh - Kazakhstan	No
kok-IN	Konkani - India	No
ko-KR	Korean - Korea	No
ky-KZ	Kyrgyz - Kazakhstan	No
lv-LV	Latvian - Latvia	No
lt-LT	Lithuanian - Lithuania	No
mk-MK	Macedonian (FYROM)	No
ms-BN	Malay - Brunei	No
ms-MY	Malay - Malaysia	No
mr-IN	Marathi - India	No
mn-MN	Mongolian - Mongolia	No
nb-NO	Norwegian (Bokmål) - Norway	No
nn-NO	Norwegian (Nynorsk) - Norway	No
pl-PL	Polish - Poland	No
pt-BR	Portuguese - Brazil	No
pt-PT	Portuguese - Portugal	No
pa-IN	Punjabi - India	No
ro-RO	Romanian - Romania	No
ru-RU	Russian - Russia	No
sa-IN	Sanskrit - India	No
Cy-sr-SP	Serbian (Cyrillic) - Serbia	No
Lt-sr-SP	Serbian (Latin) - Serbia	No

sk-SK	Slovak - Slovakia	No
sl-SI	Slovenian - Slovenia	No
es-AR	Spanish - Argentina	No
es-BO	Spanish - Bolivia	No
es-CL	Spanish - Chile	No
es-CO	Spanish - Colombia	No
es-CR	Spanish - Costa Rica	No
es-DO	Spanish - D.R.	No
es-EC	Spanish - Ecuador	No
es-SV	Spanish - El Salvador	No
es-GT	Spanish - Guatemala	No
es-HN	Spanish - Honduras	No
es-MX	Spanish - Mexico	Yes
es-NI	Spanish - Nicaragua	No
es-PA	Spanish - Panama	No
es-PY	Spanish - Paraguay	No
es-PE	Spanish - Peru	No
es-PR	Spanish - Puerto Rico	No
es-ES	Spanish - Spain	No
es-UY	Spanish - Uruguay	No
es-VE	Spanish - Venezuela	No
sw-KE	Swahili - Kenya	No
sv-FI	Swedish - Finland	No
sv-SE	Swedish - Sweden	No
syr-SY	Syriac - Syria	No
ta-IN	Tamil - India	No
tt-RU	Tatar - Russia	No
te-IN	Telugu - India	No
th-TH	Thai - Thailand	No
tr-TR	Turkish - Turkey	No
uk-UA	Ukrainian - Ukraine	No
ur-PK	Urdu - Pakistan	No
Cy-uz-UZ	Uzbek (Cyrillic) - Uzbekistan	No
Lt-uz-UZ	Uzbek (Latin) - Uzbekistan	No
vi-VN	Vietnamese - Vietnam	No

### D-14-4 USB VCOM (Virtual COM) Status

**Definition:** This command enables the **USB Virtual COM Port Driver** if your reader supports the driver. The reader will reset so the driver can be used.

**Serial Cmd:** <K149,Omron Microscan Report Enabled,Keyboard Report Enabled,Keyboard Language,USB VCOM Status,UART Status>

**Options:** **0 = Disabled (Default for V430-F)**  
**1 = Enabled (Default for V420-F)**

### D-14-5 UART Status

**Definition:** This command allows the reader to communicate on the reader's **UART** if the reader is UART-capable. The reader will reset so the UART can be used.

**Serial Cmd:** <K149,Omron Microscan Report Enabled,Keyboard Report Enabled,Keyboard Language,USB VCOM Status,UART Status>

**Options:** **0 = Disabled**  
**1 = Enabled (Default for V420-F, and V430-F)**

## D-15 EtherNet/IP Byte Swapping Enabled

---

*Definition:* Enables or disables EtherNet/IP byte swapping for decode data.

*Serial Cmd:* <**K163,status**>

*Default:* **Disabled**

*Options:* **0 = Disabled**  
1 = Enabled

## D-16 PROFINET

---

*Definition:* Enables or disables the PROFINET communications protocol.

*Serial Cmd:* <**K164,status**>

*Default:* **Disabled**

*Options:* **0 = Disabled**  
1 = Enabled

## D-17 Entering ASCII Characters as Hex Values

---

Commands that require ASCII text fields, such as **Preamble** and **Postamble** commands, can be sent to the reader as hex values.

*Serial Cmd Format:* <Knnnh,00-FF>

To enter ASCII fields as hex values (00 to FF), add a lower-case **h** directly after the command's **K** number, and then enter the hex value that corresponds with the desired ASCII character.

Example:

Consider the **Postamble** command:

*Serial Cmd:* <K142,status,postamble character(s)>

Imagine that your application requires the ASCII character > to be the postamble in your symbol decode output.

The ASCII characters <, >, and , can only be entered as hex values. So, to make > the postamble in your symbol decode output, enter the **Postamble** command as follows:

<K142h,,3E>

Note that the "status" field contains only a , . This is because the only field that is being changed is the "postamble character(s)" field. (See **Serial Configuration Command Conventions** for a more detailed explanation of this command shortcut.)

## D-18 USB Mass Storage Driver

---

**Important:** **USB Mass Storage Driver** is available for the V320-F and V420-F only.

*Definition:* Enables USB MicroHAWK readers to display a Mass Storage device on the host PC.

*Serial Cmd:* **<K900,status>**

*Default:* **Disabled**

*Options:* **0 = Disabled**

**1 = Enabled**



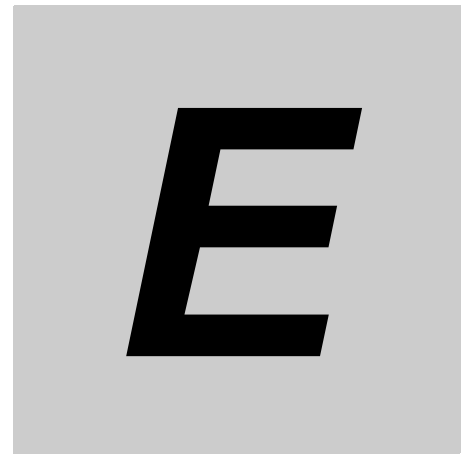

# Calibration

This section shows the calibration options and explains the different ways that those options can be configured.



---

<b>E-1 Calibration Serial Commands</b> .....	<b>E-2</b>
<b>E-2 Calibration Overview</b> .....	<b>E-3</b>
<b>E-3 Calibration Options</b> .....	<b>E-4</b>
<b>E-4 Additional Notes about Calibration</b> .....	<b>E-10</b>

# E-1 Calibration Serial Commands

---

Calibration Options	< <b>K529</b> , <i>gain, exposure, focus position, symbol type, WOI framing, WOI margin, line scan height, processing</i> >
---------------------	---

## E-2 Calibration Overview

---

**Calibration** is one of the most powerful features of the MicroHAWK. The calibration process can be initiated by serial command or in the WebLink user interface.

When the reader enters calibration, it runs through an optimization cycle that sets the ideal parameters for reading symbols at the highest possible level of performance. Calibration can be specially configured to optimize specific parameters, such as gain, exposure, and symbol type.

## E-3 Calibration Options

This command specifies the operation of the calibration feature. The default configuration performs calibration on gain and symbol type. The calibration process optimizes the gain setting for the configured exposure.

### E-3-1 Gain

<i>Definition:</i>	When enabled, gain is calibrated to provide the best available image quality and performance. When disabled, gain is fixed and is not part of the calibration process.
<i>Serial Cmd:</i>	< <b>K529,gain</b> ,exposure,focus position,symbol type,WOI framing,WOI margin,line scan height,processing>
<i>Default:</i>	<b>Quick Calibrate</b>
<i>Options:</i>	0 = Disabled 1 = Enabled (Decode Required) <b>2 = Quick Calibrate</b>

- **Note:** If you choose to calibrate the reader by sending a <@CAL> command, a decode is also required for the calibration process to be completed successfully.

#### Disabled

When disabled, gain is fixed and is not part of the calibration process.

#### Enabled

When enabled, gain is calibrated to provide the best image quality and performance for the symbol present in the field of view. Calibration requires that a decodable symbol be placed in the field of view, as feedback from the symbol decoding process is used to select the best gain setting. If a symbol is not decoded the process will result in a fail condition.

#### Quick Calibrate

**Quick Calibrate** uses the automatic gain control (AGC) feature of the image sensor to adjust the gain value such that the current image falls into a desirable region of the image sensor's sensitivity range, ensuring optimal image luminance. The image sensor converges on the optimal gain value within a few image frames.

## E-3-2 Exposure

**Definition:** Unless the application is static, exposure should be configured based on the application's line speed. The table below is a general guideline for exposure configurations at various line speeds.

**Serial Cmd:** <K529,gain,exposure,focus position,symbol type,WOI framing,WOI margin,line scan height,processing>

**Default:** Quick Calibrate

**Options:** 0 = Disabled  
1 = Enabled (Decode Required)  
**2 = Quick Calibrate**

- **Note:** If you choose to calibrate the reader by sending a <@CAL> command, a decode is also required for the calibration process to be completed successfully.
- **Note:** This table shows guidelines for exposure settings based on various line speeds. The settings shown depend on the reader's optical configuration and on symbol element size.

Exposure	Line Speed
100,000 – 4,000	Static
4,000 – 1,250	5" / sec
1,250 – 700	10" / sec
700 – 500	15" / sec
500 – 400	20" / sec

### Disabled

When disabled, exposure is fixed and is not part of the calibration process.

### Enabled

When enabled, exposure is calibrated to provide the best image quality and performance for the symbol present in the field of view. Calibration requires that a decodable symbol be placed in the field of view, as feedback from the symbol decoding process is used to select the best exposure setting. If a symbol is not decoded the process will result in a fail condition. Exposure is enabled by default.

### Quick Calibrate

**Quick Calibrate** uses the automatic exposure control feature of the image sensor to adjust the exposure value such that the current image falls into a desirable region of the image sensor's sensitivity range, ensuring optimal image luminance. The image sensor converges on the optimal exposure value within a few image frames.



## Enabled

When this feature is enabled, autodiscrimination is in effect during the calibration process. All supported symbologies except PDF417 and Pharmacode will be attempted during calibration. Any new symbologies successfully decoded during calibration will remain enabled at the end of the process. All enabled symbologies will remain enabled. For example, assume that only Code 39 is enabled at the beginning of calibration. If a Code 128 symbol is decoded during calibration, then Code 128 as well as Code 39 will be enabled.

### E-3-5 Window of Interest (WOI) Framing

**Definition:** If WOI Framing is enabled, the camera's Window of Interest will be set to a full size image when calibration begins. Once a symbol is decoded, the camera WOI will be zoomed in both vertically and horizontally (regardless of which WOI mode is enabled) to include the symbol plus an additional margin. This is done to speed up the calibration process. When a successful calibration is complete, the camera WOI will be adjusted according to the mode enabled. Otherwise, the original WOI configuration will be retained.

**Serial Cmd:** <K529,gain,exposure,focus position,symbol type,**WOI framing**,WOI margin, line scan height,processing>

**Default:** Disabled

**Options:** **0 = Disabled**  
 1 = Row and Column  
 2 = Row  
 3 = Column  
 4 = Straight Line  
 5 = Straight Line Framed

If WOI framing is not enabled, the current WOI configuration will be used until a symbol has been decoded. After a symbol is decoded, the WOI is framed exactly as it would be if a WOI framing mode was enabled. When calibration completes, the original WOI configuration is restored.

## Disabled

When this feature is disabled, the Window of Interest is not modified after the calibration process is complete.

## Row and Column

If the calibration process is successful, the Window of Interest will be modified to frame the symbol as well as an additional margin area around the symbol, determined by the **WOI Margin** parameter.

## Row

If the calibration process is successful, the Window of Interest rows will be modified to horizontally frame the symbol, plus an additional margin area around the symbol, determined by the WOI Margin parameter.

## Column

If the calibration process is successful, the Window of Interest columns will be modified to vertically frame the symbol, plus an additional margin area around the symbol, determined by the WOI Margin parameter.

## Straight Line

This feature is intended for use with linear symbologies. If the calibration process is successful, the orientation of the symbol is determined and the Window of Interest is modified according to the symbol orientation. The scan line orientation is determined to be vertical if the symbol tilt is between 225° and 315°, or between 45° and 135°. Otherwise, the scan line will be horizontal.

If the symbol is vertical, the image column size will be set by the scan height parameter, and will be configured for full row resolution. If the symbol is horizontal, the image row size will be set by the scan height parameter, and will be configured for full column resolution. The scan line will be centered in the middle of the symbol. If the symbol is tilted such that the scan line will not pass completely through the symbol, the scan width will be adjusted to include the entire symbol. Refer to the diagram below:



## Straight Line Framed

This parameter is the same as “Straight Line”, except that the Window of Interest will also frame the scan line on the symbol length as well. The scan line includes the symbol plus an additional margin area determined by the WOI Margin parameter.

### E-3-6 Window of Interest (WOI) Margin

<i>Definition:</i>	Sets the margin size that is applied to the calibrated symbol. This parameter is expressed in number of pixels. If the margin causes the image to exceed the maximum image size, it will be reduced accordingly.
<i>Serial Cmd:</i>	< <b>K529</b> ,gain,exposure,focus position,symbol type,WOI framing, <b>WOI margin</b> , line scan height,processing>
<i>Default:</i>	<b>75 (pixels)</b>
<i>Options:</i>	20 to 1280

### E-3-7 Line Scan Height

<i>Definition:</i>	This parameter is only used with the Straight Line modes. It sets the scan height of the straight-line image, and it is expressed in number of pixels.
<i>Serial Cmd:</i>	< <b>K529</b> ,gain,exposure,focus position,symbol type,WOI framing,WOI margin, <b>line scan height</b> ,processing>
<i>Default:</i>	<b>64 (pixels)</b>
<i>Options:</i>	3 to 1280





## E-4 Additional Notes about Calibration

---

The following conditions apply to the reader's calibration process. Some of these items are noted at various points throughout this section, or in other sections of the reader's documentation.

- 1** If **Window of Interest Framing** is enabled, the WOI will be set to full frame when calibration begins. If **WOI Framing** is disabled, the current WOI configuration will be used for the **Search Pass**.
- 2** **Image Processing Mode** will not be altered during calibration.
- 3** If **Symbol Type** is enabled for calibration (**Autodiscriminate**), then Interleaved 2 of 5 **Range Mode Status (Interleaved 2 of 5) <K472>** will be enabled. This allows variable-length Interleaved 2 of 5 symbols to be decoded. If an Interleaved 2 of 5 symbol is decoded during calibration, then code length # 1 will be set to the decoded symbol length at the end of calibration. Otherwise, the symbol lengths will be restored to their original configurations.
- 4** **Pharmacode** is not calibrated.
- 5** All symbol types that were enabled before calibration will still be enabled after calibration. For example, if Data Matrix ECC 200 was enabled before calibration, and the calibration routine was performed on a Code 128 symbol, then after calibration is completed both Data Matrix ECC 200 and Code 128 will be enabled.
- 6** Calibration does not modify the global **Composite** status **<K453>**. The global Composite status must be configured properly before calibration.
- 7** If the user requires calibration of a **stacked** symbology **<K482>**, **<K483>**, or **<K484>**, that symbology must be enabled and configured appropriately before calibration.
- 8** The **Search** process will use the configurable Window of Interest for image captures. However, when the search process is completed, the WOI will be reduced to include only the symbol of interest and some additional boundary area.



# Read Cycle

After you've established communications and completed basic read rate testing, you will need to address the spatial and timing parameters associated with your application. This section explains those parameters.

---

<b>F-1 Read Cycle Serial Commands</b> .....	<b>F-2</b>
<b>F-2 Read Cycle Setup</b> .....	<b>F-3</b>
<b>F-3 Multisymbol</b> .....	<b>F-4</b>
<b>F-4 Trigger Mode and Filter Duration</b> .....	<b>F-5</b>
<b>F-5 External Trigger Polarity</b> .....	<b>F-9</b>
<b>F-6 Serial Trigger</b> .....	<b>F-10</b>
<b>F-7 Start Trigger Character (Non-Delimited)</b> .....	<b>F-11</b>
<b>F-8 Stop Trigger Character (Non-Delimited)</b> .....	<b>F-12</b>
<b>F-9 End of Read Cycle</b> .....	<b>F-13</b>
<b>F-10 Capture Mode</b> .....	<b>F-15</b>
<b>F-11 Capture Timing</b> .....	<b>F-18</b>
<b>F-12 Image Processing Timeout</b> .....	<b>F-19</b>
<b>F-13 Image Storage</b> .....	<b>F-20</b>
<b>F-14 Decodes Before Output</b> .....	<b>F-22</b>

# F-1 Read Cycle Serial Commands

---

Trigger Mode/Filter Duration	<K200,trigger mode,leading edge trigger filter,trailing edge trigger filter>
Serial Trigger Character	<K201,serial trigger character>
External Trigger State	<K202,external trigger state>
End of Read Cycle	<K220,end of read cycle mode,read cycle timeout>
Decodes Before Output	<K221,good decode(s) needed>
Multisymbol	<K222,number of symbols,multisymbol separator>
Start Trigger Character	<K229,start character>
Stop Trigger Character	<K230,stop character>
Capture Mode	<K241,capture mode,number of rapid captures,rapid capture mode,number of continuous captures,images per read cycle limit,read cycle history limit>
Capture Time	<K242,time before first capture,time between captures 1 and 2,time between captures 2 and 3,time between captures 3 and 4,time between captures 4 and 5,time between captures 5 and 6,time between captures 6 and 7,time between captures 7 and 8>
Image Storage	<K244,image storage type,image store mode>
Image Processing Timeout	<K245,image processing timeout>

## F-2 Read Cycle Setup

---

Setting up read cycle and triggering parameters will involve a series of decisions based on your particular application, as follows:

- 1** Select the number of symbols to be read in a single cycle. The reader can read multiple symbols in a single image frame.
- 2** Decide on the trigger type to be used: if serial, choose a serial character; if external, choose either **Level** or **Edge**.
- 3** Designate how the read cycle should end (**Timeout**, **New Trigger**, **Last Frame**).
- 4** Select **Capture Mode**, **Continuous Mode**, or **Rapid Mode**.
- 5** Select **Number of Captures** (if in **Rapid Capture Mode**).
- 6** Set the **Time Before First Capture** and **Time Between Captures**, if any.
  - **Note:** The capture rate increases as the frame size decreases.

## F-3 Multisymbol

- Usage:** Multisymbol is commonly used in shipping applications where a shipping symbol contains individual symbols for part number, quantity, etc. This feature allows on trigger to pick up all the symbols.
- Definition:** **Multisymbol** allows the user to define up to 100 symbols that can be read in a single read cycle.
- Conditions:** The following conditions apply:
- Each symbol must be different to be read, unless in **Rapid Capture Mode**, configured for “triggered capture”.
  - The maximum number of characters in a read cycle is 3,000 for all symbols.
  - All No-Read messages are posted at the end of the data string, unless output filtering is enabled.
  - If more than one symbol is within the field of view at the same time, symbol data may not be displayed in the order of appearance.
  - If **Matchcode Type** is set to **Sequential** or if **Trigger** is set to **Continuous Read 1 Output**, the reader will behave as if **Number of Symbols** were set to 1, regardless of the user-defined configuration.

### F-3-1 Number of Symbols

- Definition:** **Number of Symbols** is the number of different symbols that can be read in a single read cycle.
- Serial Cmd:** `<K222,number of symbols, multisymbol separator>`
- Default:** 1
- Options:** 1 to 100

### F-3-2 Multisymbol Separator

- Usage:** Used to delimit or separate data fields with a user defined character.
- Definition:** Any valid ASCII character, inserted between each symbol read when Multisymbol is set to any number greater than 1.
- Serial Cmd:** `<K222,number of symbols,multisymbol separator>`
- Default:** , (comma)
- Options:** Any available ASCII character.
- **Note:** If No-Read messages are disabled and there are No-Reads occurring, separators will only be inserted between symbol data outputs.

## F-4 Trigger Mode and Filter Duration

### F-4-1 Trigger Mode

*Definition:* The **Trigger** is the event that initiates a read cycle.

**Note:** When calibrating the reader or testing read rate, the current trigger setting will be disregarded.

*Serial Cmd:* <K200,trigger mode,leading edge trigger filter,trailing edge trigger filter>

*Default:* **Continuous Read Auto**

*Options:*

- 0 = Continuous Read
- 1 = Continuous Read 1 Output
- 2 = External Level
- 3 = External Edge
- 4 = Serial Data
- 5 = Serial Data and Edge
- 6 = **Continuous Read Auto**

#### Continuous Read

*Usage:* **Continuous Read** is useful in testing symbol readability or reader functions. It is not recommended for normal operations.

*Definition:* In **Continuous Read**, trigger input options are disabled, the reader is always in the read cycle, and it will attempt to decode and transmit every capture. If a single symbol stays within read range for multiple read cycles, its data will be transmitted repeatedly until it leaves the read range.

The reader sends replies to serial commands that require responses when symbol data is transmitted, or read cycle timeout is enabled and a timeout occurs *and* at least one captured image has been processed. Depending on the combination of enabled symbologies, the reader may take longer than the timeout to process a captured image.

**Note:** When to Output and No-Read options have no affect on **Continuous Read**.

*Serial Cmd:* <K200,0>

#### Continuous Read 1 Output

*Usage:* **Continuous Read 1 Output** can be useful in applications where it is not feasible to use a trigger and all succeeding symbols contain different information. It is also effective in applications where the objects are presented by hand.

*Definition:* In **Continuous Read 1 Output** the reader self-triggers whenever it decodes a new symbol or a timeout occurs.

If **End of Read Cycle** is set to **Timeout** and the symbol doesn't change, the output is repeated at the end of each timeout period. For example, if **Timeout** is set to one second, the reader sends the symbol data immediately and repeats the output at intervals of one second for as long as it continues to capture the symbol.

If **End of Read Cycle** is set to **New Trigger**, the reader will send the current symbol data immediately, *but only once*. A new symbol appearing in the reader's range will be read and sent immediately, provided it is not identical to the previous symbol.

*Serial Cmd:* <K200,1>

- **Caution:** In automated environments, **Continuous Read 1 Output** is not recommended because there is typically no reliable way to verify that a symbol was missed.
- **Note:** If **Trigger Mode** is set to **Continuous Read 1 Output**, the reader will behave as if **Number of Symbols** were set to 1, regardless of the user-defined configuration.

## External Level

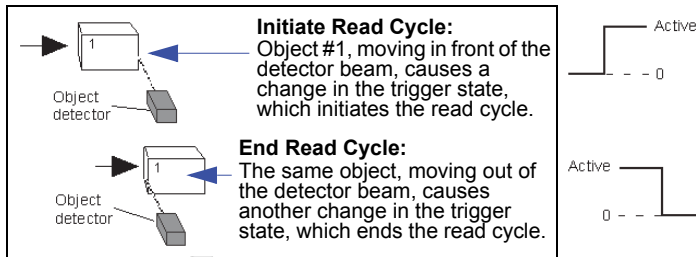

**Usage:** This mode is effective in an application where the speeds of the conveying apparatus are variable and the time the reader spends reading each object is not predictable. It also allows the user to determine if a No-Read has occurred.

**Definition:** **External Level** allows the read cycle (active state) to begin when a trigger (change of state) from an external sensing device is received. The read cycle persists until the object moves out of the sensor range and the active trigger state changes again.

**Serial Cmd:** <K200,2>

- **Important:** **Level** and **Edge** apply to the active logic state (**Active Open** or **Active Closed**) that exists while the object is in a read cycle, between the rising edge and the falling edge. *Rising edge* is the trigger signal associated with the appearance of an object. *Falling edge* is the trigger signal associated with the subsequent disappearance of the object. This applies both to **External Level** and **External Edge**.

## External Edge

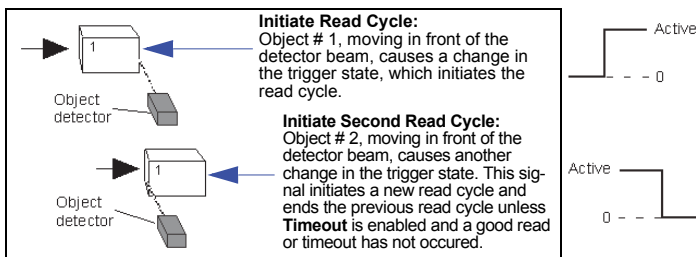

**Usage:** This mode is highly recommended in any application where conveying speed is constant, or if spacing, object size, or read cycle timeouts are consistent.

**Definition:** **External Edge**, as with **Level**, allows the read cycle (active state) to begin when a trigger (change of state) from an external sensing device is received. However, the passing of an object out of sensor range does not end the read cycle. The read cycle ends with a good read output, or, depending on the **End of Read Cycle** setting, a timeout or new trigger occurs.

**Serial Cmd:** <K200,3>



## Serial Data

---

*Usage:* **Serial Data** is effective in a highly controlled environment where the host knows precisely when the object is in the field of view. It is also useful in determining if a No-Read has occurred.

*Definition:* In **Serial Data**, the reader accepts an ASCII character from the host or controlling device as a trigger to start a read cycle. A **Serial Data** trigger behaves the same as an **External Edge** trigger.  
Serial commands are entered inside angle brackets, as shown here: <t>.

*Serial Cmd:* <K200,4>

- **Note:** In **Serial Data**, sending a non-delimited start serial character will start a read cycle; however, a non-delimited stop serial character has no effect.

## Serial Data and Edge

---

*Usage:* **Serial Data or External Edge** is seldom used but can be useful in an application that primarily uses an external sensing device but occasionally needs to be triggered manually.

*Definition:* In this mode the reader accepts either a serial ASCII character or an external trigger pulse to start the read cycle.

*Serial Cmd:* <K200,5>

- **Note:** In **Serial Data**, sending a non-delimited start serial character will start a read cycle; however, a non-delimited stop serial character has no effect.

## Continuous Read Auto

---

*Definition:* Behaves identically to Continuous Read but maintains optimal self-adjusting photometry and focus parameters. As a result, the photometry parameters (Exposure and Gain) in the <K541> command as well as the focus parameter in the <K525> command are continuously updated with the optimal configuration parameters. In this mode, the illumination does not strobe, but instead is always active, as images are continuously captured. If the <K525,,,Auto Focus Mode> field is set to 1, and if there is a series of no-reads, this mode will self-start a focus pass. <K525,,,, # noreads> defines how many no-reads must occur before the focus pass will start.

*Serial Cmd:* <K200,6>

## F-4-2 Leading Edge Trigger Filter

- Usage:* Used to ignore spurious triggers when **Trigger Mode** is set to External Edge or External Level.
- Definition:* To consider a change in state on the trigger input, the level must be stable for the trigger filter duration. In an edge mode, the reader will trigger a read cycle if the active state has been uninterrupted for the entire trigger filter duration. In a level mode, the leading edge is filtered such that on an active edge, the state must be held interrupted for the trigger filter duration before a trigger will occur.
- Serial Cmd:* <**K200**,*trigger mode*,**leading edge trigger filter**,*trailing edge trigger filter*>
- Default:* **1**
- Options:* 1 to 65535 (Trigger filter range: 32.0  $\mu$ s to 2.10 seconds)

## F-4-3 Trailing Edge Trigger Filter

- Usage:* Used to ignore spurious triggers when **Trigger Mode** is set to External Edge or External Level.
- Definition:* To consider a change in state on the trigger input, the level must be stable for the trigger filter duration. In an edge mode, the reader will trigger a read cycle if the active state has been uninterrupted for the entire trigger filter duration. In a level mode, the trailing edge is filtered such that on the falling edge, the state must be held for the trigger filter duration before the trigger will be deemed inactive.
- Serial Cmd:* <**K200**,*trigger mode*,*leading edge trigger filter*,**trailing edge trigger filter**>
- Default:* **1**
- Options:* 1 to 65535 (Trigger filter range: 32.0  $\mu$ s to 2.10 seconds)

## F-5 External Trigger Polarity

---

<i>Usage:</i>	Allows users to select the trigger polarity that will be used in their application.
<i>Definition:</i>	Determines the active state of the trigger signal applied to the cable input of the reader.
<i>Serial Cmd:</i>	< <b>K202,active state</b> >
<i>Default:</i>	<b>Positive</b>
<i>Options:</i>	0 = Negative                      1 = <b>Positive</b>

## F-6 Serial Trigger

---

- Usage:* Allows the user to define the trigger character and delimiters that start and stop the read cycle.
- Definition:* A serial trigger is considered an online host command and requires the same command format as all host commands. It must be entered within angle bracket delimiters < > or, in the case of non-delimited triggers, it must define individual start and stop characters.

### F-6-1 Serial Trigger Character (Delimited)

- Usage:* Allows the user to define the trigger character that initiates the read cycle.
- Definition:* A single ASCII host serial trigger character that initiates the read cycle. A delimited trigger character is one that either starts or ends the read cycle and is enclosed by delimiters such as < >.
- Serial Cmd:* <**K201,serial trigger character**>
- Default:* **Space bar**
- Options:* Any single ASCII character, including control characters, except NUL (0x00 in hex), an existing host command character, or an on-line protocol character. Control characters entered on the command line are displayed in the menu as mnemonic characters.
- **Note:** **Serial Data** or **Serial Data or External Edge** triggering mode must be enabled for **Serial Trigger Character** to take effect.

## F-7 Start Trigger Character (Non-Delimited)

---

- Usage:* Useful in applications where different characters are required to start a read cycle.
- Definition:* A single ASCII host serial trigger character that starts the read cycle and is not enclosed by delimiters such as < and >. Non-delimited **Start** characters can be defined and will function according to the trigger event. When defining **Start** trigger characters, the following rules apply:
- In **External Edge** the reader looks only for the **Start** trigger character and ignores any **Stop** trigger character that may be defined.
  - In **External Level** the **Start** trigger character begins the read cycle and the **Stop** trigger character ends it. Note that even after a symbol has been decoded and the symbol data transmitted, the reader remains in **External Level** trigger read cycle until a **Stop** character is received.
  - In **Serial Data or External Edge** trigger mode, either a **Start** trigger character or a hardware trigger can start an edge trigger read cycle.
- Serial Cmd:* <K229,start character>
- Default:* **NUL** (00 in hex) (disabled)
- Options:* Two hex digits representing any ASCII character except **XON** and **XOFF**.

## F-8 Stop Trigger Character (Non-Delimited)

---

- Usage:* Useful in applications where different characters are required to end a read cycle.
- Definition:* A single ASCII host serial trigger character that ends the read cycle and is not enclosed by delimiters such as < and >. Non-delimited **Stop** characters can be defined and will function according to the trigger event. When defining **Stop** trigger characters, the following rules apply:
- In **External Edge** the reader looks only for the **Start** trigger character and ignores any **Stop** trigger character that may be defined.
  - In **External Level** the **Start** trigger character begins the read cycle and the **Stop** trigger character ends it. Note that even after a symbol has been decoded and the symbol data transmitted, the reader remains in **External Level** trigger read cycle until a **Stop** character is received.
  - In **Serial Data or External Edge** trigger mode, either a **Start** trigger character or a hardware trigger can start an edge trigger read cycle.
- Serial Cmd:* <**K230,stop character**>
- Default:* **NUL** (00 in hex) (disabled)
- Options:* Two hex digits representing an ASCII character.

## F-9 End of Read Cycle

*Definition:* The read cycle is the time during which the reader will attempt to capture and decode a symbol. A read cycle can be ended by a timeout, a new trigger, or by the last frame in a capture sequence or a combination of the above.

### F-9-1 End of Read Cycle Mode

- **Note:** When operating in Continuous Read or Continuous Read 1 Output, the reader is always in the read cycle.

*Serial Cmd:* <K220,end of read cycle,read cycle timeout>

*Default:* **Timeout**

*Options:* **0 = Timeout**  
 1 = New Trigger  
 2 = Timeout or new Trigger  
 3 = Last Frame  
 4 = Last Frame or New Trigger

### Timeout

*Usage:* Typically used with **Serial Data or External Edge** and **Continuous Read 1 Output**.

It is effective in highly controlled applications when the maximum length of time between objects can be predicted. It assures that a read cycle ends before the next symbol appears, giving the system extra time to decode and transmit the data to the host.

*Definition:* **Timeout** ends the read cycle, causing the reader to stop reading symbols and send the symbol data or No-Read message when the time set in **Timeout** elapses (times out), *if When to Output* is set to **End of Read Cycle**.

If in **Continuous Read 1 Output**, a timeout initiates a new read cycle and allows the same symbol to be read again.

With **External Edge**, **Serial Data**, or **Serial Data or External Edge** enabled, a timeout ends the read cycle and symbol data or a No-Read message is sent to the host.

With **External Level** enabled, the read cycle does not end until the falling edge trigger occurs or a timeout occurs. The next read cycle does not begin until the next rising edge trigger.

### New Trigger

*Usage:* **New Trigger** is an effective way to end a read cycle when objects move past the reader at irregular intervals (not timing-dependent).

*Definition:* **New Trigger** ends the current read cycle and initiates a new one when a new trigger occurs. **New Trigger** refers only to a rising edge trigger.

With **External Edge**, **Serial Data**, or **Serial Data or External Edge** enabled, an edge or serial trigger ends a read cycle and initiates the next read cycle.

In the case of **External Level**, a falling edge trigger ends the read cycle but the next read cycle does not begin until the occurrence of the next rising edge trigger.

## Timeout or New Trigger

---

- Usage:* Useful in applications that require an alternative way to end the read cycle. For example, if an assembly line should stop completely or the intervals between objects are highly irregular.
- Definition:* **Timeout or New Trigger** is identical to **Timeout** except that a timeout *or* a new trigger (whichever occurs first) ends the read cycle.

## Last Frame

---

- Usage:* Useful in applications in which the number of captures needed can be defined but the timeout duration varies.
- Definition:* **Last Frame** only applies to **Rapid Capture Mode**.

## Last Frame or New Trigger

---

- Usage:* Useful in applications in which line speeds are irregular and a new labelled object could appear before the last frame in a **Rapid Capture** sequence.
- Definition:* **Last Frame or New Trigger** is identical to **New Trigger** except that a new trigger *or* last frame (whichever occurs first) ends the read cycle.

## Read Cycle Timeout

---

- Definition:* **Read Cycle Timeout** is the duration of the read cycle.
- Serial Cmd:* <K220,end of read cycle,read cycle timeout>
- Default:* **50** (x10 ms)
- Options:* 1 to 65535



# F-10 Capture Mode

**Definition:** **Capture Mode** relates to the way that images are captured and processed.

**Serial Cmd:** <K241,capture mode,number of captures,rapid capture mode,number of continuous captures,images per read cycle limit,read cycle history>

**Default:** **Continuous Capture**

**Options:** 0 = Rapid Capture      1 = **Continuous Capture**

## Rapid Capture

**Definition:** In a rapid capture mode, one or multiple captures can be taken at an interval specified by the time-between-captures parameter. In this mode, the only limiting time factor is integration and transfer timing.

## Continuous Capture

**Usage:** **Continuous Capture** is useful in applications with slower line speeds or where symbol spacing may be random or not time-dependent.

**Definition:** In **Continuous Capture Mode**, image captures are taken throughout the read cycle in a multi-buffered format (see diagram below). The reader begins processing the first captured image at the same time that it captures the second image. Captures will continue occurring throughout the read cycle until an end condition occurs, such as a timeout, a new trigger, the last frame in a capture sequence, or a combination of the above.

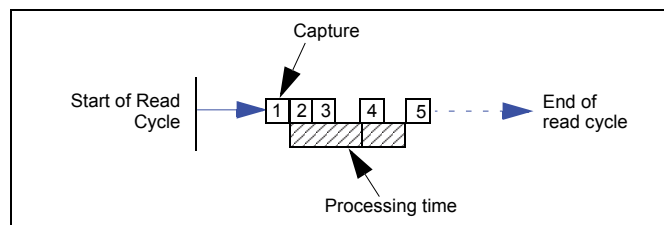

F

### F-10-1 Number of Captures

**Usage:** **Number of Captures** is used to specify the number of captures to be processed in **Rapid Capture Mode**.

**Definition:** Sets the total number of captures that are processed during a read cycle in **Rapid Capture Mode**. This feature is used in conjunction with **Capture Timing** parameters to specify the capture sequence of a rapid capture read cycle.

**Serial Cmd:** <K241,capture mode,number of captures,rapid capture mode,number of continuous captures,images per read cycle limit,read cycle history>

**Default:** 1

**Options:** 1 to 255

## F-10-2 Rapid Capture Mode

**Definition:** In **Rapid Capture Mode**, one or multiple captures (as many as 32) can be taken at an interval specified by the time-between-captures parameter. In this mode, the only limiting time factor is integration and transfer timing.

**Serial Cmd:** <K241,capture mode,number of captures,rapid capture mode,number of continuous captures,images per read cycle limit,read cycle history>

**Default:** **Timed Capture**

**Options:** **0 = Timed Capture**      **1 = Triggered Capture**

### Timed Capture

**Usage:** **Timed Rapid Capture** is useful in fast-moving applications in which symbols are only in the field of view for a short time and precise timing is required.

**Definition:** In **Timed Rapid Capture**, decoding occurs independent of and simultaneous with capturing, thus allowing precise timing or no delay at all between captures.

Also, consecutive captures are regarded as the same symbol if the output data is the same.

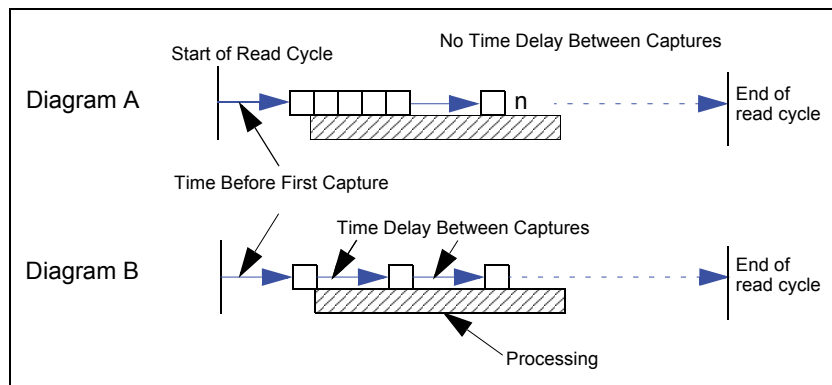

### Triggered Capture

**Usage:** Useful in applications where each decode must be treated as a discrete event, regardless of symbol data.

**Definition:** The first trigger event starts the read cycle, and subsequent triggers will continue until the predetermined **Number of Captures** is met, or until the predetermined **End of Read Cycle** condition is met— whichever occurs first.

**Note:** If **End of Read Cycle** is set for **New Trigger** and the read cycle qualifications have not been met, the read cycle will only end *once it receives the first trigger after reaching the predetermined **Number of Captures** setting.*

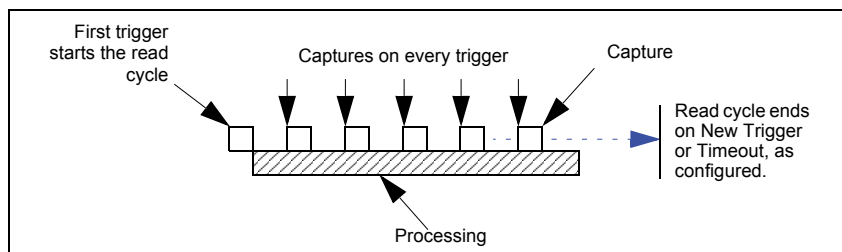

### F-10-3 Number of Continuous Captures

*Definition:* Specifies the number of captures to process in Continuous Capture mode.  
*Serial Cmd:* <K241,capture mode,number of captures,rapid capture mode,**number of continuous captures**,images per read cycle limit,read cycle history>  
*Default:* 2  
*Options:* 1 and 255

### F-10-4 Images per Read Cycle Limit

*Definition:* Specifies the number of captures to process in a read cycle.  
*Serial Cmd:* <K241,capture mode,number of captures,rapid capture mode,number of continuous captures,**images per read cycle limit**,read cycle history>  
*Default:* 10  
*Options:* 3 and 255

### F-10-5 Read Cycle History

*Definition:* Specifies the number of images that can be stored in read cycle history.  
*Serial Cmd:* <K241,capture mode,number of captures,rapid capture mode,number of continuous captures,**images per read cycle limit**,read cycle history>  
*Default:* 10  
*Options:* 0 and 255

F

# F-11 Capture Timing

- **Note:** Capture Timing applies only to **Rapid Capture Mode**.

## F-11-1 Time Before First Capture

**Usage:** In almost any moving line application, a time delay is needed to ensure that a symbol will be in the reader's field of view at the beginning of the capture sequence.

**Definition:** **Time Before First Capture** in a moving line application is the time between an external trigger event and the occurrence of the first capture.

**Serial Cmd:** <K242,time before 1st capture,time between capture 1 and capture 2,,,,,,time between capture 7 and capture 8>

**Default:** 0

**Options:** 0 to 65535 (2.097 seconds, in 32 μS increments)

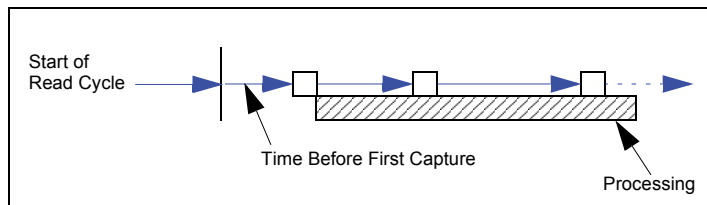

## F-11-2 Time Between Captures

**Usage:** This is useful in applications where more than one symbol can appear during a single read cycle (multisymbol), or where line speeds are slow enough that captured frames might overlap or miss a symbol.

**Definition:** A time delay can be inserted between individual frame captures in **Rapid Capture Mode**.

**Serial Cmd:** <K242,time before 1st capture,time between captures [time 1,time 2,...time7]>

Entering 0s will result in no time between captures.

Entering a different value in each field will vary the time delays accordingly.

**Note:** You must enter time values along with comma separators for each field you want to change. If you omit fields, or enter only commas, the fields will remain as previously set.

**Important:** If the reader is configured to capture more than 8 images, the last (or 8th) delay value will be repeated for the remaining captures.

**Default:** 0

**Options:** 0 to 65535 (2.097 seconds, in 32 μS increments)

- **Note:** **Number of Captures** and number of frame delays (**Time Between Captures**) must be the same.

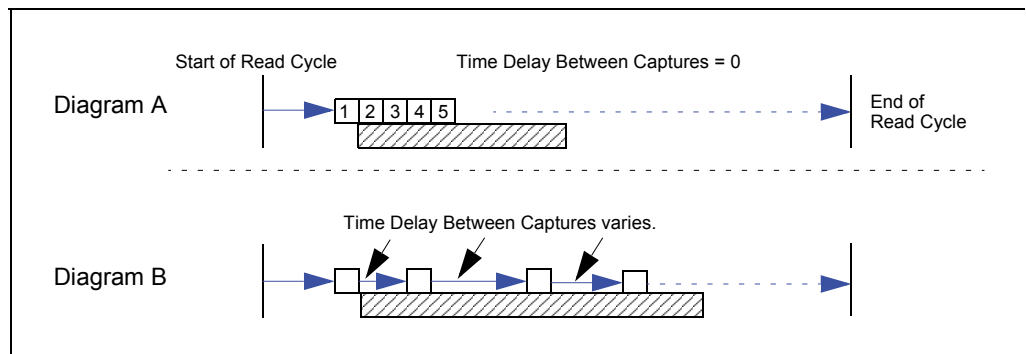

## F-12 Image Processing Timeout

---

<i>Usage:</i>	Useful in higher speed applications where image processing time is long enough that not all captures have an opportunity to be processed.
<i>Definition:</i>	Specifies the maximum amount of time to process a captured image. When the timeout expires, the image processing is aborted. This timeout works in both <b>Rapid Capture</b> and <b>Continuous Capture</b> modes, as well as with the Configuration Database.
<i>Serial Cmd:</i>	< <b>K245,image processing timeout</b> >
<i>Default:</i>	<b>5000 ms</b> (5 sec.)
<i>Options:</i>	1 to 65535 (in 1 ms increments)

**Notes:**

- The timeout period does not include capture time.
- If a timeout occurs during processing and no symbols in the field of view have been decoded, the image will be recorded as a No-Read. For this reason, a longer timeout should be tried to ensure that the symbol is decoded successfully.

# F-13 Image Storage

## F-13-1 Image Storage Type

**Definition:** Allows the user to store images from separate read cycles and to retrieve them later. The number of available slots for storage depends on the mode of operation. If the reader is in **Rapid Capture Mode**, the number of images that can be stored is equivalent to the maximum number of the rapid count (the current rapid count setting). If the reader is in **Continuous Capture Mode**, a number of images equivalent to the maximum number of the rapid count minus 3.

**Serial Cmd:** <K244,*image storage type,image storage mode*>

**Default:** Disabled/Clear

**Options:** 0 = Disabled/Clear                      1 = Store on No-Read

### Disabled/Clear

Upon selection of this option, all saved images will be cleared and the reader will not store images for later viewing.

### Store on No-Read

This option will cause the reader to store an image upon exiting the read cycle for retrieval at a later time. If multiple captures are present during the duration of a read cycle, the stored image will be the last image processed for that read cycle. This image is stored in RAM and can be retrieved as long as power is cycled to the reader, and as long as the reader has not been reset via a reset/save sequence. Other commands that can initialize storage in RAM are ones that change capture modes or put the reader in a test capture mode.

## F-13-2 Image Storage Mode

**Serial Cmd:** <K244,*image storage type,image storage mode*>

**Default:** First Mode

**Options:** 0 = First Mode                      1 = Last Mode

### First Mode

This mode allows the reader to store images until the available image memory has been filled. At that point the reader will stop saving additional images. In this mode, you will always have the first image captured, because the saving process stops once memory has been filled.

### Last Mode

In this mode, image storage continues after available memory limits are reached. The oldest image in memory is overwritten, so you will always have the most recent stored image.

### F-13-3 Image Storage Example

The following example assumes that the reader is in a rapid capture mode of 3 captures.

**Number of Symbols:** 1  
**Frame # 1:** No-Read  
**Frame # 2:** No-Read  
**Frame # 3:** Good Read, Symbol # 1  
**Read Cycle Result:** Good Read  
**Stored Frame:** None

**Number of Symbols:** 1  
**Frame # 1:** No-Read  
**Frame # 2:** No-Read  
**Frame # 3:** No-Read  
**Read Cycle Result:** No-Read  
**Stored Frame:** Frame # 3

**Number of Symbols:** 2  
**Frame # 1:** No-Read  
**Frame # 2:** No-Read  
**Frame # 3:** Good Read, Symbol # 1  
**Read Cycle Result:** No-Read  
**Stored Frame:** Frame # 2

# F-14 Decodes Before Output

---

## F-14-1 Good Decode(s) Needed

<i>Definition:</i>	This value specifies the number of times a symbol needs to be read to qualify as a good read.
<i>Serial Cmd:</i>	< <b>K221,good decode(s) needed</b> >
<i>Default:</i>	<b>1</b>
<i>Options:</i>	1 to 255





# Symbologies

This section describes how to configure the MicroHAWK to decode a wide variety of linear, 2D, and stacked symbologies.

---

<b>G-1 Symbologies Serial Commands</b> .....	<b>G-2</b>
<b>G-2 Data Matrix</b> .....	<b>G-3</b>
<b>G-3 Aztec</b> .....	<b>G-5</b>
<b>G-4 QR Code</b> .....	<b>G-6</b>
<b>G-5 Micro QR Code</b> .....	<b>G-7</b>
<b>G-6 Code 39</b> .....	<b>G-8</b>
<b>G-7 Code 128/EAN 128</b> .....	<b>G-10</b>
<b>G-8 BC412</b> .....	<b>G-12</b>
<b>G-9 Interleaved 2 of 5</b> .....	<b>G-13</b>
<b>G-10 Code 93</b> .....	<b>G-15</b>
<b>G-11 Codabar</b> .....	<b>G-16</b>
<b>G-12 UPC/EAN</b> .....	<b>G-18</b>
<b>G-13 Pharmacode</b> .....	<b>G-21</b>
<b>G-14 Postal Symbologies</b> .....	<b>G-23</b>
<b>G-15 GS1 DataBar</b> .....	<b>G-26</b>
<b>G-16 PDF417</b> .....	<b>G-27</b>
<b>G-17 MicroPDF417</b> .....	<b>G-28</b>
<b>G-18 Composite</b> .....	<b>G-29</b>
<b>G-19 DotCode</b> .....	<b>G-30</b>

# G-1 Symbologies Serial Commands

Composite	<K453,symbology status,separator status,separator character>
Aztec	<K458,status>
Micro QR Code	<K459,status>
Postal Symbologies	<K460,postal symbology type,POSTNET status,PLANET status,USPS4CB status>
Code 39	<K470,status,check character status,check character output status, large intercharacter gap,fixed symbol length status, fixed symbol length,full ASCII set>
Codabar	<K471,status,start/stop match,start/stop output,large intercharacter gap,fixed symbol length status,symbol length,check character type,check character output>
Interleaved 2 of 5	<K472,status,check character status,check character output status, symbol length #1, symbol length #2, guard bar status, range mode status>
UPC/EAN	<K473,UPC status,EAN status,supplemental status,separator status, separator character,supplemental type,format UPC-E as UPC-A>
Code 128/EAN 128	<K474,status,fixed symbol length status,fixed symbol length,EAN 128 status,output format,application record separator status,application record separator character,application record brackets,application record padding>
Code 93	<K475,status,fixed symbol length status,symbol length>
PDF417	<K476,status,unused,fixed symbol length status,symbol length>
Pharmacode	<K477,status,fixed bar count status,fixed bar count,minimum bar count,bar width mode,direction,fixed threshold value,background color>
Data Matrix	<K479,ECC 200 status, ECC 000 status,ECC 050 status, ECC 080 status,ECC 100 status,ECC 140 status,ECC 120 status,ECC 130 status>
QR Code	<K480,status>
BC412	<K481,status,check character output,fixed symbol length status, fixed symbol length>
DataBar-14	<K482,status>
DataBar Limited	<K483,status>
DataBar Expanded	<K484,status,fixed symbol length status,fixed symbol length>
MicroPDF417	<K485,status,[unused],fixed symbol length status,fixed symbol length>
DotCode	<K497,status,rotation mode>

## G-2 Data Matrix

**Usage:** Very useful where information needs to be packed into a small area, and/or where symbols need to be applied directly to the substrate with laser etching, chemical etching, dot peen, or other methods.

**Definition:** Data Matrix is a type of Matrix symbology and has subsets ECC 000 - ECC 200. ECC 200 symbols have an even number of rows and an even number of columns. Most of the symbols are square with sizes from 10x10 to 144x144. Some symbols, however, are rectangular, with sizes from 8x18 to 16x48. All ECC 200 symbols can be recognized by the upper right corner module being light (binary 0) instead of dark.

### G-2-1 ECC 200

**Definition:** When enabled, will decode ECC 200 Data Matrix symbols.

**Serial Cmd:** <**K479**,**ECC 200 status**,**ECC 000 status**,**ECC 050 status**,**ECC 080 status**,**ECC 100 status**,**ECC 140 status**,**ECC 120 status**,**ECC 130 status**>

**Default:** **Enabled**

**Note:** This is the only symbol type enabled by default.

**Options:** 0 = Disabled                      1 = **Enabled**

### G-2-2 ECC 000

**Definition:** When enabled, will decode ECC 000 symbols.

**Serial Cmd:** <**K479**,**ECC 200 status**,**ECC 000 status**,**ECC 050 status**,**ECC 080 status**,**ECC 100 status**,**ECC 140 status**,**ECC 120 status**,**ECC 130 status**>

**Default:** **Disabled**

**Options:** 0 = **Disabled**                      1 = Enabled

### G-2-3 ECC 050

**Definition:** When enabled, will decode ECC 050 symbols.

**Serial Cmd:** <**K479**,**ECC 200 status**,**ECC 000 status**,**ECC 050 status**,**ECC 080 status**,**ECC 100 status**,**ECC 140 status**,**ECC 120 status**,**ECC 130 status**>

**Default:** **Disabled**

**Options:** 0 = **Disabled**                      1 = Enabled

### G-2-4 ECC 080

**Definition:** When enabled, will decode ECC 080 symbols.

**Serial Cmd:** <**K479**,**ECC 200 status**,**ECC 000 status**,**ECC 050 status**,**ECC 080 status**,**ECC 100 status**,**ECC 140 status**,**ECC 120 status**,**ECC 130 status**>

**Default:** **Disabled**

**Options:** 0 = **Disabled**                      1 = Enabled

### G-2-5 ECC 100

**Definition:** When enabled, will decode ECC 100 symbols.

**Serial Cmd:** <**K479**,**ECC 200 status**,**ECC 000 status**,**ECC 050 status**,**ECC 080 status**,**ECC 100 status**,**ECC 140 status**,**ECC 120 status**,**ECC 130 status**>

**Default:** **Disabled**

**Options:** 0 = **Disabled**                      1 = Enabled

## G-2-6 ECC 140

*Definition:* When enabled, will decode ECC 140 symbols.  
*Serial Cmd:* <**K479**,ECC 200 status,ECC 000 status,ECC 050 status,ECC 080 status,  
 ECC 100 status,**ECC 140 status**,ECC 120 status,ECC 130 status>  
*Default:* **Disabled**  
*Options:* **0 = Disabled**                      1 = Enabled

## G-2-7 ECC 120

*Definition:* When enabled, will decode ECC 120 symbols.  
*Serial Cmd:* <**K479**,ECC 200 status,ECC 000 status,ECC 050 status,ECC 080 status,  
 ECC 100 status,ECC 140 status,**ECC 120 status**,ECC 130 status>  
*Default:* **Disabled**  
*Options:* **0 = Disabled**                      1 = Enabled

## G-2-8 ECC 130

*Definition:* When enabled, will decode ECC 130 symbols.  
*Serial Cmd:* <**K479**,ECC 200 status,ECC 000 status,ECC 050 status,ECC 080 status,  
 ECC 100 status,ECC 140 status,ECC 120 status,**ECC 130 status**>  
*Default:* **Disabled**  
*Options:* **0 = Disabled**                      1 = Enabled

## G-3 Aztec

---

- Usage:* Used in document imaging, railway ticket validation, and some postal applications.
- Definition:* A 2D matrix symbology built on a square grid with a square “bull’s-eye” pattern at the center. **Aztec** can encode up to 3,832 numeric or 3,067 alphabetical characters, or 1,914 bytes of data.  
The level of Reed-Solomon error correction used with Aztec is configurable, from 5% to 95% of the total data region. The recommended error correction level is 23% of symbol capacity plus codewords.
- Serial Cmd:* <**K458,status**>
- Default:* **Disabled**
- Options:* **0 = Disabled**                      1 = Enabled

## G-4 QR Code

---

*Usage:* Widely implemented in the automotive industry in Japan and throughout their worldwide supply chain.

*Definition:* QR Code is capable of handling numeric, alphanumeric, and byte data as well as kanji and kana characters. Up to 7,366 characters (numeric data) can be encoded using this symbol. Therefore, less space is required to encode the same amount of data in a QR Code symbol than in a conventional symbol, lowering the cost of labelling.

Three Position Detection Patterns in the symbol make omnidirectional, ultra-fast reading possible.

QR Code has error protection capability. Data can often be restored even if a part of the symbol has become dirty or damaged.

*Serial Cmd:* **<K480,status>**

*Default:* **Enabled**

*Options:* **0 = Disabled**                      1 = Enabled

## G-5 Micro QR Code

---

- Usage:* Used in various applications that require higher data density than that provided by standard QR Code. Some application examples are automotive inventory, vehicle ID, and mobile phone URL encodation.
- Definition:* **Micro QR Code** is a 2D matrix symbology that comes in 4 different symbol sizes, the largest capable of encoding 35 numeric characters.
- Serial Cmd:* **<K459,status>**
- Default:* **Enabled**
- Options:* **0 = Disabled**                      1 = Enabled

## G-6 Code 39

**Usage:** **Code 39** is considered the standard for non-retail 1D symbology.

**Definition:** An alphanumeric symbology with unique start/stop code patterns, composed of 9 black and white elements per character, of which 3 are wide.

**Serial Cmd:** *<K470,status,check character status,check character output status,large intercharacter gap,fixed symbol length status,fixed symbol length,full ASCII set>*

**Default:** **Enabled**

**Options:** 0 = Disabled                      1 = Enabled

### G-6-1 Check Character Status (Code 39)

**Serial Cmd:** *<K470,status,check character status,check character output status,large intercharacter gap,fixed symbol length status,fixed symbol length,full ASCII set>*

**Default:** **Disabled**

**Options:** **0 = Disabled**                      1 = Enabled

### G-6-2 Check Character Output Status (Code 39)

**Usage:** **Check Character Output Status**, added to the symbol, provides additional data security.

**Definition:** When enabled, the check character character is read and compared along with the symbol data. When disabled, symbol data is sent without the check character.

**Note:** With **Check Character Output Status** and an **External** or **Serial** trigger option enabled, an invalid check character calculation will cause a No-Read message to be transmitted at the end of the read cycle.

**Serial Cmd:** *<K470,status,check character status,check character output status,large intercharacter gap,fixed symbol length status,fixed symbol length,full ASCII set>*

**Default:** **Disabled**

**Options:** **0 = Disabled**                      1 = Enabled

### G-6-3 Large Intercharacter Gap (Code 39)

**Usage:** **Large Intercharacter Gap** is helpful for reading symbols that are printed out of specification.

**Definition:** When enabled, the reader can read symbols with gaps between symbol characters that exceed three times (3x) the narrow element width.

**Serial Cmd:** *<K470,status,check character status,check character output status,large intercharacter gap,fixed symbol length status,fixed symbol length,full ASCII set>*

**Default:** **Disabled**

**Options:** **0 = Disabled**                      1 = Enabled



## G-6-4 Fixed Symbol Length Status (Code 39)

- Definition:** When enabled, the reader will check the symbol length against the symbol length field. If disabled, any length will be considered valid.
- Serial Cmd:** <K470,status,check character status,check character output status,large intercharacter gap,fixed symbol length status,fixed symbol length,full ASCII set>
- Default:** Disabled
- Options:** 0 = Disabled                      1 = Enabled

## G-6-5 Fixed Symbol Length (Code 39)

- Usage:** **Fixed Symbol Length** helps prevent truncations and increases data integrity by ensuring that only one symbol length will be accepted.
- Definition:** Specifies the exact number of characters that the reader will recognize (this does not include start and stop and check characters). The reader ignores any symbology that does not match the specified length.
- Serial Cmd:** <K470,status,check character status,check character output status,large intercharacter gap,fixed symbol length status,fixed symbol length,full ASCII set>
- Default:** 10
- Options:** 1 to 64

## G-6-6 Full ASCII Set (Code 39)

- Usage:** Must be enabled when reading characters outside the standard character set (0-9, A-Z, etc.)  
The user must know in advance whether or not to use the **Full ASCII Set** option. Since **Full ASCII Set** requires two code words to encode one character, it is less efficient.
- Definition:** Standard Code 39 encodes 43 characters; zero through nine, capital "A" through capital "Z", minus symbol, plus symbol, forward slash, space, decimal point, dollar sign, and percent symbol. When **Full ASCII Set** is enabled, the reader can read the full ASCII character set, from 0 to 255.
- Serial Cmd:** <K470,status,check character status,check character output status,large intercharacter gap,fixed symbol length status,fixed symbol length,full ASCII set>
- Default:** Disabled
- Options:** 0 = Disabled                      1 = Enabled

## G-7 Code 128/EAN 128

- Usage:** **Code 128** is a smaller symbology useful in applications with tight spots and high security needs.
- Definition:** A very dense alphanumeric symbology. It encodes all 128 ASCII characters, it is continuous, has variable length, and uses multiple element widths measured edge to edge.
- Serial Cmd:** <**K474,status,fixed symbol length status,fixed symbol length,EAN 128 status,output format,application record separator status,application record separator character,application record brackets,application record padding**>
- Default:** **Enabled**
- Options:** 0 = Disabled                      1 = Enabled

### G-7-1 Fixed Symbol Length Status (Code 128/EAN 128)

- Definition:** When enabled, the reader will check the symbol length against the symbol length field. If disabled, any length will be considered a valid symbol.
- Serial Cmd:** <**K474,status,fixed symbol length status,fixed symbol length,EAN 128 status,output format,application record separator status,application record separator character,application record brackets,application record padding**>
- Default:** **Disabled**
- Options:** 0 = Disabled                      1 = Enabled

### G-7-2 Fixed Symbol Length (Code 128/EAN 128)

- Usage:** **Fixed Symbol Length** helps prevent truncations and increases data integrity by ensuring that only one symbol length will be accepted.
- Definition:** This specifies the exact number of characters that the reader will recognize (this does not include start, stop, and check characters). The reader ignores any symbol not having the specified length.
- Serial Cmd:** <**K474,status,fixed symbol length status,fixed symbol length,EAN 128 status,output format,application record separator status,application record separator character,application record brackets,application record padding**>
- Default:** **10**
- Options:** 1 to 64

### G-7-3 EAN 128 Status (Code 128/EAN 128)

- Definition:** When this field is disabled, the reader will not check any Code 128 labels for conformance to EAN requirements, or perform any special formatting. When enabled, the reader can read symbols with or without a function 1 character in the first position. If a symbol has a function 1 character in the first position, it must conform to EAN format. Symbols that conform to EAN format will also be subject to the special output formatting options available in this command.
- If EAN status is required, the reader will only decode symbols that have a function 1 character in the first position and that conform to EAN format. All symbols read will be subject to the special output formatting options available in this command.
- Note:** Code 128 status must be enabled for EAN status to be active.
- Serial Cmd:** <**K474,status,fixed symbol length status,fixed symbol length,EAN 128 status,output format,application record separator status,application record separator character,application record brackets,application record padding**>
- Default:** **Disabled**
- Options:** 0 = Disabled                      1 = Enabled                      2 = Required

## G-7-4 Output Format (Code 128/EAN 128)

- Definition:** In **Standard**, the reader will not apply special EAN output formatting options.  
In **Application**, the reader will apply the special EAN output formatting options to decoded EAN-conforming symbols.
- Serial Cmd:** <**K474**,*status, fixed symbol length status, fixed symbol length, EAN 128 status, output format, application record separator status, application record separator character, application record brackets, application record padding*>
- Default:** **Standard**
- Options:** **0 = Standard**                      1 = Application

## G-7-5 Application Record Separator Status (Code 128/EAN 128)

- Definition:** When enabled, an EAN separator will be inserted into the output between fields whenever an EAN-conforming symbol is decoded and EAN output formatting applies.
- Serial Cmd:** <**K474**,*status, fixed symbol length status, fixed symbol length, EAN 128 status, output format, application record separator status, application record separator character, application record brackets, application record padding*>
- Default:** **Disabled**
- Options:** **0 = Disabled**                      1 = Enabled

## G-7-6 Application Record Separator Character (Code 128/EAN 128)

- Definition:** This is an ASCII character that serves as an EAN separator in formatted EAN output.
- Serial Cmd:** <**K474**,*status, fixed symbol length status, fixed symbol length, EAN 128 status, output format, application record separator status, application record separator character, application record brackets, application record padding*>
- Default:** ,
- Options:** Any ASCII character (7 bit)

## G-7-7 Application Record Brackets (Code 128/EAN 128)

- Definition:** If an EAN-conforming symbol is decoded and EAN formatting applies, this feature places bracket characters around the application identifiers in the formatted output.
- Serial Cmd:** <**K474**,*status, fixed symbol length status, fixed symbol length, EAN 128 status, output format, application record separator status, application record separator character, application record brackets, application record padding*>
- Default:** **Disabled**
- Options:** **0 = Disabled**                      1 = Enabled

## G-7-8 Application Record Padding (Code 128/EAN 128)

- Definition:** This feature causes the reader to pad variable-length application fields with leading zeroes. This is not done for the last field of a symbol.
- Serial Cmd:** <**K474**,*status, fixed symbol length status, fixed symbol length, EAN 128 status, output format, application record separator status, application record separator character, application record brackets, application record padding*>
- Default:** **Disabled**
- Options:** **0 = Disabled**                      **1 = Enabled**

## G-8 BC412

<i>Usage:</i>	Widely used in semiconductor manufacturing. Particularly useful where speed, accuracy, and ease of printing are required.	
<i>Definition:</i>	BC412 (Binary Code 412), a proprietary IBM symbology since 1988, is an alphanumeric symbol with a set of 35 characters, each encoded by a set of 4 bars in 12 module positions. All bars have a single width; it is the presence (1) or absence (0) of bars in each of the twelve module positions that make BC412 binary. This symbology is also bi-directional and self-clocking, with a start character and a stop character.	
<i>Serial Cmd:</i>	< <b>K481,status,check character output,fixed symbol length status,fixed symbol length</b> >	
<i>Default:</i>	<b>Disabled</b>	
<i>Options:</i>	<b>0 = Disabled</b>	1 = Enabled

### G-8-1 Check Character Output (BC412)

<i>Usage:</i>	<b>Check Character Output</b> , added to the symbol, provides additional security.	
<i>Definition:</i>	When enabled, the check character is read and compared along with the symbol data. When disabled, symbol data is sent without the check character.	
<i>Serial Cmd:</i>	< <b>K481,status,check character output,fixed symbol length status,fixed symbol length</b> >	
<i>Default:</i>	<b>Disabled</b>	
<i>Options:</i>	<b>0 = Disabled</b>	1 = Enabled

### G-8-2 Fixed Symbol Length Status (BC412)

<i>Definition:</i>	When enabled, the reader will check the symbol length against the symbol length field. If disabled, any length will be considered valid.	
<i>Serial Cmd:</i>	< <b>K481,status,check character output,fixed symbol length status,fixed symbol length</b> >	
<i>Default:</i>	<b>Disabled</b>	
<i>Options:</i>	<b>0 = Disabled</b>	1 = Enabled

### G-8-3 Fixed Symbol Length (BC412)

<i>Definition:</i>	When enabled, the check character is read and compared along with the symbol data. When disabled, symbol data is sent without the check character.	
<i>Serial Cmd:</i>	< <b>K481,status,check character output,fixed symbol length status,fixed symbol length</b> >	
<i>Default:</i>	<b>10</b>	
<i>Options:</i>	1 to 64	

## G-9 Interleaved 2 of 5

<i>Usage:</i>	I-2/5 has been popular because it is the most dense symbology for printing numeric characters less than 10 characters in length; however, Omron Microscan does not recommend this symbology for any new applications because of inherent problems such as truncation.
<i>Definition:</i>	A dense, continuous, self-checking, numeric symbology. Characters are paired together so that each character has five elements, two wide and three narrow, representing numbers 0 through 9, with the bars representing the first character and the interleaved spaces representing the second character. (A check character is highly recommended). <b>Important:</b> You must set Symbol Length in order to decode I-2/5 symbols, unless <b>Range Mode</b> is enabled.
<i>Serial Cmd:</i>	< <b>K472,status,check character status,check character output status,symbol length #1,symbol length #2,guard bar status,range mode status</b> >
<i>Default:</i>	<b>Enabled</b>
<i>Options:</i>	0 = Disabled                      1 = <b>Enabled</b>

### G-9-1 Check Character Status (Interleaved 2 of 5)

<i>Usage:</i>	This option is not typically used, but it can be enabled for additional security in applications where the host requires redundant check character verification.
<i>Definition:</i>	An error correcting routine in which the check character is added.
<i>Serial Cmd:</i>	< <b>K472,status,check character status,check character output status,symbol length #1,symbol length #2,guard bar status,range mode status</b> >
<i>Default:</i>	<b>Disabled</b>
<i>Options:</i>	0 = <b>Disabled</b> 1 = Enabled

### G-9-2 Check Output Status (Interleaved 2 of 5)

<i>Definition:</i>	When enabled, a check character is sent along with the symbol data for added data security.
<i>Serial Cmd:</i>	< <b>K472,status,check character status,check character output status,symbol length #1,symbol length #2,guard bar status,range mode status</b> >
<i>Default:</i>	<b>Disabled</b>
<i>Options:</i>	0 = <b>Disabled</b> 1 = Enabled

### G-9-3 Symbol Length #1 (Interleaved 2 of 5)

<i>Usage:</i>	Useful in applications where I 2/5 symbols of a specific length are required.
<i>Definition:</i>	The <b>Symbol Length # 1</b> field is one of two fields against which the decoded symbol is compared before accepting it as valid or rejecting it.
<i>Serial Cmd:</i>	< <b>K472,status,check character status,check character output,symbol length #1,symbol length #2,guard bar status,range mode status</b> >
<i>Default:</i>	<b>16</b>
<i>Options:</i>	0 to 64, even only <b>Important:</b> If <b>Range Mode</b> is disabled, the length of the symbol must match either <b>Symbol Length # 1</b> or <b>Symbol Length # 2</b> to be considered a valid symbol. If <b>Range Mode</b> is enabled, <b>Symbol Length # 1</b> and <b>Symbol Length # 2</b> form a range into which the length of the symbol must fall to be considered valid.

### G-9-4 Symbol Length #2 (Interleaved 2 of 5)

- Usage:** Useful in applications where I 2/5 symbols of a specific length are required.
- Definition:** The **Symbol Length # 2** field is one of two fields against which the decoded symbol is compared before accepting it as valid or rejecting it.
- Serial Cmd:** <K472,status,check character status,check character output,symbol length #1,symbol length #2,guard bar status,range mode status>
- Default:** 6
- Options:** 0 to 64, even only
- Important:** If **Range Mode** is disabled, the length of the symbol must match either **Symbol Length # 2** or **Symbol Length # 1** to be considered a valid symbol.
- If **Range Mode** is enabled, **Symbol Length # 2** and **Symbol Length # 1** form a range into which the length of the symbol must fall to be considered valid.

### G-9-5 Guard Bar Status (Interleaved 2 of 5)

- **Note:** Whenever **Guard Bar** is enabled, the presence of guard bars (also called “bearer bars”) is required for decoding to take place.

- Usage:** Useful when I-2/5 multisymbols are enabled to prevent false data output. This typically occurs with highly tilted or skewed symbols.
- Definition:** A guard bar is a heavy bar, at least twice the width of the wide bar, surrounding the printed I-2/5 symbol and helping to prevent false reads.
- Serial Cmd:** <K472,status,check character status,check character output,symbol length #1,symbol length #2,guard bar status,range mode status>
- Default:** Disabled
- Options:** 0 = Disabled                      1 = Enabled

### G-9-6 Range Mode Status (Interleaved 2 of 5)

- Usage:** Useful in applications where I 2/5 symbols of a specific length are required.
- Definition:** When **Range Mode** is disabled, the reader checks the value of the symbol length against the values set in **Symbol Length # 1** and **Symbol Length # 2**. If the symbol length does not match either of the preset values, then it is rejected as invalid.
- When **Range Mode** is enabled, **Symbol Length # 1** and **Symbol Length # 2** are combined to form a range of valid symbol lengths. Any symbol length that does not fall into this range is rejected as an invalid symbol. Either of the preset symbol length values in the **Symbol Length # 1** and **Symbol Length # 2** fields can form the start or end of the range.
- Serial Cmd:** <K472,status,check character status,check character output,symbol length #1,symbol length #2,guard bar status,range mode status>
- Default:** Enabled
- Options:** 0 = Disabled                      1 = Enabled

## G-10 Code 93

<i>Usage:</i>	Sometimes used in clinical applications.
<i>Definition:</i>	Code 93 is a variable-length, continuous symbology employing four element widths. Each Code 93 character has nine modules that may be either black or white. Each character contains three bars and three spaces.
<i>Serial Cmd:</i>	< <b>K475</b> , <i>status</i> , <i>fixed symbol length status</i> , <i>symbol length</i> >
<i>Default:</i>	<b>Enabled</b>
<i>Options:</i>	<b>0 = Disabled</b> 1 = Enabled

### G-10-1 Fixed Symbol Length Status (Code 93)

<i>Definition:</i>	When disabled, the reader will accept any Code 93 symbol provided is doesn't exceed the system's maximum capabilities. When enabled, the reader will reject any Code 93 symbol that doesn't match the fixed symbol length.
<i>Serial Cmd:</i>	< <b>K475</b> , <i>status</i> , <b>fixed symbol length status</b> , <i>symbol length</i> >
<i>Default:</i>	<b>Disabled</b>
<i>Options:</i>	<b>0 = Disabled</b> 1 = Enabled

### G-10-2 Symbol Length (Code 93)

<i>Definition:</i>	This is the symbol length value against which all Code 93 symbols will be compared.
<i>Serial Cmd:</i>	< <b>K475</b> , <i>status</i> , <i>fixed symbol length status</i> , <b>symbol length</b> >
<i>Default:</i>	<b>10</b>
<i>Options:</i>	1 to 64

# G-11 Codabar

<b>Usage:</b>	Used in photo-finishing and library applications. Previously used in medical applications, but not typically used in newer medical applications.	
<b>Definition:</b>	Codabar is a 16-bit character set (0 through 9, and the characters \$, :, /, ., +, and -) with start/stop codes and at least two distinctly different bar widths.	
<b>Serial Cmd:</b>	< <b>K471,status,start/stop match,start/stop output,large intercharacter gap,fixed symbol length status,symbol length,check character type,check character output</b> >	
<b>Default:</b>	<b>Disabled</b>	
<b>Options:</b>	<b>0 = Disabled</b>	<b>1 = Enabled</b>

## G-11-1 Start/Stop Match (Codabar)

<b>Definition:</b>	When disabled, the reader will decode Codabar symbols whether or not the start and stop characters are the same. When enabled, the reader will not decode Codabar symbols unless the start and stop characters are the same.	
<b>Serial Cmd:</b>	< <b>K471,status,start/stop match,start/stop output,large intercharacter gap,fixed symbol length status,symbol length,check character type,check character output</b> >	
<b>Default:</b>	<b>Enabled</b>	
<b>Options:</b>	<b>0 = Disabled</b>	<b>1 = Enabled</b>

## G-11-2 Start/Stop Output (Codabar)

<b>Definition:</b>	When disabled, the start and stop characters will <i>not</i> be present in the data output of the decoded symbol. When enabled, the start and stop characters <i>will</i> be present in the data output of the decoded symbol. <b>Note:</b> Because the start and stop characters are included as part of the data, the characters must be included as part of the length in a fixed length mode of operation.	
<b>Serial Cmd:</b>	< <b>K471,status,start/stop match,start/stop output,large intercharacter gap,fixed symbol length status,symbol length,check character type,check character output</b> >	
<b>Default:</b>	<b>Enabled</b>	
<b>Options:</b>	<b>0 = Disabled</b>	<b>1 = Enabled</b>

## G-11-3 Large intercharacter Gap (Codabar)

<b>Definition:</b>	When disabled, the spaces between characters, or the “intercharacter gap”, are ignored during the decode process. <b>Note:</b> If the intercharacter space is large enough to be considered a margin, the symbol will not decode, regardless of this parameter’s setting.	
<b>Serial Cmd:</b>	< <b>K471,status,start/stop match,start/stop output,large intercharacter gap,fixed symbol length status,symbol length,check character type,check character output</b> >	
<b>Default:</b>	<b>Disabled</b>	
<b>Options:</b>	<b>0 = Disabled</b>	<b>1 = Enabled</b>



## G-11-4 Fixed Symbol Length Status (Codabar)

- Definition:** When disabled, the reader will accept any Codabar symbol provided it doesn't exceed the system's maximum capabilities.  
When enabled, the reader will reject any Codabar symbol that doesn't match the fixed length.
- Serial Cmd:** <**K471**,status,start/stop match,start/stop output,large intercharacter gap,**fixed symbol length status**,symbol length,check character type,check character output>
- Default:** **Enabled**
- Options:** **0 = Disabled**                      1 = Enabled

## G-11-5 Symbol Length (Codabar)

- Definition:** This is the value against which all Codabar symbol lengths will be compared.
- Serial Cmd:** <**K471**,status,start/stop match,start/stop output,large intercharacter gap,**fixed symbol length status**,**symbol length**,check character type,check character output>
- Default:** **10**
- Options:** 1 to 64

## G-11-6 Check Character Type (Codabar)

- Definition:** When disabled, the reader will not perform any character checking calculations on decoded Codabar symbols.  
When set to **Mod 16**, the reader will perform a modulus 16 check character calculation on the symbol. If the symbol does not pass this calculation, it will not be decoded.  
When set to **NW7**, The reader will perform an NW7 modulus 11 check character calculation on the symbol. If the symbol does not pass this calculation, it will not be decoded.  
When set to **Both**, the reader will perform both the Mod 16 and NW7 modulus 11 check character calculations on the symbol. If the symbol does not pass either calculation, it will not be decoded.
- Serial Cmd:** <**K471**,status,start/stop match,start/stop output,large intercharacter gap,**fixed symbol length status**,symbol length,**check character type**,check character output>
- Default:** **Disabled**
- Options:** **0 = Disabled**                      1 = Mod 16                      2 = NW7 (Mod 11)  
3 = Mod 16 and NW7

## G-11-7 Check Character Output (Codabar)

- Definition:** When this field is disabled and a check character calculation is enabled, the reader will strip the verified check character from the symbol data output. This condition must be accounted for if a fixed length is also being used.  
When enabled, the reader will output the check character as part of the symbol data. This condition must be accounted for if a fixed length is also being used.
- Serial Cmd:** <**K471**,status,start/stop match,start/stop output,large intercharacter gap,**fixed symbol length status**,symbol length,check character type,**check character output**>
- Default:** **Disabled**
- Options:** **0 = Disabled**                      1 = Enabled

## G-12 UPC/EAN

<i>Usage:</i>	Used primarily in point-of-sale applications in the retail industry. It is commonly used with the readers in applications in combination with <b>Matchcode</b> when there is a need to verify that the right product is being placed in the right packaging.	
<i>Definition:</i>	<b>UPC</b> (Universal Product Code) is a fixed length, numeric, continuous symbology. UPC can have two- or five-digit supplemental bar code data following the normal code. The UPC Version A (UPC, A) symbol is used to encode a 12 digit number. The first digit is the number system character, the next five are the manufacturer number, the next five are the product number, and the last digit is the checksum character. When enabled, the reader will read UPC Version A and UPC Version E only.	
<i>Serial Cmd:</i>	< <b>K473</b> , <b>UPC status</b> , <b>EAN status</b> , <b>supplementals status</b> , <b>separator status</b> , <b>separator character</b> , <b>supplemental type</b> , <b>format UPC-E as UPC-A</b> >	
<i>Default:</i>	<b>Enabled</b>	
<i>Options:</i>	0 = Disabled	<b>1 = Enabled</b>

### G-12-1 EAN Status

<i>Usage:</i>	<b>EAN</b> is the European version of the UPC symbology and is used in European market applications. <b>Note:</b> <b>UPC</b> must be enabled for <b>EAN</b> to take effect.	
<i>Definition:</i>	EAN is a subset of UPC. When enabled, the reader will read UPC Version A, UPC Version E, EAN 13, and EAN 8. It also appends a leading zero to UPC Version A symbol information and transmits 13 digits. If transmitting 13 digits when reading UPC Version A symbols is not desired, disable EAN. <b>Note:</b> The extra character identifies the country of origin.	
<i>Serial Cmd:</i>	< <b>K473</b> , <b>UPC status</b> , <b>EAN status</b> , <b>supplementals status</b> , <b>separator status</b> , <b>separator character</b> , <b>supplemental type</b> , <b>format UPC-E as UPC-A</b> >	
<i>Default:</i>	<b>Enabled</b>	
<i>Options:</i>	0 = Disabled	<b>1 = Enabled</b>

### G-12-2 Supplemental Status (UPC/EAN)

<i>Usage:</i>	Reads <b>Supplementals</b> typically used in publications and documentation.		
<i>Definition:</i>	A supplemental is a 2 to 5 digit symbol appended to the main symbol. When set to <b>Enabled</b> or <b>Required</b> , the reader reads supplemental code data that has been appended to the standard UPC or EAN codes.		
<i>Serial Cmd:</i>	< <b>K473</b> , <b>UPC status</b> , <b>EAN status</b> , <b>supplementals status</b> , <b>separator status</b> , <b>separator character</b> , <b>supplemental type</b> , <b>format UPC-E as UPC-A</b> >		
<i>Default:</i>	<b>Disabled</b>		
<i>Options:</i>	<b>0 = Disabled</b>	1 = Enabled	2 = Required

#### Disabled

UPC **Supplementals** will not be decoded.

#### Enabled

When enabled, the reader will try to decode a main and a supplemental.

## Required

When set to **Required**, both the main and the supplemental symbols must be read.

For example, if **Supplementals** is set to **Required**, **Separator** is enabled, and an asterisk is defined as the UPC separator character. Then the data is displayed as:

MAIN \* SUPPLEMENTAL.

- **Note:** Under no circumstances will the supplemental symbol data be sent without a main symbol.
- **Note:** If additional symbols—other than the main or supplemental—will be read in the same read cycle, **Number of Symbols** should be set accordingly.

### G-12-3 Separator Status (UPC/EAN)

<i>Usage:</i>	Allows users to distinguish between the main and <b>Supplemental</b> symbols.
<i>Definition:</i>	A character can be inserted between the standard UPC or EAN symbology and the supplemental symbology when <b>Supplementals</b> is set to <b>Enabled</b> or <b>Required</b> .
<i>Serial Cmd:</i>	< <b>K473</b> ,UPC status,EAN status,supplementals status, <b>separator status</b> , separator character,supplemental type,format UPC-E as UPC-A>
<i>Default:</i>	<b>Disabled</b>
<i>Options:</i>	<b>0 = Disabled</b> 1 = Enabled

### G-12-4 Separator Character (UPC/EAN)

<i>Usage:</i>	As required by the application.
<i>Definition:</i>	Allows the user to change the separator character from a comma to a new character.
<i>Serial Cmd:</i>	< <b>K473</b> ,UPC status,EAN status,supplementals status, <b>separator status</b> , <b>separator character</b> ,supplemental type,format UPC-E as UPC-A>
<i>Default:</i>	, ( <b>comma</b> )
<i>Options:</i>	Any ASCII character.

- **Note:** Whenever **Separator Character** is defined as a comma ( , ) sending a <**K473,s?**> command will return the current settings, including the separator character comma which appears after the separator status comma.

### G-12-5 Supplemental Type (UPC/EAN)

<i>Usage:</i>	As required by symbology used in application.
<i>Definition:</i>	Allows the user to select 2 character or 5 character supplements, or both.
<i>Serial Cmd:</i>	< <b>K473</b> ,UPC status,EAN status,supplementals status, <b>separator status</b> , separator character, <b>supplemental type</b> ,format UPC-E as UPC-A>
<i>Default:</i>	<b>Both</b>
<i>Options:</i>	<b>0 = Both</b> 1 = 2 characters only                      2 = 5 characters only

## Both

Either 2 character or 5 character supplementals will be considered valid.

## 2 Characters Only

Only two character supplementals will be considered valid.

## 5 Characters Only

Only five character supplementals will be considered valid.

## G-12-6 Format UPC-E as UPC-A (UPC/EAN)

- Definition:* When disabled, the reader will output the version E symbols in their encoded 6-character format.  
When enabled, the reader will format the symbol as either a 12-character UPC-A symbol or an EAN-13 symbol, depending on the state of the EAN status parameter. This formatting reverses the zero suppression that is used to generate the symbol in the UPC specification.
- Serial Cmd:* <**K473**,*UPC status,EAN status, supplementals status, separator status, separator character, supplemental type, **format UPC-E as UPC-A***>
- Default:* **Enabled**
- Options:* **0 = Disabled**                      1 = Enabled

## G-13 Pharmacode

<i>Usage:</i>	Used mostly with packaging for the pharmaceuticals industry.	
<i>Definition:</i>	Encodes up to five different numbers, each with its own color, which may be entered in decimal or "binary" format with a 1 represented by a thick bar and a 0 represented by a thin bar. Bar width is independent of height. In decimal format, each part can be up to 999,999. In binary format, each input can have up to 19 ones and zeros. <b>Important:</b> When Pharmacode is enabled, other linear symbologies will not decode properly. Disable Pharmacode before reading other linear symbologies.	
<i>Serial Cmd:</i>	< <b>K477</b> , <i>status</i> , <i>fixed symbol length status</i> , <i>fixed symbol length</i> , <i>minimum number of bars</i> , <i>bar width status</i> , <i>direction</i> , <i>fixed threshold value</i> , <i>background color</i> >	
<i>Default:</i>	<b>Disabled</b>	
<i>Options:</i>	<b>0 = Disabled</b>	1 = Enabled

### G-13-1 Fixed Symbol Length Status (Pharmacode)

<i>Definition:</i>	When enabled, the reader will check the symbol length against the symbol length field. If disabled, any length will be considered valid.	
<i>Serial Cmd:</i>	< <b>K477</b> , <i>status</i> , <b>fixed symbol length status</b> , <i>fixed symbol length</i> , <i>minimum number of bars</i> , <i>bar width status</i> , <i>direction</i> , <i>fixed threshold value</i> , <i>background color</i> >	
<i>Default:</i>	<b>Disabled</b>	
<i>Options:</i>	<b>0 = Disabled</b>	1 = Enabled

### G-13-2 Fixed Symbol Length (Pharmacode)

<i>Definition:</i>	Specifies the exact number of bars that must be present for the reader to recognize and decode the Pharmacode symbol.	
<i>Serial Cmd:</i>	< <b>K477</b> , <i>status</i> , <i>fixed symbol length status</i> , <b>fixed symbol length</b> , <i>minimum number of bars</i> , <i>bar width status</i> , <i>direction</i> , <i>fixed threshold value</i> , <i>background color</i> >	
<i>Default:</i>	<b>5</b>	
<i>Options:</i>	1 to 16	

### G-13-3 Minimum Number of Bars (Pharmacode)

<i>Definition:</i>	Sets the minimum number of bars that a Pharmacode symbol must have to be considered valid.	
<i>Serial Cmd:</i>	< <b>K477</b> , <i>status</i> , <i>fixed symbol length status</i> , <i>fixed symbol length</i> , <b>minimum number of bars</b> , <i>bar width status</i> , <i>direction</i> , <i>fixed threshold value</i> , <i>background color</i> >	
<i>Default:</i>	<b>4</b>	
<i>Options:</i>	1 to 16	

### G-13-4 Bar Width Status (Pharmacode)

**Definition:** If set to **Mixed**, the reader will autodiscriminate between narrow bars and wide bars. If set to **All Narrow**, all bars will be considered as narrow bars. If set to **All Wide**, all bars will be considered as wide bars. If set to **Fixed Threshold**, it will use the fixed threshold value to determine whether the bars are narrow or wide. The **Bar Width Status** setting will be ignored when the reader is able to tell the difference between the narrow and the wide bars.

**Serial Cmd:** <K477,status,fixed symbol length status,fixed symbol length,minimum number of bars,bar width status,direction,fixed threshold value,background color>

**Default:** **Mixed**

**Options:** **0 = Mixed**  
 1 = All Narrow  
 2 = All Wide  
 3 = Fixed Threshold

### G-13-5 Direction (Pharmacode)

**Definition:** Specifies the direction in which a symbol can be read.

**Serial Cmd:** <K477,status,fixed symbol length status,fixed symbol length,minimum number of bars,bar width status,direction,fixed threshold value,background color>

**Default:** **Forward**

**Options:** **0 = Forward**                      1 = Reverse

### G-13-6 Fixed Threshold Value (Pharmacode)

**Definition:** Used when **Bar Width Status** is set to **Fixed Threshold**. Defines the minimum difference in pixels that will distinguish a narrow bar from a wide bar.

**Serial Cmd:** <K477,status,fixed symbol length status,fixed symbol length,minimum number of bars,bar width status,direction,fixed threshold value,background color>

**Default:** **10**

**Options:** 1 to 65535

### G-13-7 Background Color (Pharmacode)

**Definition:** Used when the color of bars is reversed. Sets the background color that a Pharmacode symbol must have to be considered valid.

**Serial Cmd:** <K477,status,fixed symbol length status,fixed symbol length,minimum number of bars,bar width status,direction,fixed threshold value,background color>

**Default:** **White**

**Options:** 0 = Black                      1 = White

# G-14 Postal Symbologies

**Important: Postal Symbologies** must have a minimum pixels-per-element value of **4** to be decoded reliably by the reader.

The reader must be configured to specific read range, field of view, and camera parameters before decoding Postal Symbologies.

For optimal decode results, position the symbol as close to the center of the reader's field of view as possible.

## G-14-1 Postal Symbology Type

<i>Usage:</i>	The following 1D <b>Postal Symbologies</b> are used in mail sortation, auditing, certified mail, registered mail, metered mail, and point-of-sale (POS) applications.
<i>Definition:</i>	Determines the postal symbology that will be decoded by the reader.
<i>Serial Cmd:</i>	< <b>K460</b> , <i>postal symbology type</i> , <i>POSTNET status</i> , <i>PLANET status</i> , <i>USPS4CB status</i> >
<i>Default:</i>	<b>Disabled</b>
<i>Options:</i>	<b>0 = Disabled</b> 1 = U.S. Post (POSTNET, PLANET, USPS4CB) 2 = Australia Post 3 = Japan Post 4 = Royal Mail 5 = KIX 6 = UPU

### U.S. Post (POSTNET, PLANET, USPS4CB)

When **U.S. Post** is enabled (<**K460**,1>), the reader will only decode **POSTNET**, **PLANET**, and **USPS4CB** symbols.

**Important: POSTNET Status**, **PLANET Status**, and **USPS4CB Status** are enabled by default. However, if any of the three U.S. Post symbologies is set to **disabled** individually, symbols of that type will not be decoded by the reader even when U.S. Post is enabled.

For example, if **U.S. Post** is enabled but **POSTNET Status** is disabled (<**K460**,1,0>), **POSTNET** symbols will not be decoded by the reader.

See **POSTNET Status**, **PLANET Status**, and **GS1 DataBar** for more detail about U.S. Post symbologies.

### Australian Post

When **Australia Post** is enabled (<**K460**,2>), the reader will only decode Australia Post symbols.

### Japan Post

When **Japan Post** is enabled (<**K460**,3>), the reader will only decode Japan Post symbols.

### Royal Mail

When **Royal Mail** is enabled (<**K460**,4>), the reader will only decode Royal Mail symbols.

## KIX

When **KIX** is enabled (<**K460,5**>), the reader will only decode KIX symbols.

## UPU

When **UPU** is enabled, the reader will decode UPU symbols.

For example, if **Postal Symbology Type** is set to **UPU** and **POSTNET Status** is enabled and (<**K460,6,1**>), the reader will attempt to decode both UPU and POSTNET symbols.

### G-14-2 POSTNET Status

- Usage:* **POSTNET** is used by the United States Postal Service to direct mail. The ZIP Code or ZIP+4 Code is encoded in the symbol. Data is encoded in half-height and full-height bars, making POSTNET a “2-state” symbology. The delivery point (usually the last two digits of the address or post office box number) is also typically encoded in POSTNET symbols.
- Definition:* If **U.S. Post** and **POSTNET Status** are both enabled, the reader will decode POSTNET symbols.
- Serial Cmd:* <**K460,postal symbology type,POSTNET status,PLANET status,USPS4CB status**>
- Default:* **Enabled**
- Options:* 0 = Disabled  
1 = **Enabled**

### G-14-3 PLANET Status

- Usage:* **PLANET (Postal Alphanumeric Encoding Technique)** is a symbology used by the United States Postal Service to track and identify items during delivery. Each PLANET symbol is either 12 or 14 digits long, and encodes data in half-height and full-height bars, making PLANET a “2-state” symbology. The symbol always starts and ends with a full-height bar, or “guard rail”, and each individual digit is represented by a set of five bars in which two of the bars are always short.
- Definition:* If **U.S. Post** and **PLANET Status** are both enabled, the reader will decode PLANET symbols.
- Serial Cmd:* <**K460,postal symbology type,POSTNET status,PLANET status,USPS4CB status**>
- Default:* **Enabled**
- Options:* 0 = Disabled  
1 = **Enabled**



## G-14-4 USPS4CB Status

- Usage:* **USPS4CB**, also called **Intelligent Mail**, is used by the United States Postal Service to sort and track individual items as well as flats of mail. USPS4CB combines the capabilities of POSTNET and PLANET, and can encode 31 digits (65 bars). USPS4CB symbols are slightly longer than POSTNET symbols, and offer additional flexibility in choosing symbol height and width. Data is encoded in four types of bars (“states”), each of which is identified by a name and a value. This type of postal symbol is known as “4-state”. Each bar has a “tracker”, or middle section, to which an “ascender” (top section) or “descender” (bottom section) may be added. The 4-state format allows the symbol to contain more information, and makes it easier to decode. 4-state symbols can also be printed easily in a variety of media, including dot matrix, inkjet, and laser.
- Definition:* If **U.S. Post** and **USPS4CB Status** are both enabled, the reader will decode USPS4CB symbols.
- Serial Cmd:* <**K460**,postal symbology type,POSTNET status,PLANET status,**USPS4CB status**>
- Default:* **Enabled**
- Options:* 0 = Disabled  
**1 = Enabled**

# G-15 GS1 DataBar

## G-15-1 DataBar Expanded

- Usage:* Used to encode primary and supplementary data in retail point-of-sale and other applications.
- Definition:* DataBar Expanded is a variable length symbology that can encode supplementary information in addition to the 14-digit EAN item identification number and is capable of encoding up to 74 numeric or 41 alphabetic characters.
- Serial Cmd:* <**K484,status,fixed symbol length status,fixed symbol length**>
- Default:* **Enabled**
- Options:* **0 = Disabled**      1 = Enabled

## G-15-2 Fixed Symbol Length Status (DataBar Expanded)

- Definition:* When enabled, the reader will check the symbol length against the symbol length field, minus the embedded check character. If disabled, any length would be considered valid.
- Serial Cmd:* <**K484,status,fixed symbol length status,fixed symbol length**>
- Default:* **Disabled**
- Options:* **0 = Disabled**      1 = Enabled

## G-15-3 Fixed Symbol Length (DataBar Expanded)

- Usage:* **Fixed Symbol Length** helps prevent truncations and increases data integrity by ensuring that only one symbol length will be accepted.
- Definition:* Specifies the exact number of characters that the reader will recognize (this does not include start, stop, and check character characters). The reader ignores any symbol not having the specified length.
- Serial Cmd:* <**K484,status,fixed symbol length status,fixed symbol length**>
- Default:* **14**
- Options:* 1 to 74

## G-15-4 DataBar Limited

- Usage:* DataBar Limited is designed to be read by laser and CCD readers. It is not recommended for omnidirectional slot scanners.
- Definition:* Encodes a smaller 14-digit symbol (74 modules wide) that is not omnidirectional.
- Serial Cmd:* <**K483,status**>
- Default:* **Enabled**
- Options:* **0 = Disabled**      1 = Enabled

## G-15-5 DataBar-14

- Usage:* Used in the grocery, retail, and prescription drug industries where 14-digit EAN item identification may be needed.
- Definition:* DataBar-14 is a fixed symbol length symbology that encodes 14 digits, including a 1-digit indicator. DataBar-14 is 96 modules wide. It can be stacked in two rows, it can read omnidirectionally if printed in full height, or horizontally if height-truncated for small marking.
- Serial Cmd:* <**K482,status**>
- Default:* **Enabled**
- Options:* **0 = Disabled**      1 = Enabled

# G-16 PDF417

<i>Usage:</i>	Used in applications where a large amount of information (over 32 characters) needs to be encoded within a symbol, typically where the symbol is transported from one facility to another. For example, an automobile assembly line might use a single symbol with multiple fields of information that will be read at several stations along the way, without reference to a database.	
<i>Definition:</i>	A two-dimensional, multi-row (3 to 90), continuous, variable length symbology that has high data capacity for storing up to 2,700 numeric characters, 1,800 printable ASCII characters, or 1,100 binary characters per symbol. Each symbol character consists of 4 bars and 4 spaces in a 17-module structure.	
<i>Serial Cmd:</i>	< <b>K476</b> , <i>status</i> ,[ <i>unused</i> ], <i>fixed symbol length status</i> , <i>fixed symbol length</i> >	
<i>Default:</i>	<b>Enabled</b>	
<i>Options:</i>	0 = Disabled	1 = <b>Enabled</b>

**Note:** Sending <a1> will cause PDF417 data to be prefaced with information consisting of error correction level (ECC Level *n*), number of rows (*n* Rows), number of columns (*n* Columns), number of informative code words (*n* Info Code Words) and the number of data characters (*n* Data Characters). This feature can be disabled by re-sending <a1>.

## G-16-1 Fixed Symbol Length Status (PDF417)

<i>Serial Cmd:</i>	< <b>K476</b> , <i>status</i> ,[ <i>unused</i> ], <i>fixed symbol length status</i> , <i>fixed symbol length</i> >	
<i>Default:</i>	<b>Disabled</b>	
<i>Options:</i>	0 = <b>Disabled</b>	1 = Enabled

## G-16-2 Fixed Symbol Length (PDF417)

<i>Usage:</i>	Used to increase data integrity by ensuring that only one symbol length will be accepted.	
<i>Definition:</i>	When enabled, the PDF symbol must contain the same number of characters as the symbol length setting before it can be considered a good read. The reader will ignore any symbol not having the specified length.	
<i>Serial Cmd:</i>	< <b>K476</b> , <i>status</i> ,[ <i>unused</i> ], <i>fixed symbol length status</i> , <i>fixed symbol length</i> >	
<i>Default:</i>	<b>10</b>	
<i>Options:</i>	1 to 2710	

**Note:** Fixed Symbol Length Status must be enabled for Fixed Symbol Length to take effect.

# G-17 MicroPDF417

*Usage:* Used for labelling small items that need large data capacity.

*Definition:* A variant of PDF417, a very efficient and compact stacked symbology that can encode up to 250 alphanumeric characters or 366 numeric characters per symbol.

*Serial Cmd:* <**K485,status,[unused],fixed symbol length status,fixed symbol length**>

*Default:* **Enabled**

*Options:* **0 = Disabled**      1 = Enabled

## G-17-1 Fixed Symbol Length Status (MicroPDF417)

*Serial Cmd:* <**K485,status,[unused],fixed symbol length status,fixed symbol length**>

*Default:* **Disabled**

*Options:* **0 = Disabled**      1 = Enabled

## G-17-2 Fixed Symbol Length (MicroPDF417)

*Usage:* Used to increase data integrity by ensuring that only one symbol length will be accepted.

*Definition:* When enabled, the MicroPDF417 symbol must contain the same number of characters as the symbol length setting before it can be considered a good read. The reader will ignore any symbol not having the specified length.

*Serial Cmd:* <**K485,status,[unused],fixed symbol length status,fixed symbol length**>

*Default:* **10**

*Options:* 1 to 366

**Note:** **Fixed Symbol Length Status** must be enabled for **Fixed Symbol Length** to take effect.

# G-18 Composite

When set to **Enabled** or **Required**, will decode the 2D composite component of a linear symbol. The linear symbol can be DataBar-14, DataBar Expanded, DataBar Limited, EAN-128, UPC-A, EAN-13, EAN-8, and UPC-E.

<i>Usage:</i>	Allows reading by both linear and 2D readers.		
<i>Definition:</i>	Combines 2D and linear width-modulated symbology on the same symbol where different messages can be read by each reader type.		
<i>Serial Cmd:</i>	< <b>K453</b> ,mode,separator status,separator>		
<i>Default:</i>	<b>Disabled</b>		
<i>Options:</i>	<b>0 = Disabled</b>	1 = Enabled	2 = Required

## Enabled

If **Composite** is set to **Enabled**, the reader will decode both the 2D composite and linear components. However, if the 2D composite component is not decoded, the linear data will be sent by itself at the end of the read cycle.

## Required

If set to **Required**, the reader must decode both components, or a No-Read will occur.

### G-18-1 Separator Status (Composite)

<i>Usage:</i>	Allows the user to distinguish between the main and <b>Supplemental</b> symbols.		
<i>Definition:</i>	Separates the linear and the composite component.		
<i>Serial Cmd:</i>	< <b>K453</b> ,mode,separator status,separator>		
<i>Default:</i>	<b>Disabled</b>		
<i>Options:</i>	<b>0 = Disabled</b>	1 = Enabled	

### G-18-2 Separator Character (Composite)

**Note:** The Separator Character will be the same as the character defined in the **Multisymbol Separator** field of the <**K222**> command.

<i>Usage:</i>	As required by the application.		
<i>Definition:</i>	Allows the user to change the separator character from a comma to a new character.		
<i>Serial Cmd:</i>	< <b>K453</b> ,mode,separator status,separator>		
<i>Default:</i>	, (comma)		
<i>Options:</i>	Any ASCII character.		

# G-19 DotCode

**Important:** When DotCode is enabled, no other symbologies will be decodable. You must disable DotCode to decode symbols of any other type.

See [DotCode](#) in [Advanced Settings](#) for details about how to specify row and column dimensions of DotCode symbols.

## G-19-1 DotCode Status

*Serial Cmd:* <K497,status,rotation mode>

*Default:* **0 = Disabled**

*Options:* **0 = Disabled**

1 = Enabled

### Disabled

The reader will not attempt to decode DotCode symbols.

### Enabled

The reader will attempt to decode DotCode symbols.

## G-19-2 Rotation Mode

*Serial Cmd:* <K497,status,rotation mode>

*Default:* **0 = No Rotation**

*Options:* **0 = No Rotation**

1 = Low Rotation

2 = Omnidirectional

### No Rotation

The reader will decode horizontal and vertical symbols (**+/- approximately 3 degrees**).

### Low Rotation

The reader will decode **+/- approximately 10 degrees** from the horizontal or vertical symbols. It is slightly slower than the No Rotation option.

### Omnidirectional

The reader supports **360 degree** decoding. It is significantly slower than the other two options.



# I/O Parameters

This section includes instructions on setting up conditions for changing input/output electrical transitions for control of the reader's internal and external devices. A discrete I/O (in/out) signal is an electrical transition from one voltage level to another so that digital switching can occur.

---

H-1	I/O Parameters Serial Commands	H-2
H-2	Symbol Data Output	H-5
H-3	No-Read Message	H-7
H-4	Read Duration Output	H-8
H-5	Output Indicators	H-9
H-6	LED Configuration	H-11
H-7	Serial Verification	H-12
H-8	Setup Button	H-13
H-9	Setup Button Modes	H-15
H-10	Configurable Output 1	H-17
H-11	Trend Analysis Output 1	H-19
H-12	ISO/IEC 16022 Symbol Quality Output 1	H-21
H-13	ISO/IEC 15415 Symbol Quality Output 1	H-23
H-14	ISO/IEC 15416 Symbol Quality Output 1	H-28
H-15	ISO/IEC 29158 Symbol Quality Output 1	H-34
H-16	Diagnostics Output 1	H-38
H-17	Other Outputs	H-39
H-18	Power On/Reset Counts	H-43
H-19	Time Since Reset	H-44
H-20	Service Message	H-45
H-21	User-Assigned Name	H-46
H-22	Output Object Info	H-47
H-23	Database Identifier Output	H-48
H-24	Quality Output	H-49
H-25	Image Push to Host	H-50
H-26	Image Push to Host Detailed Setup	H-52



# H-1 I/O Parameters Serial Commands

Power On/Reset Counts	<K406,power-on,resets,power-on saves,customer default saves>
Time Since Reset (Read-Only)	<K407,hours,minutes>
Service Message	<K409,status,service message,threshold,resolution>
User-Defined Name	<K412,user-defined name>
Serial Verification	<K701,serial command echo status,control/hex output>
Quality Output	<K704,quality output separator,decodes per trigger status>
Symbol Data Output	<K705,status,when to output,symbology identifier status>
Read Duration Output	<K706,status,separator>
No-Read Message	<K714,status,message>
Output Object Info	<K734,output frame number status,output coordinates status>
LED Configuration	<K737,ISO/IEC 16022 grade>
Output Indicators	<K750,green flash LED status,target pattern LED status,green flash duration>
Database Identifier Output	<K759,status,separator character>
Image Push to Host	<K764,Image Storage Status,Stored Image Type,Image Storage, Image File Format,Image Quality,Image Scale,File Save Options>
Image Push to Host Detail Setup	<K763,Image Storage Location,FTP Host Info,Transfer Optimization, RAM Drive Size in MB,Save Image Until,Action at Image Storage Limit>
Setup Button	<K770,global status,default on power-on,load configuration database, save for power-on>
Setup Button Modes	<K771,button option 1,button option 2,button option 3,button option 4>
Trend Analysis Output 1	<K780,trend analysis mode,number of triggers,number to output on,decodes per trigger>
Trend Analysis Output 2	<K781,trend analysis mode,number of triggers,number to output on,decodes per trigger>
Trend Analysis Output 3	<K782,trend analysis mode,number of triggers,number to output on,decodes per trigger>
Diagnostic Output 1	<K790,service unit message status>
Diagnostic Output 2	<K791,service unit message status>
Diagnostic Output 3	<K792,service unit message status>
ISO/IEC 16022 Symbol Quality Output 1	<K800,output on symbol contrast,symbol contrast threshold,output on print growth,print growth threshold,output on axial non-uniformity, axial non-uniformity threshold,output on Unused ECC,Unused ECC threshold>
ISO/IEC 16022 Symbol Quality Output 2	<K801,output on symbol contrast,symbol contrast threshold,output on print growth,print growth threshold,output on axial non-uniformity, axial non-uniformity threshold,output on Unused ECC,Unused ECC threshold>
ISO/IEC 16022 Symbol Quality Output 3	<K802,output on symbol contrast,symbol contrast threshold,output on print growth,print growth threshold,output on axial non-uniformity, axial non-uniformity threshold,output on Unused ECC,Unused ECC threshold>
Output 1 Parameters	<K810,output on,output state,pulse width,output mode>
Output 2 Parameters	<K811,output on,output state,pulse width,output mode>
Output 3 Parameters	<K812,output on,output state,pulse width,output mode>



ISO/IEC 15415 Symbol Quality Output 1	< <b>K870</b> , Output on Overall Grade, Overall Grade Threshold, Symbol Contrast, Symbol Contrast Threshold, Modulation, Modulation Threshold, Reflectance Margin, Reflectance Margin Threshold, Fixed Pattern Damage, Fixed Pattern Damage Threshold, Axial Nonuniformity, Axial Nonuniformity Threshold, Grid Nonuniformity, Grid Nonuniformity Threshold, Unused ECC, Unused ECC Threshold>
ISO/IEC 15415 Symbol Quality Output 2	< <b>K871</b> , Output on Overall Grade, Overall Grade Threshold, Symbol Contrast, Symbol Contrast Threshold, Modulation, Modulation Threshold, Reflectance Margin, Reflectance Margin Threshold, Fixed Pattern Damage, Fixed Pattern Damage Threshold, Axial Nonuniformity, Axial Nonuniformity Threshold, Grid Nonuniformity, Grid Nonuniformity Threshold, Unused ECC, Unused ECC Threshold>
ISO/IEC 15415 Symbol Quality Output 3	< <b>K872</b> , Output on Overall Grade, Overall Grade Threshold, Symbol Contrast, Symbol Contrast Threshold, Modulation, Modulation Threshold, Reflectance Margin, Reflectance Margin Threshold, Fixed Pattern Damage, Fixed Pattern Damage Threshold, Axial Nonuniformity, Axial Nonuniformity Threshold, Grid Nonuniformity, Grid Nonuniformity Threshold, Unused ECC, Unused ECC Threshold>
ISO/IEC 15416 Symbol Quality Output 1	< <b>K880</b> , Output on Overall Grade, Overall Grade Threshold, Edge Determination, Edge Determination Threshold, Decode, Decode Threshold, Contrast, Contrast Threshold, Min Reflectance, Min Reflectance Threshold, Min Edge Contrast, Min Edge Contrast Threshold, Modulation, Modulation Threshold, Defects, Defects Threshold, Decodability, Decodability Threshold, Quiet Zone, Quiet Zone Threshold >
ISO/IEC 15416 Symbol Quality Output 2	< <b>K881</b> , Output on Overall Grade, Overall Grade Threshold, Edge Determination, Edge Determination Threshold, Decode, Decode Threshold, Contrast, Contrast Threshold, Min Reflectance, Min Reflectance Threshold, Min Edge Contrast, Min Edge Contrast Threshold, Modulation, Modulation Threshold, Defects, Defects Threshold, Decodability, Decodability Threshold, Quiet Zone, Quiet Zone Threshold >
ISO/IEC 15416 Symbol Quality Output 3	< <b>K882</b> , Output on Overall Grade, Overall Grade Threshold, Edge Determination, Edge Determination Threshold, Decode, Decode Threshold, Contrast, Contrast Threshold, Min Reflectance, Min Reflectance Threshold, Min Edge Contrast, Min Edge Contrast Threshold, Modulation, Modulation Threshold, Defects, Defects Threshold, Decodability, Decodability Threshold, Quiet Zone, Quiet Zone Threshold >
ISO/IEC 29158 Symbol Quality Output 1	< <b>K890</b> , Output on Overall Grade, Overall Grade Threshold, Cell Contrast, Cell Contrast Threshold, Cell Modulation, Cell Modulation Threshold, Fixed Pattern Damage, Fixed Pattern Damage Threshold, Axial Nonuniformity, Axial Nonuniformity Threshold, Grid Nonuniformity, Grid Nonuniformity Threshold, Unused ECC, Unused ECC Threshold>
ISO/IEC 29158 Symbol Quality Output 2	< <b>K891</b> , Output on Overall Grade, Overall Grade Threshold, Cell Contrast, Cell Contrast Threshold, Cell Modulation, Cell Modulation Threshold, Fixed Pattern Damage, Fixed Pattern Damage Threshold, Axial Nonuniformity, Axial Nonuniformity Threshold, Grid Nonuniformity, Grid Nonuniformity Threshold, Unused ECC, Unused ECC Threshold>



---

ISO/IEC 29158 Symbol Quality Output 3	<i>&lt;K892, Output on Overall Grade, Overall Grade Threshold, Cell Contrast, Cell Contrast Threshold, Cell Modulation, Cell Modulation Threshold, Fixed Pattern Damage, Fixed Pattern Damage Threshold, Axial Nonuniformity, Axial Nonuniformity Threshold, Grid Nonuniformity, Grid Nonuniformity Threshold, Unused ECC, Unused ECC Threshold&gt;</i>
---------------------------------------	---

# H-2 Symbol Data Output

## H-2-1 Symbol Data Output Status

- **Note:** **Symbol Data Output** relates to data and should not be confused with **Outputs 1, 2, and 3** listed in the **Output Parameters** which describe output states and functions.

Usage:	Useful when the host needs symbol data only under certain conditions.
Definition:	Defines the conditions under which decoded symbol data is transmitted to the host.
Serial Cmd:	<i>&lt;K705,symbol data output status,when to output,symbology identifier status&gt;</i>
Default:	Good Read
Options:	0 = Disabled 1 = Match 2 = Mismatch 3 = Any Good Read 4 = Only If All Good Reads

- **Note:** **Symbol Data Output Status**, if set to **Match** or **Mismatch**, will not take effect unless **Matchcode Type** is enabled and a master symbol is loaded into memory.

### Disabled

Usage:	It is useful when an application only needs to use the discrete outputs and can allow the reader to do the decision-making. When <b>Disabled</b> , the host does not need the symbol data and the communication lines are used only for setup and status checks.
Definition:	When set to <b>Disabled</b> , the reader will not transmit any data that is generated during a read cycle (symbols, No-Reads, etc.)

### Match

Usage:	<b>Match</b> is used in an application that requires specific symbol information and needs to sort, route, or verify based on matching the specific symbol data.
Definition:	When set to <b>Match</b> , the reader transmits symbol data whenever a symbol matches a master symbol. However, if <b>Matchcode Type</b> is <b>Disabled</b> , it transmits on any good read.

- **Note:** A No-Read can still be transmitted if **Enabled**.

### Mismatch

Usage:	Mismatch is typically used as a flag within the host system to prevent an item from being routed in the wrong container.
Definition:	With Mismatch enabled, the reader transmits symbol data whenever the symbol data information does NOT match the master symbol.

- **Note:** A No-Read can still be transmitted if **Enabled**.

### Any Good Read

Usage:	<b>Any Good Read</b> is used when an application requires all symbol data to be transmitted. It's typically used in tracking applications in which each object is uniquely identified.
Definition:	With <b>Any Good Read</b> enabled, the reader outputs symbol data for any qualified symbol in the read cycle regardless of <b>Matchcode Type</b> setting. <b>No Read</b> is output if no symbols are qualified.

## Only If All Good Reads

Definition: With **Only If All Good Reads** enabled, the reader outputs symbol data only when all symbols in the read cycle are qualified. **No Read** is output if no symbols are qualified.

### H-2-2 When to Output Symbol Data

Definition: This command allows the user to choose when symbol data can be sent to the host.

Serial Cmd: `<K705,symbol data output status,when to output,symbology identifier status>`

Default: As Soon As Possible

Options: 0 = ASAP                      1 = End of Read Cycle

## As Soon As Possible

Usage: As Soon As Possible is useful in applications in which symbol data needs to be moved quickly to the host, typically when the host is making decisions based on symbol data.

Definition: Enabling **As Soon As Possible** causes symbol data to be sent to the host immediately after a symbol has been successfully decoded.

- **Note:** More than one decode might in fact be required to qualify as a good read, depending on how **Decodes Before Output** is set.

## End of Read Cycle

Usage: **End of Read Cycle** is useful in timing-based systems in which the host is not ready to accept data at the time that it is decoded.

Definition: Enabling **End of Read Cycle** means that symbol data does not get sent to the host until the read cycle ends with a timeout or new trigger.

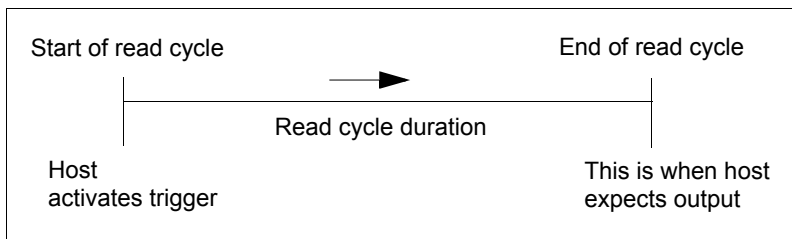

### H-2-3 Symbology Identifier Status

Serial Cmd: `<K705,symbol data output status,when to output,symbology identifier status>`

Default: Disabled

Options: 0 = Disabled                      1 = Enabled

## Disabled

When set to **Disabled**, the symbol data output does not contain symbology information.

## Enabled

When set to **Enabled**, the symbol data output contains a three-character symbology identifier sequence.

## H-3 No-Read Message

Usage:	Used in applications where the host needs serial verification that a symbol has not been read and especially useful in new print verification.
Definition:	When enabled, and if no symbol has been decoded before timeout or the end of the read cycle, the No-Read message will be transmitted to the host.

### H-3-1 No-Read Message Mode

Serial Cmd:	<K714, <i>No-Read message status</i> , <i>No-Read message</i> >	
Default:	Enabled	
Options:	0 = Disabled	1 = Enabled

#### Disabled

Only symbol data is output after a read cycle.

#### Enabled

When the reader is in a triggered mode, a No-Read message will be appended for each failed read attempt.

### H-3-2 No-Read Message

Definition:	Any combination of ASCII characters can be defined as the No-Read message.
Serial Cmd:	<K714, <i>No-Read message status</i> , <i>No-Read message</i> >
Default:	NOREAD
Options:	A string of up to 64 characters.

- **Note: No-Read Message** will only be transmitted if **Symbol Data Output** is set to **Match**, **Mismatch**, or **Good Read**. **No-Read Message** can be set to any ASCII character.

## H-4 Read Duration Output

- Usage: Useful in evaluating actual read cycle timing results, especially when initially setting up an application to determine maximum line speed (obtainable based on spacing between symbols.)
- Definition: When enabled the duration of the read cycle (in milliseconds) is appended to the symbol data.  
The read duration is the time from the beginning of the read cycle until data is output.

### H-4-1 Read Duration Output Mode

- Serial Cmd: <K706,*status*,*separator*>  
 Default: Disabled  
 Options: 0 = Disabled          1 = Enabled

- **Important:** To measure the entire read cycle when in **External Level** trigger mode, set **When to Output Symbol Data to End of Read Cycle**.

This output can measure over 49 days' worth of duration; if exceeded, the "OVERFLOW" message will be output in place of the duration.

### H-4-2 Read Duration Output Separator

- Definition: User defined character that separates the symbol information from the **Read Duration Output**.
- Serial Cmd: <K706,*status*,*separator*>  
 Default: [space character]  
 Options: Any ASCII character.

## H-5 Output Indicators

MicroHAWK readers have three LED arrays, as follows:

- 1** A target pattern of blue LEDs for centering the field of view, which is projected from the front of the reader.
- 2** An array of green LEDs projected from the front of the reader that can be programmed to flash in response to user-defined conditions.
- 3** A row of five status LEDs on the side of the reader.

### H-5-1 Green Flash Mode

Usage:	Used as a visual verification that a good read has occurred.
Definition:	An array of green LEDs in the front of the reader can be programmed to flash in response to user-defined conditions.
Serial Cmd:	<code>&lt;K750,green flash mode,target pattern status,green flash duration&gt;</code>
Default:	Static Presentation
Options:	0 = Disabled 1 = Good Read 2 = Static Presentation 3 = Match 4 = Mismatch 5 = Strobe

#### Disabled

Green flash LEDs are disabled.

#### Good Read

Green flash LEDs will flash when a good read condition is met or when **Matchcode** is enabled and a match occurs.

#### Static Presentation Mode

**Static Presentation Mode** is used in conjunction with **Continuous Read Mode**: `<K200,0>`.

When operating in **Static Presentation Mode**, the red LEDs will illuminate while the reader is searching for a symbol in **Continuous Read Mode**. When a symbol is placed in the field of view and a good read occurs, the green LEDs will illuminate and stay on for the duration of time set in **Green Flash Duration**. Only one read will occur during that time unless more than one symbol is enabled in **Number of Symbols**.

- **Note:** If **Static Presentation Mode** is selected but the reader is not in **Continuous Read**, the **Green Flash** will not occur.

To use Static Presentation:

- 1** Enable **Continuous Read**.
- 2** Select the number of symbols.
- 3** Enable **Static Presentation** in **Green Flash Mode**.
- 4** Select the read time in **Green Flash Duration**.

## Match

The green LEDs will flash when a match condition is met. If multisymbol is enabled, then green flash LEDs will illuminate only if all symbols qualify as a match. If matchcode is disabled, then this mode will activate the LEDs on a good read.

## Mismatch

Same as **Match**, except that LEDs will illuminate on a mismatch.

## Strobe

Green flash LEDs will act as an illumination strobe for image capture. If it is required that the green flash LEDs be the *only* illumination for image capture, then the internal illumination LEDs can be disabled.

### H-5-2 Target Pattern

Usage:	Assists users in positioning and locating symbols in the center of the reader's field of view.
Definition:	The user can control when the targeting system is ON or OFF, and can save this condition for power-on.
Serial Cmd:	<K750,green flash mode,target pattern status,green flash duration>
Default:	Always ON
Options:	0 = Always OFF 1 = ON only when not in the read cycle 2 = ON only when in the read cycle 3 = Always ON

## Always OFF

The target pattern will remain OFF at all times unless overridden by an operational command.

## ON Only When Not in the Read Cycle

The target pattern is always ON except during the read cycle. If the operational command overrides this setting, the target pattern will remain on at all times.

## ON Only When in the Read Cycle

The target pattern will remain OFF except during the read cycle. If the operational command overrides this setting, the target pattern will remain on at all times.

## Always ON

The target pattern is always ON.

### H-5-3 Green Flash Duration

Usage:	Provides visual verification that a good read has occurred.
Definition:	When a good read occurs, the green LEDs will illuminate and stay on for the time set in the <b>Green Flash Duration</b> value.
Serial Cmd:	<K750,green flash mode,target pattern status,green flash duration>
Default:	<b>25</b> (250ms)
Options:	0 to 65535 (in 10 ms increments)



## H-6 LED Configuration

Usage:	Useful as a visible indicator of read rates and symbol quality.	
Definition:	Determines the mode in which the status LEDs operate.	
Serial Cmd:	<K737,LED mode,ISO/IEC 16022 grade>	
Default:	Standard	
Options:	0 = Standard	1 = ISO/IEC 16022 grade

In ISO/IEC 16022 grade mode the LEDs represent the grade of the first Data Matrix symbol decoded in the read cycle.

The parameter to be graded is set in the **ISO/IEC 16022 Grade** options.

For example, to program the LEDs to indicate the ISO/IEC 16022 print growth grade, set **LED Mode** to **ISO/IEC 16022 Grade** and set **ISO/IEC 16022 Grade** to **Print Growth**. If all the LEDs from 20% to 100% are illuminated, the read result is a grade A; if only the 20% LED is illuminated, the result is a grade F.

### H-6-1 Standard

In **Standard Mode**, the STATUS LED indicates read cycle status and the GOOD READ LED illuminates upon a good read at the end of a read cycle. In a read rate test, these LEDs represent the percentage of good reads per images captured.

### H-6-2 ISO/IEC 16022 Grade

Usage:	Provides visual grading of specific ISO/IEC 16022 parameters.	
Definition:	Determines which ISO/IEC 16022 parameter the reader will grade via the LEDs.	
Serial Cmd:	<K737,LED mode,ISO/IEC 16022 grade>	
Default:	Final Grade	
Options:	0 = Final Grade	
	1 = Symbol Contrast	
	2 = Print Growth	
	3 = Axial Non-Uniformity	
	4 = Unused ECC	

## H-7 Serial Verification

Allows the user to verify configuration command status.

### H-7-1 Serial Command Echo Status

**Usage:** This command is useful in removing any doubt about the reader's interpretation of any configuration command.

For example, if the current preamble is "SOM" and **<K701,1, ,START>** is entered, the reader will echo back **<K701,SOM>** since the attempted entry "START" exceeds the four character limit for that command. Therefore, it is rejected and the existing "SOM" message is echoed back and remains the preamble message.

**Definition:** When enabled, a configuration command received from the host is echoed back to the host with the resultant settings.

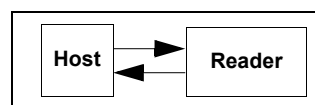

**Function:** If a command with multiple fields is processed, some of the fields may have been processed properly while others were not. The changes will appear in the string echoed back so that the user will know which fields did or did not change.

**Serial Cmd:** **<K701,serial command echo status, unused, control/hex output>**

**Default:** Disabled

**Options:** 0 = Disabled      1 = Enabled

### H-7-2 Control/Hex Output

**Usage:** Useful for viewing settings with binary characters when using serial commands on a terminal.

**Definition:** Determines the response to a **Serial Command Echo** or status request command.

When set to **Control**, two characters are transmitted to represent a non-displayable character. For example, a carriage return will be shown as: **^M**.

**Serial Cmd:** **<K701,serial command echo status, unused, control/hex output>**

**Default:** Control

**Options:** 0 = Control      1 = Hex

## H-8 Setup Button

The Setup button has four positions, selectable by the length of time the button is held down. Each position can be programmed for any of eight options.

Definition:	Serves as a master switch to enable/disable the Setup button status.
Serial Cmd:	< <b>K770,global status,default on power-on,load Configuration Database,save for power-on</b> >
Default:	Enabled
Options:	0 = Disabled 1 = Enabled 2 = Trigger 4 = Parameter Switch

### H-8-1 Global Status

#### Disabled

When set to **Disabled**, the Setup button does not function.

#### Enabled

When selected, the Setup button is enabled and the function of each button position is selected by the **Setup Button Mode** command.

#### Trigger

When selected, the Setup button acts as a trigger for the imager to start and end read cycles. All other button operations are inactive.

In External Level:	The read cycle endures for as long as the Setup button is pressed, unless a timeout occurs and <b>Timeout</b> is enabled for <b>End of Read Cycle</b> .
In External Edge:	As with <b>Level</b> , <b>Edge</b> allows a read cycle to be initiated by pressing the Setup button, but unlike <b>Level</b> , the read cycle ends with a good read output, a timeout, or a new trigger.

#### Parameter Switch

The parameter switch toggles between custom defaults and power-on settings. The condition is the same as that achieved by sending the <**Arc**> and <**Arp**> commands consecutively.

### H-8-2 Default on Power-On

Definition:	When enabled, if the Setup button is held down on power-on the imager will default to customer defaults and save for power-on. This is the same as sending a < <b>Zrc</b> > command.
Serial Cmd:	< <b>K770,global status,default on power-on,load Configuration Database,save for power-on</b> >
Default:	Enabled
Options:	0 = Disabled                      1 = Enabled

### H-8-3 Load Configuration Database

Definition: Allows the user to load the Configuration Database with calibration results. When the user performs a calibration using the Setup button, all the database entries are moved down one index and the results of the calibration are saved to index 1. The results will be saved as current settings as well.

Serial Cmd: *<K770,global status,default on power-on,load Configuration Database, save for power-on>*

Default: Enabled

Options: 0 = Disabled                      1 = Enabled

### H-8-4 Save for Power-On

Definition: If enabled, after calibration is complete, all parameters will be saved for power-on.

Serial Cmd: *<K770,global status,default on power-on,load Configuration Database, save for power-on>*

Default: Disabled

Options: 0 = Disabled                      1 = Enabled

# H-9 Setup Button Modes

Usage: Useful for performing multiple, repetitive tasks at the work site.

Definition: The global status field for the Setup button must be enabled for button processing to start. Once you press the button the reader will sequence through each button position. If you release the button after the button position but before the next button option starts, the reader will execute the action programmed for that button position. The status LEDs and the green flash will also illuminate to signal the current position. All button positions have the same configurable options. Also note that a quick press and release of the button before any button position is the same as if a position selected was configured as disabled.

Serial Cmd: <K771,button option 1,button option 2,button option 3,button option 4>

Options:

Button Option 1	Button Option 2	Button Option 3	Button Option 4
0 = Disabled	0 = Disabled	0 = Disabled	0 = Disabled
1 = Read Rate	1 = Read Rate	<b>1 = Read Rate</b>	1 = Read Rate
2 = Calibrate	<b>2 = Calibrate</b>	2 = Calibrate	2 = Calibrate
3 = Save for Power-On	3 = Save for Power-On	3 = Save for Power-On	<b>3 = Save for Power-On</b>
4 = Unused	4 = Unused	4 = Unused	4 = Unused
5 = Load New Master	5 = Load New Master	5 = Load New Master	5 = Load New Master
6 = Unused	6 = Unused	6 = Unused	6 = Unused
<b>7 = Target System</b>	7 = Target System	7 = Target System	7 = Target System
8 = Unused	8 = Unused	8 = Unused	8 = Unused
9 = Bar Code Config.	9 = Bar Code Config.	9 = Bar Code Config.	9 = Bar Code Config.

## Disabled

When set to disabled, the associated button position will have no function associated with it, and the position will be skipped over.

## Read Rate

Read Rate will be initiated when the associated button position is selected. Read Rate will perform decodes/second and is the same as sending a <C> from the terminal. To exit Read Rate Mode quickly press and release the Setup button.

## Calibrate

Calibration will be initiated when the associated button position is selected. To abort calibration, quickly press and release the Setup button.

## Save for Power-On

All imager settings will be saved to non-volatile memory to be recalled on power-on whenever the associated button position is selected. This is the same as sending a <Z> from the terminal.

## Load New Master

Functions in the same way as new master pin input whenever the associated button position is selected. The new master pin's **Consecutive Decode** requirement holds true for this function.

H

## Target System

---

Turns on the target pattern whenever the associated button position is selected. To disable, quickly press and release the Setup button.

- **Note:** This mode is the only one that does not require that the button be released before taking effect. If it is necessary to have the target system on before another operation such as calibration or read rate is performed, ensure that the target system mode is assigned a lower position so that it will be activated first.

## Bar Code Configuration

---

Enables bar code configuration mode whenever the associated button position is selected. When enabled, the imager can accept configuration commands from symbols. To disable, quickly press and release the Setup button.

## Setup Button Operation

---

To execute Setup button commands:

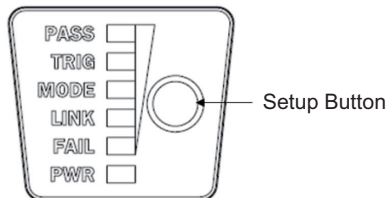

### ● Position 1

Hold down button until the 20% LED illuminates.

### ● Position 2

Hold down button until the 20% and 40% LEDs illuminate.

### ● Position 3

Hold down button until the 20%, 40%, and 60% LEDs illuminate.

### ● Position 4

Hold down button until the 20%, 40%, 60%, and 80% LEDs illuminate.

# H-10 Configurable Output 1

Usage:	This option provides discrete signalling to host software to control external devices such as PLCs and relays. It is useful for routing, sorting, and to prevent mis-packaging and mis-routing.
Definition:	Sets the discrete output functions for specific user-selected conditions. Allows the user to set the conditions under which an output (or outputs) will be activated.
Serial Cmd:	< <b>K810,output on,output state,pulse width,output mode</b> >
Default:	Mismatch or No-Read
Options:	0 = Mismatch or No-Read 1 = Match (or Good Read) 2 = Mismatch 3 = No-Read 4 = Trend Analysis 5 = Symbol Quality 6 = Diagnostic Warning 7 = In Read Cycle

- **Note:** If **Output On** is set to **Match** or **Mismatch**, a transition (switching) will not occur unless **Matchcode Type** is enabled and a master symbol is loaded into memory.

## Mismatch or No-Read

Activates discrete output when the data does not match that of the master symbol or the symbol has not been decoded before the end of the read cycle.

## Match (or Good Read)

Activates a discrete output when the symbol data matches the master symbol.

- **Note:** If you want to output for a good read and **Matchcode** is not enabled, you can enable any output for **Match**.

## Mismatch

Activates a discrete output whenever the symbol data does not match that of the master symbol.

## No-Read

Activates a discrete output whenever the symbol data is not decoded before the end of the read cycle.

## Trend Analysis

Usage:	Typically used when successful decodes are occurring but a discrete output is needed to flag a trend in quality issues.
Definition:	Activates discrete output when a trend analysis condition is met, depending on the trend analysis option enabled.

## Symbol Quality

Usage:	Typically used when a discrete indication is needed to flag a symbol quality condition.
Definition:	Activates discrete output when a symbol quality condition is met, depending on the symbol quality option enabled.

## Diagnostic Warning

Usage: Typically used when a discrete indication of a diagnostic condition is needed.  
 Definition: Activates discrete output when a diagnostic warning condition is met, depending on the diagnostic option enabled.

## In Read Cycle

Definition: Activates a discrete output when the reader is in a read cycle.

### H-10-1 Output State

Definition: Sets the active electrical state of the discrete output.  
 Serial Cmd: <K810,output on,output state,pulse width,output mode>  
 Default: Normally Open  
 Options: 0 = Normally Open                      1 = Normally Closed

### H-10-2 Pulse Width

Definition: Sets the time in 1 ms increments that the discrete output remains active.  
 Serial Cmd: <K810,output on,output state,pulse width,output mode>  
 Default: 500ms  
 Options: 0 to 65535(in 1 ms increments)

### H-10-3 Output Mode

Definition: Sets the condition in which the discrete output is de-activated.  
 Serial Cmd: <K810,output on,output state,pulse width,output mode>  
 Default: Pulse  
 Options: 0 = Pulse  
           2 = Latch Mode 2  
           3 = Latch Mode 3

## Pulse

This is the default mode of operation in which the programmable output is activated when the **Output On** condition has been met and held active for the duration of the selected pulse width.

### Latch Mode 2 (Unlatch Opposite Condition)

The programmable output is activated when the **Output On** condition has been met and held active until the opposite condition selected under **Output On** has been met.

For example, if **No-Read** is enabled under **Output On**, the programmable output will go active on a No-Read and remain active until the opposite condition, a good read, occurs.

### Latch Mode 3 (Unlatch Re-enter Read Cycle)

The programmable output is active when the Output On condition has been met and is held active until a new read cycle begins.

- **Note:** All of the **Output On** modes are inhibited when any **Output on Warning** is active for **Output 1**.



# H-11 Trend Analysis Output 1

Usage:	Useful in cases where the user doesn't want to shut down for one condition but wants to monitor quality and read conditions.
Definition:	Applies <b>Trend Analysis</b> settings to <b>Output 1</b> . With <b>Trend Analysis</b> , the user can track the occurrences and frequency of mismatches, No-Reads, and the number of reads per trigger, and output the results to any of three outputs.
Example:	Trend Analysis Mode = No-Read Trigger Evaluation Period= 25 triggers (read cycles) Number to Output On = 4 In this example, the reader will activate an output when 4 No-Reads occur within a period of 25 triggers (read cycles).

## H-11-1 Trend Analysis Mode

Definition:	Sets the trend condition ( <b>Mismatch</b> , <b>No-Read</b> , or <b>Decodes per Trigger</b> ) that will activate the output.
Serial Cmd:	< <b>K780</b> , <i>trend analysis mode</i> , <i>trigger evaluation period</i> , <i>number to output on</i> , <i>decodes per trigger threshold</i> >
Default:	No-Read
Options:	0 = Mismatch 1 = No-Read 2 = Decodes per Trigger

### Mismatch

Output will be activated when the number of mismatches equals the value entered for **Number to Output On** within the trigger window selected in **Number of Triggers**.

### No-Read

Output will be activated when the number of No-Reads equals the value entered for **Number to Output On** within the trigger window selected in **Number of Triggers**.

### Decodes per Trigger

Output will be activated when the number of decodes equals the value entered for **Number to Output On** within the trigger window selected in **Number of Triggers**.

H

## H-11-2 Trigger Evaluation Period

Definition:	The number of triggers to examine for the trend analysis condition.
Serial Cmd:	< <b>K780</b> , <i>trend analysis mode</i> , <i>trigger evaluation period</i> , <i>number to output on</i> , <i>decodes per trigger threshold</i> >
Default:	0
Options:	0 to 255

### H-11-3 Number to Output On

Usage:	<i>Example:</i> If <b>Number to Output On</b> is set to 3 and <b>Trend Analysis Mode</b> is set to <b>No-Read</b> , then the output will not be activated until 3 No-Reads have occurred.
Definition:	Sets the number of <b>Trend Analysis Mode</b> events (mismatches, No-Reads, or reads/trigger as configured by Trend Analysis Mode) to occur within the trigger evaluation period before activating the associated output.
Serial Cmd:	<i>&lt;K780,trend analysis mode,trigger evaluation period,number to output on,decodes per trigger threshold&gt;</i>
Default:	0
Options:	0 to 255

### H-11-4 Decodes per Trigger Threshold

Definition:	The appropriate output will be activated if, at the end of the read cycle, the symbol decode count is below this setting. <b>Note:</b> To activate this feature the reader must be in Decodes per Trigger mode. To put the reader in this mode during the read cycle and the Trend Analysis operation, the Decodes per Trigger status in the quality settings must be enabled. Enabling this setting will also append the decode count to the symbol data.
Serial Cmd:	<i>&lt;K780,trend analysis mode,trigger evaluation period,number to output on,decodes per trigger threshold&gt;</i>
Default:	0
Options:	0 to 65535

# H-12 ISO/IEC 16022 Symbol Quality Output 1

## ● Output on Symbol Contrast

Usage: Lets the user know if symbol quality is less than acceptable.  
 Definition: If enabled, toggles Output 1 to an active state when **Symbol Contrast Threshold** is met.  
 Serial Cmd: *<K800,output on symbol contrast,symbol contrast threshold,output on print growth,print growth threshold,output on axial non-uniformity,axial non-uniformity threshold,output on UEC,UEC threshold>*  
 Default: Disabled  
 Options: 0 = Disabled                      1 = Enabled

## ● Output on Print Growth

Usage: Lets the user know if symbol quality is less than acceptable.  
 Definition: If enabled, toggles **Output 1** to an active state when **Print Growth Threshold** is met.  
 Serial Cmd: *<K800,output on symbol contrast,symbol contrast threshold,output on print growth,print growth threshold,output on axial non-uniformity,axial non-uniformity threshold,output on UEC,UEC threshold>*  
 Default: Disabled  
 Options: 0 = Disabled                      1 = Enabled

## ● Output on Axial Non-Uniformity

Usage: Lets the user know if symbol quality is less than acceptable.  
 Definition: If enabled, toggles **Output 1** to an active state when **Axial Non-Uniformity Threshold** is met.  
 Serial Cmd: *<K800,output on symbol contrast,symbol contrast threshold,output on print growth,print growth threshold,output on axial non-uniformity,axial non-uniformity threshold,output on UEC,UEC threshold>*  
 Default: Disabled  
 Options: 0 = Disabled                      1 = Enabled

## ● Output on Unused Error Correction

Usage: Lets the user know if symbol quality is less than acceptable.  
 Definition: If enabled, toggles **Output 1** to an active state when **UEC Threshold** is met.  
 Serial Cmd: *<K800,output on symbol contrast,symbol contrast threshold,output on print growth,print growth threshold,output on axial non-uniformity,axial non-uniformity threshold,output on UEC,UEC threshold>*  
 Default: Disabled  
 Options: 0 = Disabled                      1 = Enabled

### ● Symbol Contrast Threshold

Usage:	Lets the user set the acceptable level of symbol quality.
Definition:	Conforms to ISO/IEC 16022 symbol quality grading (A,B,C,D).
Serial Cmd:	< <b>K800</b> ,output on symbol contrast, <b>symbol contrast threshold</b> ,output on print growth,print growth threshold,output on axial non-uniformity,axial non-uniformity threshold,output on UEC,UEC threshold>
Default:	Grade C
Options:	0 = Grade A 1 = Grade B 2 = Grade C 3 = Grade D

### ● Print Growth Threshold

Usage:	Lets the user set the acceptable level of symbol quality.
Definition:	Conforms to ISO/IEC 16022 symbol quality grading (A,B,C,D).
Serial Cmd:	< <b>K800</b> ,output on symbol contrast,symbol contrast threshold,output on print growth, <b>print growth threshold</b> ,output on axial non-uniformity,axial non-uniformity threshold,output on UEC,UEC threshold>
Default:	Grade C
Options:	0 = Grade A 1 = Grade B 2 = Grade C 3 = Grade D

### ● Axial Non-Uniformity Threshold

Usage:	Lets the user set the acceptable level of symbol quality.
Definition:	Conforms to ISO/IEC 16022 symbol quality grading (A,B,C,D).
Serial Cmd:	< <b>K800</b> ,output on symbol contrast,symbol contrast threshold,output on print growth,print growth threshold,output on axial non-uniformity, <b>axial non-uniformity threshold</b> ,output on UEC,UEC threshold>
Default:	Grade C
Options:	0 = Grade A 1 = Grade B 2 = Grade C 3 = Grade D

### ● Unused Error Correction Threshold

Usage:	Lets the user set the acceptable level of symbol quality.
Definition:	Conforms to ISO/IEC 16022 symbol quality grading (A,B,C,D).
Serial Cmd:	< <b>K800</b> ,output on symbol contrast,symbol contrast threshold,output on print growth,print growth threshold,output on axial non-uniformity,axial non-uniformity threshold,output on UEC, <b>UEC threshold</b> >
Default:	Grade C
Options:	0 = Grade A 1 = Grade B 2 = Grade C 3 = Grade D

# H-13 ISO/IEC 15415 Symbol Quality Output 1

## Barcode Symbol Print Quality Test Specification – 2D Symbols

### Supported symbologies:

- Data Matrix ECC200
- QR Code
- Micro QR Code

Minimum Resolution: 6.0 Pixels Per Element

### ● Output on Overall Grade

Usage: Lets the user know if symbol quality is less than acceptable.  
 Definition: If enabled, drives **Output** if grade is under **Overall Grade Threshold**.  
 Serial Cmd: <**K870, output on overall grade**, overall grade threshold, symbol contrast, symbol contrast threshold, modulation, modulation threshold, reflectance margin, reflectance margin threshold, fixed pattern damage, fixed pattern damage threshold, axial non-uniformity, axial non-uniformity threshold, grid non-uniformity, grid non-uniformity threshold, unused ECC, unused ECC threshold>  
 Default: Disabled  
 Options: 0 = Disabled                      1 = Enabled

### ● Overall Grade Threshold

Usage: Sets the threshold for driving the output.  
 Definition: Conforms to ISO/IEC 15415 symbol quality grading (A,B,C,D).  
 Serial Cmd: <**K870, output on overall grade, overall grade threshold**, symbol contrast, symbol contrast threshold, modulation, modulation threshold, reflectance margin, reflectance margin threshold, fixed pattern damage, fixed pattern damage threshold, axial non-uniformity, axial non-uniformity threshold, grid non-uniformity, grid non-uniformity threshold, unused ECC, unused ECC threshold>  
 Default: Grade B  
 Options: 0 = Grade D  
           1 = Grade C  
           2 = Grade B  
           3 = Grade A

## ● Symbol Contrast

Usage:	Lets the user know if symbol quality is less than acceptable.	
Definition:	If enabled, drives <b>Output</b> if grade is under <b>Symbol Contrast Threshold</b> .	
Serial Cmd:	< <b>K870</b> , output on overall grade, overall grade threshold, <b>symbol contrast</b> , symbol contrast threshold, modulation, modulation threshold, reflectance margin, reflectance margin threshold, fixed pattern damage, fixed pattern damage threshold, axial non-uniformity, axial non-uniformity threshold, grid non-uniformity, grid non-uniformity threshold, unused ECC, unused ECC threshold>	
Default:	Disabled	
Options:	0 = Disabled	1 = Enabled

## ● Symbol Contrast Threshold

Usage:	Sets the threshold for driving the output.	
Definition:	Conforms to ISO/IEC 15415 symbol quality grading (A,B,C,D).	
Serial Cmd:	< <b>K870</b> , output on overall grade, overall grade threshold, symbol contrast, <b>symbol contrast threshold</b> , modulation, modulation threshold, reflectance margin, reflectance margin threshold, fixed pattern damage, fixed pattern damage threshold, axial non-uniformity, axial non-uniformity threshold, grid non-uniformity, grid non-uniformity threshold, unused ECC, unused ECC threshold>	
Default:	Grade B	
Options:	0 = Grade D	
	1 = Grade C	
	2 = Grade B	
	3 = Grade A	

## ● Modulation

Usage:	Lets the user know if symbol quality is less than acceptable.	
Definition:	If enabled, drives <b>Output</b> if grade is under <b>Modulation Threshold</b> .	
Serial Cmd:	< <b>K870</b> , output on overall grade, overall grade threshold, symbol contrast, symbol contrast threshold, <b>modulation</b> , modulation threshold, reflectance margin, reflectance margin threshold, fixed pattern damage, fixed pattern damage threshold, axial non-uniformity, axial non-uniformity threshold, grid non-uniformity, grid non-uniformity threshold, unused ECC, unused ECC threshold>	
Default:	Disabled	
Options:	0 = Disabled	1 = Enabled

## ● Modulation Threshold

Usage:	Sets the threshold for driving the output.	
Definition:	Conforms to ISO/IEC 15415 symbol quality grading (A,B,C,D).	
Serial Cmd:	< <b>K870</b> , output on overall grade, overall grade threshold, symbol contrast, symbol contrast threshold, modulation, <b>modulation threshold</b> , reflectance margin, reflectance margin threshold, fixed pattern damage, fixed pattern damage threshold, axial non-uniformity, axial non-uniformity threshold, grid non-uniformity, grid non-uniformity threshold, unused ECC, unused ECC threshold>	
Default:	Grade B	
Options:	0 = Grade D	
	1 = Grade C	
	2 = Grade B	
	3 = Grade A	

### ● Reflectance Margin

Usage:	Lets the user know if symbol quality is less than acceptable.	
Definition:	If enabled, drives <b>Output</b> if grade is under <b>Reflectance Margin Threshold</b> .	
Serial Cmd:	< <b>K870</b> , output on overall grade, overall grade threshold, symbol contrast, symbol contrast threshold, modulation, modulation threshold, <b>reflectance margin</b> , reflectance margin threshold, fixed pattern damage, fixed pattern damage threshold, axial non-uniformity, axial non-uniformity threshold, grid non-uniformity, grid non-uniformity threshold, unused ECC, unused ECC threshold>	
Default:	Disabled	
Options:	0 = Disabled	1 = Enabled

### ● Reflectance Margin Threshold

Usage:	Sets the threshold for driving the output.	
Definition:	Conforms to ISO/IEC 15415 symbol quality grading (A,B,C,D).	
Serial Cmd:	< <b>K870</b> , output on overall grade, overall grade threshold, symbol contrast, symbol contrast threshold, modulation, modulation threshold, reflectance margin, <b>reflectance margin threshold</b> , fixed pattern damage, fixed pattern damage threshold, axial non-uniformity, axial non-uniformity threshold, grid non-uniformity, grid non-uniformity threshold, unused ECC, unused ECC threshold>	
Default:	Grade B	
Options:	0 = Grade D	
	1 = Grade C	
	2 = Grade B	
	3 = Grade A	

### ● Fixed Pattern Damage

Usage:	Lets the user know if symbol quality is less than acceptable.	
Definition:	If enabled, drives <b>Output</b> if grade is under <b>Fixed Pattern Damage Threshold</b> .	
Serial Cmd:	< <b>K870</b> , output on overall grade, overall grade threshold, symbol contrast, symbol contrast threshold, modulation, modulation threshold, reflectance margin, reflectance margin threshold, <b>fixed pattern damage</b> , fixed pattern damage threshold, axial non-uniformity, axial non-uniformity threshold, grid non-uniformity, grid non-uniformity threshold, unused ECC, unused ECC threshold>	
Default:	Disabled	
Options:	0 = Disabled	1 = Enabled

### ● Fixed Pattern Damage Threshold

Usage:	Sets the threshold for driving the output.	
Definition:	Conforms to ISO/IEC 15415 symbol quality grading (A,B,C,D).	
Serial Cmd:	< <b>K870</b> , output on overall grade, overall grade threshold, symbol contrast, symbol contrast threshold, modulation, modulation threshold, reflectance margin, reflectance margin threshold, fixed pattern damage, <b>fixed pattern damage threshold</b> , axial non-uniformity, axial non-uniformity threshold, grid non-uniformity, grid non-uniformity threshold, unused ECC, unused ECC threshold>	
Default:	Grade B	
Options:	0 = Grade D	
	1 = Grade C	
	2 = Grade B	
	3 = Grade A	

● **Axial Non-uniformity**

Usage: Lets the user know if symbol quality is less than acceptable.  
 Definition: If enabled, drives **Output** if grade is under **Axial Non-uniformity Threshold**.  
 Serial Cmd: <**K870**, output on overall grade, overall grade threshold, symbol contrast, symbol contrast threshold, modulation, modulation threshold, reflectance margin, reflectance margin threshold, fixed pattern damage, fixed pattern damage threshold, **axial non-uniformity**, axial non-uniformity threshold, grid non-uniformity, grid non-uniformity threshold, unused ECC, unused ECC threshold>  
 Default: Disabled  
 Options: 0 = Disabled 1 = Enabled

● **Axial Non-uniformity Threshold**

Usage: Sets the threshold for driving the output.  
 Definition: Conforms to ISO/IEC 15415 symbol quality grading (A,B,C,D).  
 Serial Cmd: <**K870**, output on overall grade, overall grade threshold, symbol contrast, symbol contrast threshold, modulation, modulation threshold, reflectance margin, reflectance margin threshold, fixed pattern damage, fixed pattern damage threshold, axial non-uniformity, **axial non-uniformity threshold**, grid non-uniformity, grid non-uniformity threshold, unused ECC, unused ECC threshold>  
 Default: Grade B  
 Options: 0 = Grade D  
 1 = Grade C  
 2 = Grade B  
 3 = Grade A

● **Grid Non-uniformity**

Usage: Lets the user know if symbol quality is less than acceptable.  
 Definition: If enabled, drives **Output** if grade is under **Grid Non-uniformity Threshold**.  
 Serial Cmd: <**K870**, output on overall grade, overall grade threshold, symbol contrast, symbol contrast threshold, modulation, modulation threshold, reflectance margin, reflectance margin threshold, fixed pattern damage, fixed pattern damage threshold, axial non-uniformity, axial non-uniformity threshold, **grid non-uniformity**, grid non-uniformity threshold, unused ECC, unused ECC threshold>  
 Default: Disabled  
 Options: 0 = Disabled 1 = Enabled

● **Grid Non-uniformity Threshold**

Usage: Sets the threshold for driving the output.  
 Definition: Conforms to ISO/IEC 15415 symbol quality grading (A,B,C,D).  
 Serial Cmd: <**K870**, output on overall grade, overall grade threshold, symbol contrast, symbol contrast threshold, modulation, modulation threshold, reflectance margin, reflectance margin threshold, fixed pattern damage, fixed pattern damage threshold, axial non-uniformity, axial non-uniformity threshold, grid non-uniformity, **grid non-uniformity threshold**, unused ECC, unused ECC threshold>  
 Default: Grade B  
 Options: 0 = Grade D  
 1 = Grade C  
 2 = Grade B  
 3 = Grade A



## ● Unused ECC

Usage:	Lets the user know if symbol quality is less than acceptable.	
Definition:	If enabled, drives <b>Output</b> if grade is under <b>Unused ECC Threshold</b> .	
Serial Cmd:	< <b>K870</b> , output on overall grade, overall grade threshold, symbol contrast, symbol contrast threshold, modulation, modulation threshold, reflectance margin, reflectance margin threshold, fixed pattern damage, fixed pattern damage threshold, axial non-uniformity, axial non-uniformity threshold, grid non-uniformity, grid non-uniformity threshold, <b>unused ECC</b> , unused ECC threshold>	
Default:	Disabled	
Options:	0 = Disabled	1 = Enabled

## ● Unused ECC Threshold

Usage:	Sets the threshold for driving the output.	
Definition:	Conforms to ISO/IEC 15415 symbol quality grading (A,B,C,D).	
Serial Cmd:	< <b>K870</b> , output on overall grade, overall grade threshold, symbol contrast, symbol contrast threshold, modulation, modulation threshold, reflectance margin, reflectance margin threshold, fixed pattern damage, fixed pattern damage threshold, axial non-uniformity, axial non-uniformity threshold, grid non-uniformity, grid non-uniformity threshold, unused ECC, <b>unused ECC threshold</b> >	
Default:	Grade B	
Options:	0 = Grade D	
	1 = Grade C	
	2 = Grade B	
	3 = Grade A	

# H-14 ISO/IEC 15416 Symbol Quality Output 1

## Barcode Print Quality Guideline

### Supported Symbologies:

- Code 128 / GS1-128
- UPC-A / UPC-E / EAN-13 / EAN-8
- Interleaved 2 of 5 / ITF-14
- Code 39
- Code 93
- Codabar

Minimum Resolution: 4.0 Pixels Per Element

### ● Output on Overall Grade

Usage: Lets the user know if symbol quality is less than acceptable.  
 Definition: If enabled, drives **Output** if grade is under **Overall Grade Threshold**.  
 Serial Cmd: <**K880, output on overall grade**, overall grade threshold, edge determination, edge determination threshold, decode, decode threshold, contrast, contrast threshold, min reflectance, min reflectance threshold, min edge contrast, min edge contrast threshold, modulation, modulation threshold, defects, defects threshold, decodability, decodability threshold, quiet Zone, quiet zone threshold >  
 Default: Disabled  
 Options: 0 = Disabled                      1 = Enabled

### ● Overall Grade Threshold

Usage: Sets the threshold for driving the output.  
 Definition: Conforms to ISO/IEC 15416 symbol quality grading (A,B,C,D).  
 Serial Cmd: <**K880, output on overall grade, overall grade threshold**, edge determination, edge determination threshold, decode, decode threshold, contrast, contrast threshold, min reflectance, min reflectance threshold, min edge contrast, min edge contrast threshold, modulation, modulation threshold, defects, defects threshold, decodability, decodability threshold, quiet Zone, quiet zone threshold >  
 Default: Grade B  
 Options: 0 = Grade D  
           1 = Grade C  
           2 = Grade B  
           3 = Grade A

## ● Edge Determination

Usage:	Lets the user know if symbol quality is less than acceptable.	
Definition:	If enabled, drives <b>Output</b> if grade is under <b>Edge Determination Threshold</b> .	
Serial Cmd:	< <b>K880</b> , output on overall grade, overall grade threshold, <b>edge determination</b> , edge determination threshold, decode, decode threshold, contrast, contrast threshold, min reflectance, min reflectance threshold, min edge contrast, min edge contrast threshold, modulation, modulation threshold, defects, defects threshold, decodability, decodability threshold, quiet Zone, quiet zone threshold >	
Default:	Disabled	
Options:	0 = Disabled	1 = Enabled

## ● Edge Determination Threshold

Usage:	Sets the threshold for driving the output.	
Definition:	Conforms to ISO/IEC 15416 symbol quality grading (A,B,C,D).	
Serial Cmd:	< <b>K880</b> , output on overall grade, overall grade threshold, edge determination, <b>edge determination threshold</b> , decode, decode threshold, contrast, contrast threshold, min reflectance, min reflectance threshold, min edge contrast, min edge contrast threshold, modulation, modulation threshold, defects, defects threshold, decodability, decodability threshold, quiet Zone, quiet zone threshold >	
Default:	Grade B	
Options:	0 = Grade D	1 = Grade C
	2 = Grade B	3 = Grade A

## ● Decode

Usage:	Lets the user know if symbol quality is less than acceptable.	
Definition:	If enabled, drives <b>Output</b> if grade is under <b>Decode Threshold</b> .	
Serial Cmd:	< <b>K880</b> , output on overall grade, overall grade threshold, edge determination, edge determination threshold, <b>decode</b> , decode threshold, contrast, contrast threshold, min reflectance, min reflectance threshold, min edge contrast, min edge contrast threshold, modulation, modulation threshold, defects, defects threshold, decodability, decodability threshold, quiet Zone, quiet zone threshold >	
Default:	Disabled	
Options:	0 = Disabled	1 = Enabled

## ● Decode Threshold

Usage:	Sets the threshold for driving the output.	
Definition:	Conforms to ISO/IEC 15416 symbol quality grading (A,B,C,D).	
Serial Cmd:	< <b>K880</b> , output on overall grade, overall grade threshold, edge determination, edge determination threshold, decode, <b>decode threshold</b> , contrast, contrast threshold, min reflectance, min reflectance threshold, min edge contrast, min edge contrast threshold, modulation, modulation threshold, defects, defects threshold, decodability, decodability threshold, quiet Zone, quiet zone threshold >	
Default:	Grade B	
Options:	0 = Grade D	1 = Grade C
	2 = Grade B	3 = Grade A

● **Contrast**

Usage: Lets the user know if symbol quality is less than acceptable.  
 Definition: If enabled, drives **Output** if grade is under **Contrast Threshold**.  
 Serial Cmd: <**K880**, output on overall grade, overall grade threshold, edge determination, edge determination threshold, decode, decode threshold, **contrast**, contrast threshold, min reflectance, min reflectance threshold, min edge contrast, min edge contrast threshold, modulation, modulation threshold, defects, defects threshold, decodability, decodability threshold, quiet Zone, quiet zone threshold >  
 Default: Disabled  
 Options: 0 = Disabled 1 = Enabled

● **Contrast Threshold**

Usage: Sets the threshold for driving the output.  
 Definition: Conforms to ISO/IEC 15416 symbol quality grading (A,B,C,D).  
 Serial Cmd: <**K880**, output on overall grade, overall grade threshold, edge determination, edge determination threshold, decode, decode threshold, contrast, **contrast threshold**, min reflectance, min reflectance threshold, min edge contrast, min edge contrast threshold, modulation, modulation threshold, defects, defects threshold, decodability, decodability threshold, quiet Zone, quiet zone threshold >  
 Default: Grade B  
 Options: 0 = Grade D  
 1 = Grade C  
 2 = Grade B  
 3 = Grade A

● **Min Reflectance**

Usage: Lets the user know if symbol quality is less than acceptable.  
 Definition: If enabled, drives **Output** if grade is under **Min Reflectance Threshold**.  
 Serial Cmd: <**K880**, output on overall grade, overall grade threshold, edge determination, edge determination threshold, decode, decode threshold, contrast, contrast threshold, **min reflectance**, min reflectance threshold, min edge contrast, min edge contrast threshold, modulation, modulation threshold, defects, defects threshold, decodability, decodability threshold, quiet Zone, quiet zone threshold >  
 Default: Disabled  
 Options: 0 = Disabled 1 = Enabled

● **Min Reflectance Threshold**

Usage: Sets the threshold for driving the output.  
 Definition: Conforms to ISO/IEC 15416 symbol quality grading (A,B,C,D).  
 Serial Cmd: <**K880**, output on overall grade, overall grade threshold, edge determination, edge determination threshold, decode, decode threshold, contrast, contrast threshold, min reflectance, **min reflectance threshold**, min edge contrast, min edge contrast threshold, modulation, modulation threshold, defects, defects threshold, decodability, decodability threshold, quiet Zone, quiet zone threshold >  
 Default: Grade B  
 Options: 0 = Grade D  
 1 = Grade C  
 2 = Grade B  
 3 = Grade A

### ● Min Edge Contrast

Usage:	Lets the user know if symbol quality is less than acceptable.	
Definition:	If enabled, drives <b>Output</b> if grade is under <b>Min Edge Contrast Threshold</b> .	
Serial Cmd:	< <b>K880</b> , output on overall grade, overall grade threshold, edge determination, edge determination threshold, decode, decode threshold, contrast, contrast threshold, min reflectance, min reflectance threshold, <b>min edge contrast</b> , min edge contrast threshold, modulation, modulation threshold, defects, defects threshold, decodability, decodability threshold, quiet Zone, quiet zone threshold >	
Default:	Disabled	
Options:	0 = Disabled	1 = Enabled

### ● Min Edge Contrast Threshold

Usage:	Sets the threshold for driving the output.	
Definition:	Conforms to ISO/IEC 15416 symbol quality grading (A,B,C,D).	
Serial Cmd:	< <b>K880</b> , output on overall grade, overall grade threshold, edge determination, edge determination threshold, decode, decode threshold, contrast, contrast threshold, min reflectance, min reflectance threshold, min edge contrast, <b>min edge contrast threshold</b> , modulation, modulation threshold, defects, defects threshold, decodability, decodability threshold, quiet Zone, quiet zone threshold >	
Default:	Grade B	
Options:	0 = Grade D	1 = Grade C
	2 = Grade B	3 = Grade A

### ● Modulation

Usage:	Lets the user know if symbol quality is less than acceptable.	
Definition:	If enabled, drives <b>Output</b> if grade is under <b>Modulation Threshold</b> .	
Serial Cmd:	< <b>K880</b> , output on overall grade, overall grade threshold, edge determination, edge determination threshold, decode, decode threshold, contrast, contrast threshold, min reflectance, min reflectance threshold, min edge contrast, min edge contrast threshold, <b>modulation</b> , modulation threshold, defects, defects threshold, decodability, decodability threshold, quiet Zone, quiet zone threshold >	
Default:	Disabled	
Options:	0 = Disabled	1 = Enabled

### ● Modulation Threshold

Usage:	Sets the threshold for driving the output.	
Definition:	Conforms to ISO/IEC 15416 symbol quality grading (A,B,C,D).	
Serial Cmd:	< <b>K880</b> , output on overall grade, overall grade threshold, edge determination, edge determination threshold, decode, decode threshold, contrast, contrast threshold, min reflectance, min reflectance threshold, min edge contrast, min edge contrast threshold, modulation, <b>modulation threshold</b> , defects, defects threshold, decodability, decodability threshold, quiet Zone, quiet zone threshold >	
Default:	Grade B	
Options:	0 = Grade D	1 = Grade C
	2 = Grade B	3 = Grade A

● **Defects**

Usage: Lets the user know if symbol quality is less than acceptable.  
 Definition: If enabled, drives **Output** if grade is under **Defects Threshold**.  
 Serial Cmd: <**K880**, output on overall grade, overall grade threshold, edge determination, edge determination threshold, decode, decode threshold, contrast, contrast threshold, min reflectance, min reflectance threshold, min edge contrast, min edge contrast threshold, modulation, modulation threshold, **defects**, defects threshold, decodability, decodability threshold, quiet Zone, quiet zone threshold >  
 Default: Disabled  
 Options: 0 = Disabled 1 = Enabled

● **Defects Threshold**

Usage: Sets the threshold for driving the output.  
 Definition: Conforms to ISO/IEC 15416 symbol quality grading (A,B,C,D).  
 Serial Cmd: <**K880**, output on overall grade, overall grade threshold, edge determination, edge determination threshold, decode, decode threshold, contrast, contrast threshold, min reflectance, min reflectance threshold, min edge contrast, min edge contrast threshold, modulation, modulation threshold, defects, **defects threshold**, decodability, decodability threshold, quiet Zone, quiet zone threshold >  
 Default: Grade B  
 Options: 0 = Grade D  
 1 = Grade C  
 2 = Grade B  
 3 = Grade A

● **Decodability**

Usage: Lets the user know if symbol quality is less than acceptable.  
 Definition: If enabled, drives **Output** if grade is under **Decodability Threshold**.  
 Serial Cmd: <**K880**, output on overall grade, overall grade threshold, edge determination, edge determination threshold, decode, decode threshold, contrast, contrast threshold, min reflectance, min reflectance threshold, min edge contrast, min edge contrast threshold, modulation, modulation threshold, defects, defects threshold, **decodability**, decodability threshold, quiet Zone, quiet zone threshold >  
 Default: Disabled  
 Options: 0 = Disabled 1 = Enabled

● **Decodability Threshold**

Usage: Sets the threshold for driving the output.  
 Definition: Conforms to ISO/IEC 15416 symbol quality grading (A,B,C,D).  
 Serial Cmd: <**K880**, output on overall grade, overall grade threshold, edge determination, edge determination threshold, decode, decode threshold, contrast, contrast threshold, min reflectance, min reflectance threshold, min edge contrast, min edge contrast threshold, modulation, modulation threshold, defects, defects threshold, decodability, **decodability threshold**, quiet Zone, quiet zone threshold >  
 Default: Grade B  
 Options: 0 = Grade D  
 1 = Grade C  
 2 = Grade B  
 3 = Grade A

## ● Quiet Zone

Usage:	Lets the user know if symbol quality is less than acceptable.	
Definition:	If enabled, drives <b>Output</b> if grade is under <b>Quiet Zone Threshold</b> .	
Serial Cmd:	< <b>K880</b> , output on overall grade, overall grade threshold, edge determination, edge determination threshold, decode, decode threshold, contrast, contrast threshold, min reflectance, min reflectance threshold, min edge contrast, min edge contrast threshold, modulation, modulation threshold, defects, defects threshold, decodability, decodability threshold, <b>quiet Zone</b> , quiet zone threshold >	
Default:	Disabled	
Options:	0 = Disabled	1 = Enabled

## ● Quiet Zone Threshold

Usage:	Sets the threshold for driving the output.	
Definition:	Conforms to ISO/IEC 15416 symbol quality grading (A,B,C,D).	
Serial Cmd:	< <b>K880</b> , output on overall grade, overall grade threshold, edge determination, edge determination threshold, decode, decode threshold, contrast, contrast threshold, min reflectance, min reflectance threshold, min edge contrast, min edge contrast threshold, modulation, modulation threshold, defects, defects threshold, decodability, decodability threshold, quiet Zone, <b>quiet zone threshold</b> >	
Default:	Grade B	
Options:	0 = Grade D	
	1 = Grade C	
	2 = Grade B	
	3 = Grade A	

# H-15 ISO/IEC 29158 Symbol Quality Output 1

## Automatic Identification and data capture – Direct Part Mark (DMP) Quality

### Supported symbologies:

- Data Matrix ECC200

Minimum Resolution: 6.0 Pixels Per Element

### ● Output on Overall Grade

Usage: Lets the user know if symbol quality is less than acceptable.  
 Definition: If enabled, drives Output if grade is under Overall Grade Threshold.  
 Serial Cmd: <K890, output on overall grade, overall grade threshold, cell contrast, cell contrast threshold, cell modulation, cell modulation threshold, fixed pattern damage, fixed pattern damage threshold, axial non-uniformity, axial non-uniformity threshold, grid non-uniformity, grid non-uniformity threshold, unused ECC, unused ECC threshold>  
 Default: Disabled  
 Options: 0 = Disabled 1 = Enabled

### ● Overall Grade Threshold

Usage: Sets the threshold for driving the output.  
 Definition: Conforms to ISO/IEC 29158 symbol quality grading (A,B,C,D).  
 Serial Cmd: <K890, output on overall grade, overall grade threshold, cell contrast, cell contrast threshold, cell modulation, cell modulation threshold, fixed pattern damage, fixed pattern damage threshold, axial non-uniformity, axial non-uniformity threshold, grid non-uniformity, grid non-uniformity threshold, unused ECC, unused ECC threshold>  
 Default: Grade B  
 Options: 0 = Grade D  
 1 = Grade C  
 2 = Grade B  
 3 = Grade A

### ● Cell Contrast

Usage: Lets the user know if symbol quality is less than acceptable.  
 Definition: If enabled, drives **Output** if grade is under **Symbol Contrast Threshold**.  
 Serial Cmd: <K890, output on overall grade, overall grade threshold, cell contrast, cell contrast threshold, cell modulation, cell modulation threshold, fixed pattern damage, fixed pattern damage threshold, axial non-uniformity, axial non-uniformity threshold, grid non-uniformity, grid non-uniformity threshold, unused ECC, unused ECC threshold>  
 Default: Disabled  
 Options: 0 = Disabled 1 = Enabled



### ● Cell Contrast Threshold

Usage:	Sets the threshold for driving the output.	
Definition:	Conforms to ISO/IEC 29158 symbol quality grading (A,B,C,D).	
Serial Cmd:	< <b>K890</b> , output on overall grade, overall grade threshold, cell contrast, <b>cell contrast threshold</b> , cell modulation, cell modulation threshold, fixed pattern damage, fixed pattern damage threshold, axial non-uniformity, axial non-uniformity threshold, grid non-uniformity, grid non-uniformity threshold, unused ECC, unused ECC threshold>	
Default:	Grade B	
Options:	0 = Grade D 1 = Grade C 2 = Grade B 3 = Grade A	

### ● Cell Moduration

Usage:	Lets the user know if symbol quality is less than acceptable.	
Definition:	If enabled, drives <b>Output</b> if grade is under <b>Cell Moduration Threshold</b> .	
Serial Cmd:	< <b>K890</b> , output on overall grade, overall grade threshold, cell contrast, cell contrast threshold, <b>cell modulation</b> , cell modulation threshold, fixed pattern damage, fixed pattern damage threshold, axial non-uniformity, axial non-uniformity threshold, grid non-uniformity, grid non-uniformity threshold, unused ECC, unused ECC threshold>	
Default:	Disabled	
Options:	0 = Disabled	1 = Enabled

### ● Cell Moduration Threshold

Usage:	Sets the threshold for driving the output.	
Definition:	Conforms to ISO/IEC 29158 symbol quality grading (A,B,C,D).	
Serial Cmd:	< <b>K890</b> , output on overall grade, overall grade threshold, cell contrast, cell contrast threshold, cell modulation, <b>cell modulation threshold</b> , fixed pattern damage, fixed pattern damage threshold, axial non-uniformity, axial non-uniformity threshold, grid non-uniformity, grid non-uniformity threshold, unused ECC, unused ECC threshold>	
Default:	Grade B	
Options:	0 = Grade D 1 = Grade C 2 = Grade B 3 = Grade A	

### ● Fixed Pattern Damage

Usage:	Lets the user know if symbol quality is less than acceptable.	
Definition:	If enabled, drives <b>Output</b> if grade is under <b>Fixed Pattern Damage Threshold</b> .	
Serial Cmd:	< <b>K890</b> , output on overall grade, overall grade threshold, cell contrast, cell contrast threshold, cell modulation, <b>cell modulation threshold</b> , fixed pattern damage, fixed pattern damage threshold, axial non-uniformity, axial non-uniformity threshold, grid non-uniformity, grid non-uniformity threshold, unused ECC, unused ECC threshold>	
Default:	Disabled	
Options:	0 = Disabled	1 = Enabled

● **Fixed Pattern Damage Threshold**

Usage: Sets the threshold for driving the output.  
 Definition: Conforms to ISO/IEC 29158 symbol quality grading (A,B,C,D).  
 Serial Cmd: <**K890**, output on overall grade, overall grade threshold, cell contrast, cell contrast threshold, cell modulation, cell modulation threshold, fixed pattern damage, **fixed pattern damage threshold**, axial non-uniformity, axial non-uniformity threshold, grid non-uniformity, grid non-uniformity threshold, unused ECC, unused ECC threshold>  
 Default: Grade B  
 Options: 0 = Grade D  
 1 = Grade C  
 2 = Grade B  
 3 = Grade A

● **Axial Non-uniformity**

Usage: Lets the user know if symbol quality is less than acceptable.  
 Definition: If enabled, drives **Output** if grade is under **Axial Non-uniformity Threshold**.  
 Serial Cmd: <**K890**, output on overall grade, overall grade threshold, cell contrast, cell contrast threshold, cell modulation, cell modulation threshold, fixed pattern damage, fixed pattern damage threshold, **axial non-uniformity**, axial non-uniformity threshold, grid non-uniformity, grid non-uniformity threshold, unused ECC, unused ECC threshold>  
 Default: Disabled  
 Options: 0 = Disabled 1 = Enabled

● **Axial Non-uniformity Threshold**

Usage: Sets the threshold for driving the output.  
 Serial Cmd: <**K890**, output on overall grade, overall grade threshold, cell contrast, cell contrast threshold, cell modulation, cell modulation threshold, fixed pattern damage, fixed pattern damage threshold, axial non-uniformity, **axial non-uniformity threshold**, grid non-uniformity, grid non-uniformity threshold, unused ECC, unused ECC threshold>  
 Definition: Conforms to ISO/IEC 29158 symbol quality grading (A,B,C,D).  
 Default: Grade B  
 Options: 0 = Grade D  
 1 = Grade C  
 2 = Grade B  
 3 = Grade A

● **Grid Non-uniformity**

Usage: Lets the user know if symbol quality is less than acceptable.  
 Definition: If enabled, drives **Output** if grade is under **Grid Non-uniformity Threshold**.  
 Serial Cmd: <**K890**, output on overall grade, overall grade threshold, cell contrast, cell contrast threshold, cell modulation, cell modulation threshold, fixed pattern damage, fixed pattern damage threshold, axial non-uniformity, axial non-uniformity threshold, **grid non-uniformity**, grid non-uniformity threshold, unused ECC, unused ECC threshold>  
 Default: Disabled  
 Options: 0 = Disabled 1 = Enabled

### ● Grid Non-uniformity Threshold

Usage:	Sets the threshold for driving the output.	
Definition:	Conforms to ISO/IEC 29158 symbol quality grading (A,B,C,D).	
Serial Cmd:	< <b>K890</b> , output on overall grade, overall grade threshold, cell contrast, cell contrast threshold, cell modulation, cell modulation threshold, fixed pattern damage, fixed pattern damage threshold, axial non-uniformity, axial non-uniformity threshold, grid non-uniformity, <b>grid non-uniformity threshold</b> , unused ECC, unused ECC threshold>	
Default:	Grade B	
Options:	0 = Grade D	
	1 = Grade C	
	2 = Grade B	
	3 = Grade A	

### ● Unused ECC

Usage:	Lets the user know if symbol quality is less than acceptable.	
Definition:	If enabled, drives <b>Output</b> if grade is under <b>Unused ECC Threshold</b> .	
Serial Cmd:	< <b>K890</b> , output on overall grade, overall grade threshold, cell contrast, cell contrast threshold, cell modulation, cell modulation threshold, fixed pattern damage, fixed pattern damage threshold, axial non-uniformity, axial non-uniformity threshold, grid non-uniformity, grid non-uniformity threshold, <b>unused ECC</b> , unused ECC threshold>	
Default:	Disabled	
Options:	0 = Disabled	1 = Enabled

### ● Unused ECC Threshold

Usage:	Sets the threshold for driving the output.	
Definition:	Conforms to ISO/IEC 29158 symbol quality grading (A,B,C,D).	
Serial Cmd:	< <b>K890</b> , output on overall grade, overall grade threshold, cell contrast, cell contrast threshold, cell modulation, cell modulation threshold, fixed pattern damage, fixed pattern damage threshold, axial non-uniformity, axial non-uniformity threshold, grid non-uniformity, grid non-uniformity threshold, unused ECC, <b>unused ECC threshold</b> >	
Default:	Grade B	
Options:	0 = Grade D	
	1 = Grade C	
	2 = Grade B	
	3 = Grade A	

# H-16 Diagnostics Output 1

---

Serial Cmd: <K790,unused 1,service unit>  
Default: 0  
Options: 0 = Disabled

## H-16-1 Service Unit

When **Diagnostic Warning** is enabled, the **Output On** configuration has no effect. The output will remain active as long as one of the diagnostic warning conditions is met. The output will become inactive once it detects that there are no diagnostic warning conditions.

Definition: Allows the user to set up the output to toggle to active when the service timer has expired. This condition will only be held for one service timer click.

**Note:** This feature cannot be used if the reader is in a **Continuous Read** mode.

Serial Cmd: <K790,unused 1,service unit>  
Default: 0  
Options: 0 = Disabled                      1 = Enabled

# H-17 Other Outputs

## H-17-1 Configurable Output 2

Serial Cmd: <K811,output on,output state,pulse width,output mode>

## H-17-2 Trend Analysis Output 2

Serial Cmd: <K781,trend analysis mode,trigger evaluation period,number to output on>

## H-17-3 ISO/IEC 16022 Symbol Quality Output 2

Serial Cmd: <K801,output on symbol contrast,symbol contrast threshold,output on print growth,print growth threshold,output on axial non-uniformity,axial non-uniformity threshold,output on UEC,UEC threshold>

## H-17-4 ISO/IEC 15415 Symbol Quality Output 2

Serial Cmd: <K871, output on overall grade, overall grade threshold, symbol contrast, symbol contrast threshold, modulation, modulation threshold, reflectance margin, reflectance margin threshold, fixed pattern damage, fixed pattern damage threshold, axial non-uniformity, axial non-uniformity threshold, grid non-uniformity, grid non-uniformity threshold, unused ECC, unused ECC threshold>

### H-17-5 ISO/IEC 15416 Symbol Quality Output 2

Serial Cmd: <K881, output on overall grade, overall grade threshold, edge determination, edge determination threshold, decode, decode threshold, contrast, contrast threshold, min reflectance, min reflectance threshold, min edge contrast, min edge contrast threshold, modulation, modulation threshold, defects, defects threshold, decodability, decodability threshold, quiet Zone, quiet zone threshold >

### H-17-6 ISO/IEC 29158 Symbol Quality Output 2

Serial Cmd: <K891, output on overall grade, overall grade threshold, cell contrast, cell contrast threshold, cell modulation, cell modulation threshold, fixed pattern damage, fixed pattern damage threshold, axial non-uniformity, axial non-uniformity threshold, grid non-uniformity, grid non-uniformity threshold, unused ECC, unused ECC threshold>

### H-17-7 Diagnostics Output 2

Serial Cmd: <K791,unused 1,service unit>

### H-17-8 Configurable Output 3

Serial Cmd: <K812,output on,output state,pulse width,output mode>

## Output On Output 3

Usage:	This option provides discrete signalling to host software to control external devices such as PLCs and relays. It is useful for routing, sorting, and preventing mis-packaging and mis-routing.
Definition:	Sets the discrete output functions for specific user-selected conditions. Allows the user to determine when an output (or outputs) will be activated.
Serial Cmd:	< <b>K812</b> , <i>output on,output state,pulse width,output mode</i> >
Default:	Mismatch or No-Read
Options:	0 = Mismatch or No-Read 1 = Match (or Good Read) 2 = Mismatch 3 = No-Read 4 = Trend Analysis 5 = Symbol Quality 6 = Diagnostic Warning 7 = In Read Cycle 8 = Use as External Illumination Strobe

### ● Use as External Illumination Strobe

Definition:	Asserts the external illumination strobe output during image capture.
-------------	---

## H-17-9 Trend Analysis Output 3

Serial Cmd:	< <b>K782</b> , <i>trend analysis mode,trigger evaluation period,number to output on</i> >
-------------	--

## H-17-10 ISO/IEC 16022 Symbol Quality Output 3

Serial Cmd:	< <b>K802</b> , <i>output on symbol contrast,symbol contrast threshold,output on print growth,print growth threshold,output on axial non-uniformity,axial non-uniformity threshold,output on UEC,UEC threshold</i> >
-------------	--

## H-17-11 ISO/IEC 15415 Symbol Quality Output 3

Serial Cmd:	< <b>K872</b> , <i>output on overall grade, overall grade threshold, symbol contrast, symbol contrast threshold, modulation, modulation threshold, reflectance margin, reflectance margin threshold, fixed pattern damage, fixed pattern damage threshold, axial non-uniformity, axial non-uniformity threshold, grid non-uniformity, grid non-uniformity threshold, unused ECC, unused ECC threshold</i> >
-------------	---

### H-17-12 ISO/IEC 15416 Symbol Quality Output 3

Serial Cmd: <K882, output on overall grade, overall grade threshold, edge determination, edge determination threshold, decode, decode threshold, contrast, contrast threshold, min reflectance, min reflectance threshold, min edge contrast, min edge contrast threshold, modulation, modulation threshold, defects, defects threshold, decodability, decodability threshold, quiet Zone, quiet zone threshold >

### H-17-13 ISO/IEC 29158 Symbol Quality Output 3

Serial Cmd: <K892, output on overall grade, overall grade threshold, cell contrast, cell contrast threshold, cell modulation, cell modulation threshold, fixed pattern damage, fixed pattern damage threshold, axial non-uniformity, axial non-uniformity threshold, grid non-uniformity, grid non-uniformity threshold, unused ECC, unused ECC threshold>

### H-17-14 Diagnostics Output 3

Serial Cmd: <K792,unused 1,service unit>



# H-18 Power On/Reset Counts

---

- **Note:** **Power On/Reset Counts** is a read-only command.

## Power-On

---

Serial Cmd: <K406,**power-on**,resets,*power-on saves*,*power-on flash saves*>

**Power-On** uses a 16-bit counter that increments each time the reader is powered-on.

## Resets

---

Serial Cmd: <K406,*power-on*,**resets**,*power-on saves*,*power-on flash saves*>

**Resets** uses a 16-bit counter that increments each time the reader is reset. This value is reset at power-on.

## Power-On Saves

---

Serial Cmd: <K406,*power-on*,resets,**power-on saves**,*power-on flash saves*>

**Power-On Saves** uses a 16-bit counter that increments each time an reader setting is saved for power-on with a <Z> command.

## Power-On Flash Saves

---

Serial Cmd: <K406,*power-on*,resets,*power-on saves*,**power-on flash saves**>

**Power-On Flash Saves** uses a 16-bit counter that increments each time an reader setting is saved to the customer parameter section of flash memory with a <Zc> command.

# H-19 Time Since Reset

---

- **Note:** **Time Since Reset** is a read-only command.

## Hours

---

Serial Cmd: <**K407,hours,minutes**>  
Default: 16-bit counter (0 to 65535)

**Hours** uses a 16-bit counter that increments every 60 minutes.

## Minutes

---

Serial Cmd: <**K407,hours,minutes**>  
Default: 16-bit counter (0 to 60)

**Minutes** uses a 16-bit counter that increments every 60 seconds.

- **Note:** Time counts are reset at power-on, but not with an <**A**> or <**Z**> command.

# H-20 Service Message

---

When **Service Message** is enabled, a message of up to 10 ASCII characters is sent whenever the system detects that the service timer's limit has been reached. The service timer is reset at power-on, meaning that the service timer's limit is the amount of time since last reset. Service timer increments can be set in seconds or minutes.

Serial Cmd: <**K409**,*status*,*service message*,*threshold*,*resolution*>  
 Default: 0  
 Options: 0 = Disabled                      1 = Enabled

## Service Message

---

Serial Cmd: <**K409**,*status*,**service message**,*threshold*,*resolution*>  
 Default: SERVICE  
 Options: An ASCII string between 1 and 10 characters.

## Threshold

---

Serial Cmd: <**K409**,*status*,*service message*,**threshold**,*resolution*>  
 Default: 300 (5 minutes)  
 Options: 1 to 65535

## Resolution

---

Serial Cmd: <**K409**,*status*,*service message*,*threshold*,**resolution**>  
 Default: Seconds  
 Options: 0 = Seconds                      1 = Minutes

## H-21 User-Assigned Name

---

- Definition: **User-Assigned Name** allows you to enter any string of ASCII characters to help you identify your reader. The user-assigned name is saved at power-on and custom defaults, and is stored as a “sticky” parameter so it cannot be defaulted without a **<Zrdall>** or **<K412d>** command.
- Serial Cmd: **<K412,user-assigned name>**
- Options: ASCII string, up to 19 characters

# H-22 Output Object Info

## H-22-1 Output Frame Number

*Serial Cmd:* <K734,output frame number,output coordinates>

*Default:* Disabled

*Options:* 0 = Disabled 1 = Enabled

### Disabled

When **Output Frame Number** is set to **Disabled**, the frame number is not output as part of the symbol data.

### Enabled

When **Output Frame Number** is set to **Enabled**, the number of the frame in which the symbol was first decoded is attached to the symbol output information. The output format is “Fnnn”, where “nnn” is a 3-digit decimal value from 0 to 255. The frame number rolls over to 0 once it passes 255.

If this feature is enabled, the frame information will follow the symbol data, and it will precede any symbol quality data (if symbol quality settings are enabled—see **Symbol Quality Separator**). The symbol quality separator is located between the end of the already-formatted data and the “F” that precedes the frame number.

## H-22-2 Output Coordinates

*Serial Cmd:* <K734,output frame number,output coordinates>

*Default:* Disabled

*Options:* 0 = Disabled 1 = Enabled

### Disabled

When **Output Coordinates** is set to **Disabled**, the coordinates are not output as part of the symbol data.

### Enabled

When **Output Coordinates** is set to **Enabled**, the four sets of object coordinates for the first successfully decoded symbol are attached to the symbol data output in the following format:

“(nnn,mmm)”, where “nnn” is a 3-digit X-coordinate and “mmm” is a 3-digit Y-coordinate. The validation separator is located between the end of the already formatted data and the first coordinate point. The point with the lowest X + Y sum will be output first, followed by the next three points in a clockwise direction.

Example:

(032,040)(287,056)(287,279)(048,271)

## H-23 Database Identifier Output

---

Usage: Useful in keeping track of which database entries read which symbols.  
Serial Cmd: <**K759**,*status*,*separator*>  
Default: 0  
Options: 0 = Disabled                      1 = Enabled

### H-23-1 Output Status

#### Disabled

---

When this command is disabled, no database identifier information will be output.

#### Enabled

---

When this command is enabled, the reader will append a two-digit number and the characters “DB” to the data output following the separator for each symbol decoded using **Configuration Database**. For example, if the separator is an underscore character and the second database entry reads a symbol encoded with “data capture” during the read cycle, the symbol data output will be “data capture\_DB02”. If the database is not active, no identifiers will be attached to output.

### H-23-2 Separator

Usage: The separator character separates the symbol data from the database identifier.  
Serial Cmd: <**K759**,*status*,*separator*>  
Default: <space>  
Options: Any ASCII character.

# H-24 Quality Output

---

## H-24-1 Separator

Definition: The separator character separates quality output data from symbol data.  
Serial Cmd: **<K704,separator,decodes per trigger status>**  
Default: ,  
Options: Any ASCII character.

## H-24-2 Decodes per Trigger Status

Definition: When this feature is enabled, the reader enters a state where it processes frames as configured until the end of a read cycle, with or without a successful symbol decode. When the read cycle ends, the reader outputs any decoded symbol data along with the decodes per trigger count.  
Serial Cmd: **<K704,separator,decodes per trigger status>**  
Default: 0  
Options: 0 = Disabled                      1 = Enabled

# H-25 Image Push to Host

Definition:	<b>Image Storage Status</b> determines whether or not <b>Image Logging</b> is active. <b>Note:</b> Only images that have been processed by the decoder will be saved. If Image Storage Status and <b>RAM Drive Size in MB</b> in <K764> are switched from <b>Disable</b> to <b>Enable</b> , a cold boot of the reader will be required in order to create the required RAM Drive, and it will take additional time for the reader to re-initialize. Switching from Enable to Disable does not require a cold boot.
Serial Cmd:	<K763, <i>image storage status</i> , <i>stored image type</i> , <i>image storage</i> , <i>image file format</i> , <i>image quality</i> , <i>image scale</i> , <i>file save options</i> >
Default:	Disabled
Options:	0 = Disabled 1 = Enabled

## H-25-1 Stored Image Type

Definition:	<b>Stored Image Type</b> defines what kind of image you want to log in a read cycle.
Serial Cmd:	<K763, <i>image storage status</i> , <b><i>stored image type</i></b> , <i>image storage</i> , <i>image file format</i> , <i>image quality</i> , <i>image scale</i> , <i>file save options</i> >
Default:	No Read
Options:	1 = Good Read 2 = No Read 3 = Good Read + No Read 4 = Match 8 = Mismatch 12 = Match + Mismatch 15 = Good Read + No Read + Match + Mismatch

## H-25-2 Image Storage

Definition:	<b>Image Storage</b> defines which image will be stored within a read cycle. <ul style="list-style-type: none"> <li>• <b>Good Read/Match/Mismatch:</b> First qualified image or all qualified images.</li> <li>• <b>No Read:</b> First image or all images that have an IP report.</li> </ul>
Serial Cmd:	<K763, <i>image storage status</i> , <i>stored image type</i> , <b><i>image storage</i></b> , <i>image file format</i> , <i>image quality</i> , <i>image scale</i> , <i>file save options</i> >
Default:	First Image in a Read Cycle
Options:	0 = First Image in a Read Cycle 1 = All Images in a Read Cycle

## H-25-3 Image File Format

Definition:	<b>Image File Format</b> defines the image format you want to use.
Serial Cmd:	<K763, <i>image storage status</i> , <i>stored image type</i> , <i>image storage</i> , <b><i>image file format</i></b> , <i>image quality</i> , <i>image scale</i> , <i>file save options</i> >
Default:	PNG
Options:	0 = PNG 1 = JPG



## H-25-4 Image Quality

Definition:	<b>Image Quality</b> defines the amount of image compression you want the image to have.
Serial Cmd:	< <b>K763</b> , <i>image storage status</i> , <i>stored image type</i> , <i>image storage</i> , <i>image file format</i> , <b>image quality</b> , <i>image scale</i> , <i>file save options</i> >
Default:	90
Options:	1 to 100

## H-25-5 Image Scale

Definition:	<b>Image Scale</b> defines the size you want the image to be.
Serial Cmd:	< <b>K763</b> , <i>image storage status</i> , <i>stored image type</i> , <i>image storage</i> , <i>image file format</i> , <i>image quality</i> , <b>image scale</b> , <i>file save options</i> >
Default:	Full
Options:	0 = Full 1 = 1/4th 2 = 1/8th

## H-25-6 File Save Options

Definition:	<b>File Save Options</b> determines which files you want to save.
Serial Cmd:	< <b>K763</b> , <i>image storage status</i> , <i>stored image type</i> , <i>image storage</i> , <i>image file format</i> , <i>image quality</i> , <i>image scale</i> , <b>file save options</b> >
Default:	Image
Options:	1 = Image 2 = Read Cycle Report 3 = Image + Read Cycle Report

# H-26 Image Push to Host Detailed Setup

## H-26-1 Image Storage Location

Definition:	<p>Defines where the saved image is going to be stored.</p> <p><b>Note:</b> When saving images to <b>RAM</b>, the system is limited to the actual RAM space available in the system. The number of images that can be saved depends on the <b>Max RAM Drive Size</b>. The actual system path is <b>/imagesd0/Images/</b>. When saving images to <b>FTP</b>, the path is <b>&lt;last 6 digits of device's MAC Address&gt;_Images/</b> on the host FTP director. Note that the FTP server needs to grant the user with create directory rights as the system will need to create a directory on the FTP server to store all uploaded images.</p> <p><b>File save scheme:</b> The image file will be posted with its system reset count, followed by its read cycle i.d., followed by its image i.d., followed by its stored image type defined in <b>&lt;K763&gt;</b>, as follows:</p> <p>&lt;last 6 digits of device's MAC Address&gt;_&lt;system total reset count&gt;_&lt;read cycle id&gt;_&lt;image id&gt;_&lt;save image type&gt;.{png, jpg}</p> <p>&lt;last 6 digits of device's MAC Address&gt;_&lt;system total reset count&gt;_&lt;read cycle id&gt;_&lt;image id&gt;_readreport.xml</p>
Serial Cmd:	<b>&lt;K764,image storage location,FTP host info,transfer optimization,RAM drive size in MB,save image until,action at image storage limit&gt;</b>
Default:	RAM
Options:	0 = RAM 1 = FTP

## H-26-2 FTP Host Info

Definition:	<p><b>mscan pass@192.168.188.1:21</b> signifies a the user with <b>mscan</b> at <b>192.168.188.1</b> FTP server on port <b>21</b> with <b>pass</b> as the FTP login password.</p> <p><b>Note:</b> If port is not defined with the FTP server address, it will default to port 21.</p>
Serial Cmd:	<b>&lt;K764,image storage location,FTP host info,transfer optimization,RAM drive size in MB,save image until,action at image storage limit&gt;</b>
Default:	"user pass@xxx.xxx.xxx.xxx:21"
Options:	Maximum 255 characters including the characters "[", "@", and ":".

## H-26-3 Transfer Optimization

Definition:	<b>Transfer Optimization</b> defines how the image is going to be stored in triggered captured modes.
Serial Cmd:	<b>&lt;K764,image storage location,FTP host info,transfer optimization,RAM drive size in MB,save image until,action at image storage limit&gt;</b>
Default:	Speed
Options:	0 = Speed (Lossy) 1 = Accuracy (Lossless)

## Speed (Lossy)

Images will be saved when possible. Some images may be dropped.

**SOR** = Start of Read Cycle

**EOR** = End of Read Cycle

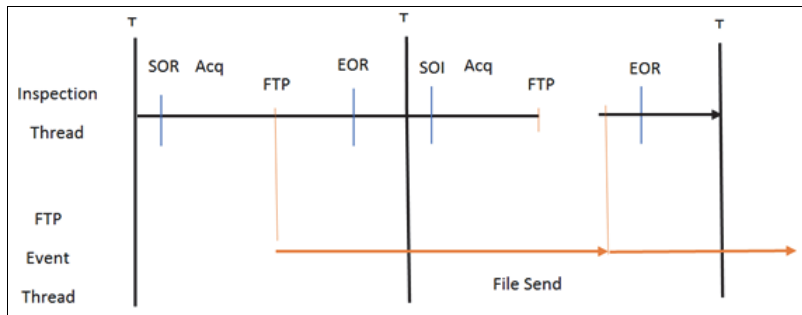

## Accuracy (Lossless)

Every image in read cycle is transferred. The read cycle may be delayed due to image saving since each transfer will need to be finished before the end of the read cycle.

**SOR** = Start of Read Cycle

**EOR** = End of Read Cycle

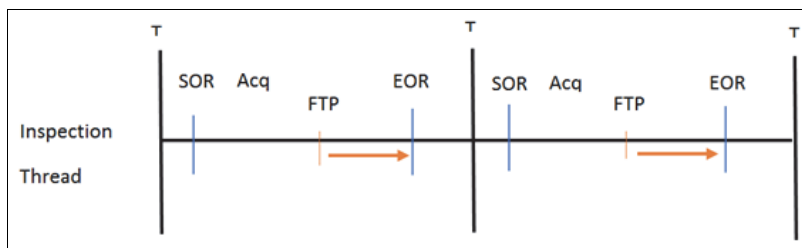

H

### H-26-4 RAM Drive Size in MB

**Definition:** This defines the maximum RAM Drive size on the system. It is also limited to the memory available on the system and affects the max. rapid image count in **<K241>** since the onboard memory may be taken up by the RAM Drive. Images may not be saved if the RAM Drive is not large enough to store all the images in the current read cycle and if **Image Storage Location** is set to **FTP** with **Image Save Mode** set to **Speed**. If Image Storage Location is set to **FTP** with Image Save Mode set to **Accuracy**, all images in the read cycle will be transferred to the FTP host but the read cycle may be delayed.

**Serial Cmd:** **<K764,image storage location,FTP host info,transfer optimization,RAM drive size in MB,save image until,action at image storage limit>**

**Default:** 20

**Options:** 1 to 50

- **Note:** The number of images that can be save in the RAM drive vary depending on model, RAM drive size setting, image file format.

The following is a list of the number of images to be saved when the **Image File Format** is **PNG** and, the **Image Scale** is **Full**.

Resolution	No. of images to be saved	
	default: 20MB	Max.: 50MB
0.3 Mpix	57	143
1.2 Mpix	16	42
5 Mpix	4	10

## H-26-5 Save Image Until

- Definition: This defines how long the image will be stored in the system when the **Image Storage Location** is **RAM**.  
If set to **New Read Cycle**, the saved image will be erased upon entering the next read cycle.  
If set to **System Reset**, the saved image will be erased upon the next system reset.
- Serial Cmd: <**K764**,*image storage location,FTP host info,transfer optimization,RAM drive size in MB,save image until,action at image storage limit*>
- Default: New Read Cycle
- Options: 1 = New Read Cycle  
2 = System Reset

## H-26-6 Action at Image Storage Limit

- Definition: This defines what to do when **Action at Storage Full** is reached and when images are saved on **RAM**. When this setting is set to **Erase Oldest First**, the oldest images in the current read cycle will be erased.
- Serial Cmd: <**K764**,*image storage location,FTP host info,transfer optimization,RAM drive size in MB,save image until,action at image storage limit*>
- Default: Stop
- Options: 0 = Stop  
1 = Erase Oldest First



# Symbol Quality

This section describes parameters that, when enabled, will output detailed symbol quality evaluations.

---

I-1	Symbol Quality Serial Commands	I-2
I-2	Overview of Symbol Quality	I-3
I-3	Symbol Quality Separator/Output Mode	I-4
I-4	ISO/IEC 16022 Symbol Quality Output	I-6
I-5	Omron Microscan Symbol Quality Output	I-8
I-6	ISO/IEC 15415 Symbol Quality Output	I-10
I-7	ISO/IEC 15416 Symbol Quality Output	I-13
I-8	ISO/IEC 29158 Symbol Quality Output	I-17

# I-1 Symbol Quality Serial Commands

---

Symbol Quality Separator / Output Mode	< <b>K708</b> ,symbol quality separator, output mode>
ISO/IEC 16022 Symbol Quality Output	< <b>K709</b> ,symbol contrast,print growth,axial non-uniformity, unused ECC>
Omron Microscan Symbol Quality Output	< <b>K710</b> ,percent cell damage,total read time,capture time,locate time,decode time,pixels per element,ECC level,matrix size,quiet zone,symbol angle>
ISO/IEC 15415 Symbol Quality Output	< <b>K725</b> , aperture, overall, contrast, modulation, reflectance margin, fixed pattern damage, axial nonuniformity, grid nonuniformity, unused ECC>
ISO/IEC 15416 Symbol Quality Output	< <b>K726</b> , aperture, overall, edge determination, decode, contrast, minimum reflectance, minimum edge contrast, modulation, defects, decodability, quiet zone>
ISO/IEC 29158 Symbol Quality Output	< <b>K727</b> , overall, cell contrast, cell modulation, fixed pattern damage, axial nonuniformity, grid nonuniformity, unused ECC>

## I-2 Overview of Symbol Quality

MicroHAWK supports the following standards.

ISO code pint quality grading	Supported code
ISO/IEC 15415	DataMatrix (ECC200, GS1)
	QR Code *1
	Micro QR
ISO/IEC TR 29158	DataMatrix (ECC200, GS1)
ISO/IEC 15416	Code 128/GS1-12
	UPC/EAN(JAN)
	ITF
	Code 39
	Code 93
	Codabar
ISO/IEC 16022 *2	DataMatrix (ECC200, GS1)

**(1) QR Code unique grading, VID/FID, are not supported.**

**(2) The evaluation standard of ISO/IEC 16022 is presently integrated to ISO/IEC 15415.**

Information about symbol quality and timing can be appended to symbol data by enabling specific evaluation parameters. The order in which these values are appended corresponds to the order in ISO/IEC 16022 Parameters, Omron Microscan Grading Parameters, ISO/IEC 15415 Parameters, ISO/IEC 15416 Parameters, and ISO/IEC 29158 Parameters.

Symbol Quality parameters are separated into ISO/IEC 16022 Symbol Quality Output, Omron Microscan Symbol Quality Output, ISO/IEC 15415 Symbol Quality Output, ISO/IEC 15416 Symbol Quality Output, and ISO/IEC 29158 Symbol Quality Output.

**Total Read Time, Symbol Quality Separator, and Output Mode** are common parameters.

## I-3 Symbol Quality Separator/Output Mode

---

**Symbol Quality Separator** applies to all Symbol Quality groups: ISO/IEC 16022 Symbol Quality Output, ISO/IEC 15415 Symbol Quality Output, ISO/IEC 15416 Symbol Quality Output, ISO/IEC 29158 Symbol Quality Output, and Omron Microscan Symbol Quality Output.

### I-3-1 Symbol Quality Separator

- Definition:* Inserts a separator between each enabled field of the symbol quality output.
- Serial Cmd:* **<K708, symbol quality separator, output mode>**
- Default:* **<SP>** (space character)
- Options:* Any ASCII character.



## I-3-2 Output Mode

- **Note:** **Output Mode** applies to ISO/IEC 16022 symbol quality parameters, ISO/IEC 15415 symbol quality parameters, ISO/IEC 15416 symbol quality parameters, and ISO/IEC 29158 symbol quality parameters.

*Definition:* Output Mode specifies how the output parameters, if enabled, are formatted.

*Serial Cmd:* <K708,symbol quality separator,output mode>

*Default:* **Grade**

*Options:* **0 = Grade**                      1 = Value                      2 = Score

### Grade

---

If in **Grade Mode**, a grade (A,B,C,D,F) is appended to the symbol data.

### Value

---

If in **Value Mode**, the calculated value for the given parameter is appended to the symbol data.

### Score

---

If in **Score Mode**, a percentage of passing lines for that parameter is appended to the symbol data.



### I-4-3 Axial Non-Uniformity (Data Matrix Only)

**Definition:** Axial non-uniformity is a measure of how much the sampling point spacing differs from one axis to another, namely  $AN = \text{abs}(XAVG - YAVG) / ((XAVG + YAVG)/2)$  where  $\text{abs}()$  yields the absolute value. If a symbology has more than two major axes, then AN is computed for those two average spacings which differ the most. (ANSI) axial non-uniformity grading is defined this way:

A (4.0) if  $AN < .06$

B (2.0) if  $AN < .08$

C (2.0) if  $AN < .10$

D (1.0) if  $AN < .12$

F (0.0) if  $AN > .12$

If enabled, the axial non-uniformity is appended to the symbol data according the **ISO/IEC 16022 Symbol Quality Output Mode** setting.

**Serial Cmd:** <K709,symbol contrast,print growth,axial non-uniformity,UEC>

**Default:** Disabled

**Options:** 0 = Disabled 1 = Enabled

### I-4-4 Unused Error Correction (Data Matrix Only)

**Definition:** The correction capacity of Reed-Solomon decoding is expressed in the equation:  $e + 2d < d - p$ , where  $e$  is the number of erasures,  $d$  is the number of error correction code words, and  $p$  is the number of code words reserved for error detection.

A (4.0) if  $UEC > .62$

B (3.0) if  $UEC > .50$

C (2.0) if  $UEC > .37$

D (1.0) if  $UEC > .25$

F (0.0) if  $UEC < .25$

If enabled, the UEC is appended to the symbol data according to the **ISO/IEC 16022 Symbol Quality Output Mode** setting.

**Serial Cmd:** <K709,symbol contrast,print growth,axial non-uniformity,UEC>

**Default:** Disabled

**Options:** 0 = Disabled 1 = Enabled

# I-5 Omron Microscan Symbol Quality Output

## I-5-1 Percent Cell Damage (Data Matrix Only)

<i>Definition:</i>	When this feature is enabled, the cell damage percentage is appended to data output.	
<i>Serial Cmd:</i>	< <b>K710,percent cell damage,total read time,capture time,locate time,decode time,pixels per element,ECC level,matrix size,quiet zone,symbol angle</b> >	
<i>Default:</i>	<b>Disabled</b>	
<i>Options:</i>	<b>0 = Disabled</b>	1 = Enabled

## I-5-2 Total Read Time

<i>Definition:</i>	The time that transpires between the image capture and the output of the decoded data, including locate time. When enabled, the total read time is appended to the symbol data.	
<i>Serial Cmd:</i>	< <b>K710,percent cell damage,total read time,capture time,locate time,decode time,pixels per element,ECC level,matrix size,quiet zone,symbol angle</b> >	
<i>Default:</i>	<b>Disabled</b>	
<i>Options:</i>	<b>0 = Disabled</b>	1 = Enabled

## I-5-3 Capture Time

<i>Definition:</i>	Capture time (in milliseconds) is a fixed “overhead” that includes the time of capture and transfer of the image. When enabled, the capture time is appended to the symbol data.	
<i>Serial Cmd:</i>	< <b>K710,percent cell damage,total read time,capture time,locate time,decode time,pixels per element,ECC level,matrix size,quiet zone,symbol angle</b> >	
<i>Default:</i>	<b>Disabled</b>	
<i>Options:</i>	<b>0 = Disabled</b>	1 = Enabled

## I-5-4 Locate Time

<i>Definition:</i>	The time in milliseconds from the start of image processing until the symbol has been located and is ready to be decoded. When enabled, the locate time is appended to the symbol data.	
<i>Serial Cmd:</i>	< <b>K710,percent cell damage,total read time,capture time,locate time,decode time,pixels per element,ECC level,matrix size,quiet zone,symbol angle</b> >	
<i>Default:</i>	<b>Disabled</b>	
<i>Options:</i>	<b>0 = Disabled</b>	1 = Enabled

## I-5-5 Decode Time

<i>Definition:</i>	The time in milliseconds required to decode a symbol. When enabled, the decode time is appended to the symbol data.	
<i>Serial Cmd:</i>	< <b>K710,percent cell damage,total read time,capture time,locate time,decode time,pixels per element,ECC level,matrix size,quiet zone,symbol angle</b> >	
<i>Default:</i>	<b>Disabled</b>	
<i>Options:</i>	<b>0 = Disabled</b>	1 = Enabled

### I-5-6 Pixel Per Element (Data Matrix Only)

<i>Definition:</i>	The number of pixels for each element, either dark or light for both <b>x</b> and <b>y</b> directions. When enabled, the pixels per element value is appended to the symbol data.	
<i>Serial Cmd:</i>	< <b>K710</b> ,percent cell damage,total read time,capture time,locate time,decode time, <b>pixels per element</b> ,ECC level,matrix size,quiet zone,symbol angle>	
<i>Default:</i>	<b>Disabled</b>	
<i>Options:</i>	<b>0 = Disabled</b>	1 = Enabled

### I-5-7 Error Correction Level (Data Matrix Only)

<i>Definition:</i>	Outputs the Data Matrix ECC level. When enabled, the ECC level is appended to the symbol data.	
<i>Serial Cmd:</i>	< <b>K710</b> ,percent cell damage,total read time,capture time,locate time,decode time, <b>pixels per element</b> , <b>ECC level</b> ,matrix size,quiet zone,symbol angle>	
<i>Default:</i>	<b>Disabled</b>	
<i>Options:</i>	<b>0 = Disabled</b>	1 = Enabled

### I-5-8 Matrix Size (Data Matrix Only)

<i>Definition:</i>	Defines the symbol matrix size, in number of pixels in both the <b>x</b> and <b>y</b> axis. When enabled, the matrix size value is appended to the symbol data.	
<i>Serial Cmd:</i>	< <b>K710</b> ,percent cell damage,total read time,capture time,locate time,decode time, <b>pixels per element</b> ,ECC level, <b>matrix size</b> ,quiet zone,symbol angle>	
<i>Default:</i>	<b>Disabled</b>	
<i>Options:</i>	<b>0 = Disabled</b>	1 = Enabled

### I-5-9 Quiet Zone (Data Matrix Only)

<i>Definition:</i>	When this feature is enabled, the size of the quiet zone is evaluated and a PASS or FAIL message is appended to the symbol data.	
<i>Serial Cmd:</i>	< <b>K710</b> ,percent cell damage,total read time,capture time,locate time,decode time, <b>pixels per element</b> ,ECC level,matrix size, <b>quiet zone</b> ,symbol angle>	
<i>Default:</i>	<b>Disabled</b>	
<i>Options:</i>	<b>0 = Disabled</b>	1 = Enabled

### I-5-10 Symbol Angle (Data Matrix Only)

<i>Definition:</i>	When this feature is enabled, the symbol orientation is appended to data output as a degree value representing the angle of the Data Matrix symbol's L-shaped finder pattern relative to the reader.	
<i>Serial Cmd:</i>	< <b>K710</b> ,percent cell damage,total read time,capture time,locate time,decode time, <b>pixels per element</b> ,ECC level,matrix size,quiet zone, <b>symbol angle</b> >	
<i>Default:</i>	<b>Disabled</b>	
<i>Options:</i>	<b>0 = Disabled</b>	1 = Enabled



## I-6-4 Modulation

<i>Definition:</i>	Modulation is calculated in accordance with the ISO 15415 specification. The Modulation grading is defined as follows. A (4.0) if $MOD \geq 0.50$ B (3.0) if $MOD \geq 0.40$ C (2.0) if $MOD \geq 0.30$ D (1.0) if $MOD \geq 0.20$ F (0.0) if $MOD < 0.20$ When enabled, the Modulation is attached to the symbol output data as a value.	
<i>Serial Cmd:</i>	<K725, aperture, overall, contrast, <b>modulation</b> , reflectance margin, fixed pattern damage, axial non-uniformity, grid non-uniformity, unused ECC>	
<i>Default:</i>	<b>Disabled</b>	
<i>Options:</i>	<b>0 = Disabled</b>	1 = Enabled

## I-6-5 Reflectance Margin

<i>Definition:</i>	Reflectance Margin is calculated in accordance with the ISO 15415 specification. When enabled, the Reflectance Margin is attached to the symbol output data as a value.	
<i>Serial Cmd:</i>	<K725, aperture, overall, contrast, modulation, <b>reflectance margin</b> , fixed pattern damage, axial non-uniformity, grid non-uniformity, unused ECC>	
<i>Default:</i>	<b>Disabled</b>	
<i>Options:</i>	<b>0 = Disabled</b>	1 = Enabled

## I-6-6 Fixed Pattern Damage

<i>Definition:</i>	Fixed Pattern Damage is calculated in accordance with the ISO 15415 specification. When enabled, the Fixed Pattern Damage is attached to the symbol output data as a value.	
<i>Serial Cmd:</i>	<K725, aperture, overall, contrast, modulation, reflectance margin, <b>fixed pattern damage</b> , axial non-uniformity, grid non-uniformity, unused ECC>	
<i>Default:</i>	<b>Disabled</b>	
<i>Options:</i>	<b>0 = Disabled</b>	1 = Enabled

## I-6-7 Axial Non-Uniformity

<i>Definition:</i>	Axial Non-Uniformity is calculated in accordance with the ISO 15415 specification. The Axial Non-Uniformity grading is defined as follows. A (4.0) if $AN \leq 0.06$ B (3.0) if $AN \leq 0.08$ C (2.0) if $AN \leq 0.10$ D (1.0) if $AN \leq 0.12$ F (0.0) if $AN > 0.12$ When enabled, the Axial Non-Uniformity is attached to the symbol output data as a value.	
<i>Serial Cmd:</i>	<K725, aperture, overall, contrast, modulation, reflectance margin, fixed pattern damage, <b>axial non-uniformity</b> , grid non-uniformity, unused ECC>	
<i>Default:</i>	<b>Disabled</b>	
<i>Options:</i>	<b>0 = Disabled</b>	1 = Enabled





# I-7 ISO/IEC 15416 Symbol Quality Output

## Symbol Quality Parameters for Barcodes Specified by ISO/IEC 15416

### Supported Symbologies:

- Code 128/GS1-128
- UPC-A/UPC-E/EAN-13/EAN-8
- Interleaved 2 of 5/ITF-14
- Code 39
- Code 93
- Codabar

Minimum Resolution: 4.0 Pixels Per Element

### I-7-1 Aperture

*Definition:* The size of aperture to use for grading configured as a percentage of the nominal narrow element width for the symbol under evaluation. For example, if you have a 13 mil UPC symbol and you wish to grade using a 6 mil aperture you would configure the aperture to 46% ( $6/13 = 0.46$ ).

*Serial Cmd:* <**K726**, **aperture**, overall, edge determination, decode, contrast, minimum reflectance, minimum edge contrast, modulation, defects, decodability, quiet zone>

*Default:* 40%

*Options:* Any number between 0 to 100%

### I-7-2 Overall

*Definition:* Overall is calculated in accordance with the ISO 15416 specification. The overall grade is the average of the individual scan grades applied to the symbol. The individual scan grades are the lowest individual parameter grade seen during the individual scan. These individual scan grades are not available for output. When enabled, the Overall is attached to the symbol output data as a value.

*Serial Cmd:* <**K726**, aperture, **overall**, edge determination, decode, contrast, minimum reflectance, minimum edge contrast, modulation, defects, decodability, quiet zone>

*Default:* **Disabled**

*Options:* **0 = Disabled**                      1 = Enabled

### I-7-3 Edge Determination

*Definition:* Edge Determination is calculated and graded for each scan and provided for the overall grade calculation in accordance with the ISO 15416 specification. The parameter grade and value provided for output is an average value for each measured scan over the entire symbol. When enabled, the Edge Determination is attached to the symbol output data as a value.

*Serial Cmd:* <**K726**, aperture, overall, **edge determination**, decode, contrast, minimum reflectance, minimum edge contrast, modulation, defects, decodability, quiet zone>

*Default:* **Disabled**

*Options:* **0 = Disabled**                      1 = Enabled



## I-7-8 Modulation

*Definition:* Modulation is calculated and graded for each scan and provided for the overall grade calculation in accordance with the ISO 15416 specification. The parameter grade and value provided for output is an average value for each measured scan over the entire symbol.  
When enabled, the Modulation is attached to the symbol output data as a value.

*Serial Cmd:* <**K726**, aperture, overall, edge determination, decode, contrast, minimum reflectance, minimum edge contrast, **modulation**, defects, decodability, quiet zone>

*Default:* **Disabled**

*Options:* **0 = Disabled** 1 = Enabled

## I-7-9 Defects

*Definition:* Defects are calculated and graded for each scan and provided for the overall grade calculation in accordance with the ISO 15416 specification. The parameter grade and value provided for output is an average value for each measured scan over the entire symbol.  
When enabled, the Defects are attached to the symbol output data as a value.

*Serial Cmd:* <**K726**, aperture, overall, edge determination, decode, contrast, minimum reflectance, minimum edge contrast, modulation, **defects**, decodability, quiet zone>

*Default:* **Disabled**

*Options:* **0 = Disabled** 1 = Enabled

## I-7-10 Decodability

*Definition:* Decodability is calculated and graded for each scan and provided for the overall grade calculation in accordance with the ISO 15416 specification. The parameter grade and value provided for output is an average value for each measured scan over the entire symbol.  
When enabled, the Decodability is attached to the symbol output data as a value.

*Serial Cmd:* <**K726**, aperture, overall, edge determination, decode, contrast, minimum reflectance, minimum edge contrast, modulation, defects, **decodability**, quiet zone>

*Default:* **Disabled**

*Options:* **0 = Disabled** 1 = Enabled

## I-7-11 Quiet Zone

*Definition:* Quiet Zone is not an individually processed parameter within the ISO 15416 specification, but it is evaluated as a part of the ISO graded decode parameters feeding into the overall grade. Quiet Zone is provided here as average scan result where a passing scan receives an A/4.0 grade and a fail receives an F/0.0.  
When enabled, the Quiet Zone is attached to the symbol output data as a value.

*Serial Cmd:* <**K726**, aperture, overall, edge determination, decode, contrast, minimum reflectance, minimum edge contrast, modulation, defects, decodability, **quiet zone**>

*Default:* **Disabled**

*Options:* **0 = Disabled** 1 = Enabled

## I-7-12 Grading Report

<VAL4>: Responds with a text report that summarized the grading of ISO/IEC15416.

This command will return the evaluation results, in a format similar to the one shown below.

15416 Validation Report			GRADE
ISO/IEC	Overall	= 0	F
15416:	Edge Determination	= 0	F
	Decode	= 100	A
	Contrast	= 35	D
	Min Reflectance	= 100	A
	Min Edge Contrast	= 0	F
	Modulation	= 0	F
	Defects	= 100	F
	Decodability	= 1	F
	Quize Zone	= 100	F
	Aperture	= 40 %	A
SYMBOL			
DATA:	code128		
TYPE:	Code128		





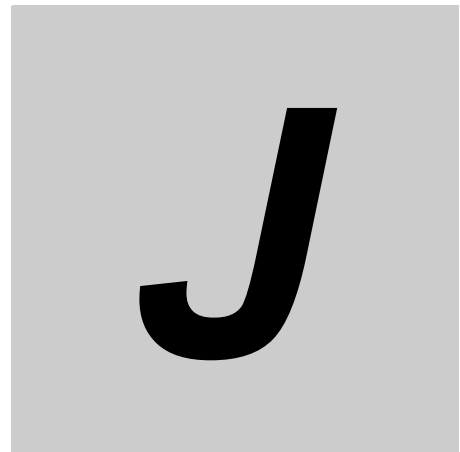

# Matchcode

This section explains the matchcode output functions and the master symbol database setup.

---

<b>J-1 Matchcode Serial Commands</b> .....	<b>J-2</b>
<b>J-2 Overview of Matchcode</b> .....	<b>J-3</b>
<b>J-3 Matchcode Type</b> .....	<b>J-4</b>
<b>J-4 Sequence Step Interval.</b> .....	<b>J-8</b>
<b>J-5 Match Replace</b> .....	<b>J-9</b>
<b>J-6 Mismatch Replace.</b> .....	<b>J-10</b>
<b>J-7 New Master Pin</b> .....	<b>J-11</b>

## J-1 Matchcode Serial Commands

---

Matchcode	<K223,matchcode type, sequential matching, match start position, match length, wildcard character, sequence on No-Read, sequence on mismatch>
Number of Master Symbols	<K224,number of master symbols>
New Master Pin	<K225,status>
Sequence Step Interval	<K228,sequence step interval>
Master Symbol Data	<K231,index, master symbol data>
Match Replace	<K735,status, match replacement string>
Mismatch Replace	<K736,status, mismatch replacement string>



## J-2 Overview of Matchcode

---

- Definition:* **Matchcode** allows the user to store master symbol data in the reader's memory, compare that data against other symbol data, and define how symbol data and/or discrete signal output will be directed. A master symbol database can be set up for up to 10 master symbols. **Note: Matchcode** will function with multiple symbols; however, if **Matchcode Type** is set to **Sequential** or if **Triggering Mode** is set to **Continuous Read 1 Output**, the reader will behave as if **Number of Symbols** were set to 1, regardless of the user-defined configuration.
- Usage:* Matchcode is used in applications to sort, route, or verify data based on matching the specific symbol in a variety of ways as defined in this section. For example, a manufacturer might sort a product based on dates that are embedded in the symbol.

### Steps for Entering and Using Master Symbols

---

- 1** Set **Triggering Mode** to **External** or **Serial**.
- 2** Choose the method of symbol comparison that fits your application.
- 3** Define the output you want to achieve with your matchcode setup:
  - (a) **Symbol data output**
  - (b) **Discrete output**
- 4** Select the number of master symbols you want to create.
- 5** Decide which way you want to enter your master symbol(s):
  - (a) **Send a serial command with symbol data in the form of <M231, master symbol#, data>.**
  - (b) **Send a <G> (Read Next Symbol as Master Symbol) command.**
  - (c) **Enable the New Master Pin command and activate the discrete input to store the next symbol read as the master symbol.**

## J-3 Matchcode Type

- Definition:* Allows the user to choose the way that master symbols will be compared with subsequently read symbols.  
**Note:** First set **Triggering Mode** to **External** or **Serial**.
- Serial Cmd:* <**K223**,*matchcode type*,*sequential matching*,*match start position*,*match length*,*wild card character*,*sequence on No-Read*,*sequence on mismatch*>
- Default:* **Disabled**
- Options:* **0 = Disabled**  
 1 = Enabled  
 2 = Wild Card  
 3 = Sequential
- Disabled:* Has no effect on operations.
- Enabled:* Instructs the reader to compare symbols or portions of symbols with the master symbol.
- Wild Card:* Allows the user to enter user-defined wild card characters in the master symbol.
- Sequential:* Instructs the reader to sequence after each match (numeric only) and compare symbols or portions of symbols for sequential numbers.  
**Note:** If **Matchcode Type** is set to **Sequential**, the reader will behave as if **Number of Symbols** were set to **1**, regardless of the user-defined configuration.

### J-3-1 Sequential Matching

- Usage:* Useful in tracking product serial numbers that increment or decrement sequentially.
- Definition:* With Sequential enabled, Sequential Matching determines if a count is in ascending (incremental) or descending (decremental) order.
- Serial Cmd:* <**K223**,*matchcode type*,**sequential matching**,*match start position*,*match length*,*wild card character*,*sequence on No-Read*,*sequence on mismatch*>
- Default:* **Increment**
- Options:* **0 = Increment**                      1 = Decrement

## J-3-2 Match Start Position

- Usage:** **Match Start Position** is useful in defining specific portions of a symbol for comparison. For example, if a symbol contains a part number, manufacturing date, and lot code info, but you are only interested in the part number information, you can set the reader to sort only the part number and ignore the other characters.
- Definition:** **Match Start Position** determines the portions of symbols that will be matched by defining the first character in the symbol (from left to right) that will be compared with those of the master symbol, when **Matchcode Type** is set to **Enabled** or **Sequential**.
- Function:** For example, if **Match Start Position** is set to **3**, the first 2 characters read in the symbol will be ignored and only the 3rd and subsequent characters to the right will be compared, up to the number of characters specified by **Match Length**.
- Serial Cmd:** *<K223,matchcode type,sequential matching,match start position,match length,wild card character,sequence on No-Read,sequence on mismatch>*
- Default:** 0
- Options:** 0 to 3000

- **Note:** **Match Start Position** must be set to 1 or greater to enable this feature. A 0 setting will disable this feature.

## J-3-3 Match Length

- Usage:** *Example:* If **Match Length** is set to **6** in a 10-character symbol, and **Match Start Position** is set to **2**, only the 2nd through 7th characters (from left to right) will be compared.
- Definition:** Defines the length of the character string that will be compared with that of the master symbol when **Match Start Position** is set to 1 or greater. When **Match Start Position** is set to 0, no comparison will occur.
- Serial Cmd:** *<K223,matchcode type,sequential matching,match start position,match length,wild card character,sequence on No-Read,sequence on mismatch>*
- Default:** 1
- Options:** 1 to 3000

## J-3-4 Wild Card Character

- Usage:** *Example:* With **Wild Card Character** defined as the default asterisk, defining **CR\*34** as the master symbol will result in matches for CR134 and CR234, but not CR2345. Entering **URGENT\*\*** as your master symbol will result in matches for URGENT, URGENT1, and URGENT12 but not for URGENT123. This means any wild cards appended to the master symbol data will result in matches of symbols in variable lengths up to the master symbol lengths but not over. However, wild cards in the beginning or center of a symbol (e.g., UR\*\*NT) do not allow for variable symbol lengths.
- Definition:** Wild Card Character allows a user to define a wild card character as part of the master symbol.
- Serial Cmd:** *<K223,matchcode type,sequential matching,match start position,match length,wild card character,sequence on No-Read,sequence on mismatch>*
- Default:** \* (asterisk)
- Options:** Any ASCII character.



As an example of **Sequence on Mismatch Enabled**, consider the following decodes:

<i>Master Symbol</i>	<i>Decoded Symbol</i>	<i>Master Symbol after Decode</i>
001	001	002
002	002	003
003	abc	004 (sequenced on mismatch)
004	004	005
005	def	006 (sequenced on mismatch)
006	ghi	007 (sequenced on mismatch)
007	007	008

As an example of **Sequence on Mismatch Disabled**, consider the following decodes:

<i>Master Symbol</i>	<i>Decoded Symbol</i>	<i>Master Symbol after Decode</i>
001	001	002
002	002	003
003	abc	004 (sequenced because of previous match)
004	004	005
005	def	006 (sequenced because of previous match)
006	ghi	006 (not sequenced)
006	006	007

# J-4 Sequence Step Interval

---

- Usage:* Useful in applications in which it is desirable to count by intervals other than 1.
- Definition:* Sequencing in Matchcode operations can occur in steps from 1 to 32,768.  
Sequencing performs like a mechanical counter by displaying positive integers and a specific number of digits after roll-overs. For example, 000 – 3 = 997 (not -3) and 999 + 3 = 002 (not 1002).
- Serial Cmd:* <**K228,sequence step interval**>
- Default:* 1
- Options:* Any number from 1 to 32768

*Example:* If **Sequence Step** is set to **3** and **Sequential Matching** is set to **Increment**:

<i>Master Symbol</i>	<i>Decoded Symbol</i>	<i>Master Symbol after Decode</i>
003	001	003
003	002	003
003	003	006
006	004	006
006	005	006
006	006	009

## J-5 Match Replace

---

<i>Usage:</i>	Provides a convenient shortcut for applications that need to output a predefined text string whenever a symbol matches a master symbol.	
<i>Definition:</i>	Outputs a user-defined data string whenever a match occurs and <b>Matchcode</b> is enabled.	
<i>Serial Cmd:</i>	< <b>K735</b> , <i>status</i> , <i>replacement string</i> >	
<i>Default:</i>	<b>Disabled</b>	
<i>Options:</i>	<b>0 = Disabled</b>	1 = Enabled

### J-5-1 Replacement String

<i>Definition:</i>	User-defined data string that, when enabled, replaces symbol data whenever a match occurs.
<i>Serial Cmd:</i>	< <b>K735</b> , <i>status</i> , <b>replacement string</b> >
<i>Default:</i>	<b>MATCH</b>
<i>Options:</i>	An ASCII string up to 64 characters.

## J-6 Mismatch Replace

---

<i>Usage:</i>	Provides a convenient shortcut for applications that need to output a predefined text string whenever a symbol does not match a master symbol.
<i>Definition:</i>	Outputs a user-defined data string whenever a mismatch occurs and <b>Matchcode</b> is enabled.
<i>Serial Cmd:</i>	< <b>K736</b> , <i>status</i> , <i>replacement string</i> >
<i>Default:</i>	<b>Disabled</b>
<i>Options:</i>	<b>0 = Disabled</b> 1 = Enabled

### J-6-1 Replacement String

<i>Definition:</i>	User-defined data string that, when enabled, replaces symbol data whenever a mismatch occurs.
<i>Serial Cmd:</i>	< <b>K736</b> , <i>status</i> , <i>replacement string</i> >
<i>Default:</i>	<b>MISMATCH</b>
<i>Options:</i>	An ASCII string up to 64 characters.



## J-7 New Master Pin

<i>Definition:</i>	If <b>Matchcode</b> and <b>New Master Pin</b> are enabled and the new master pin is momentarily activated (must be active for a minimum of 10 ms) master symbol information will be loaded into the database based on the next read cycle that achieves a Good Read, starting with <b>Index 1</b> .	
	<b>Note:</b> For the MicroHAWK, Input 1 (pin 3) is Default and Input 2 (pin 4) is New Master.	
<i>Serial Cmd:</i>	<K225,status>	
<i>Default:</i>	<b>Disabled</b>	
<i>Options:</i>	<b>0 = Disabled</b>	1 = Enabled

### J-7-1 New Master Load Status

<i>Definition:</i>	The new master status responds with the number of the next master position to be loaded, where 0 represents "idle" or "no master to be loaded."
	<i>Example:</i> If the user has the <b>Number of Master Symbols</b> set to <b>1</b> , and then either sends a <G> or toggles an active <b>New Master Pin</b> , the state will be <b>1</b> , and prior to reading and effectively loading position <b>1</b> , the response to <NEWM> would be <NEWM/1>. Once a symbol has been read and loaded, the status will be cleared: <NEWM/0>.
<i>Serial Cmd:</i>	<NEWM>



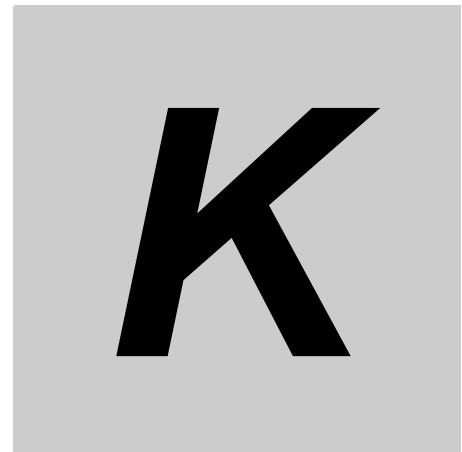

# Camera and IP Setup

---

This section provides adjustment parameters for the physical controls of the camera, image acquisition, database settings, and image diagnostics.

---

<b>K-1 Camera and IP Setup Serial Commands</b> .....	<b>K-2</b>
<b>K-2 Window of Interest</b> .....	<b>K-3</b>
<b>K-3 Pixel Binning</b> .....	<b>K-5</b>
<b>K-4 Camera Settings</b> .....	<b>K-6</b>
<b>K-5 White Balance Settings (Q SXGA Color Only)</b> .....	<b>K-7</b>
<b>K-6 Color Filter</b> .....	<b>K-8</b>
<b>K-7 Focus Setup</b> .....	<b>K-9</b>
<b>K-8 Illumination Brightness</b> .....	<b>K-10</b>
<b>K-9 Morphological Pre-Processing</b> .....	<b>K-12</b>
<b>K-10 Morphological Operation and Operator Size</b> .....	<b>K-13</b>
<b>K-11 Damaged Symbol</b> .....	<b>K-15</b>
<b>K-12 Linear Security Level</b> .....	<b>K-16</b>
<b>K-13 Advanced Decoding Parameters</b> .....	<b>K-16</b>

# K-1 Camera and IP Setup Serial Commands

Window of Interest	<K516,row pointer,column pointer,row depth,column width>
Damaged Symbol	<K519,damaged symbol status>
Focus Setup	<K525,focal distance,distance units,focus mode,no-read limit>
Illumination Brightness	<K536,brightness,light source,fixed light on time,fixed light on delay time>
Camera Settings	<K541,exposure,gain>
Pixel Binning	<K542,pixel binning status>
Color Filter	<K543,color filter>
White Balance	<K544,red gain,green gain,blue gain>
Morphological Pre-Processing	<K550,status>
Morphological Operation	<K551,morphological operation,operator size>
Set License	<K556,license file name,license key>
Linear Security Level	<K560,linear security level>
Fast Linear Mode	<K562,Fast Linear Mode>
Curved 2D	<K563,Curved 2D>
Shift-JIS to UTF-8	<K564,Shift-JIS to UTF-8>
1D Quiet Zone Violation	<K565,1D Quiet Zone Violation>
Scale Image	<K566,Scale Image>
2D Damaged Mode	<K567,2D Damaged Mode>
Attempt Morphology Manipulation	<K568,Attempt Morphology Manipulation>

## K-2 Window of Interest

The active pixel area of the image sensor is called the **Window of Interest (WOI)**. The WOI allows the user to select an area of the field of view in which the desired symbol is located.

The programmable window of interest increases decode speed, improves threshold, and makes it easy to select specific symbols from among several in the field of view. The user provides the upper-left pixel location and the size of the window in rows and columns to define the Window of Interest.

K

### K-2-1 Window of Interest by Serial Command

The figure shows where to locate the start position of the row and column pointers and how to measure the column depth and row width dimensions.

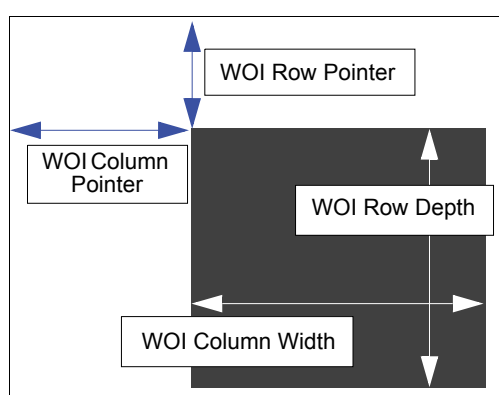

#### Row Pointer

- Definition:** Defines the row position of the upper-left starting point of the image window.
- Serial Cmd:** <K516,row pointer,column pointer,row depth,column width>
- Default:** All models: 0
- Options:** V430-F000  50C QSXGA : 0 to (1944 – row depth)  
 V430-F000  12M SXGA : 0 to (960 – row depth)  
 V430-F   M03M WVGA : 0 to (480 – row depth)

#### Column Pointer

- Definition:** Defines the column position of the upper-left starting point of the image window.
- Serial Cmd:** <K516,row pointer,column pointer,row depth,column width>
- Default:** All models: 0
- Options:** V430-F000  50C QSXGA: 0 to (2592 – column width)  
 V430-F000  12M SXGA: 0 to (1280 – column width)  
 V430-F   M03M WVGA: 0 to (752 – column width)

## Row Depth

---

- Definition:* Defines the size, in rows, of the image window. Maximum value is defined as the maximum row size of the image sensor minus the Row Pointer value.
- Serial Cmd:* <**K516**,row pointer,column pointer,row **depth**,column width>
- Default:* **V430-F000** □ **50C QSXGA: 1944**  
**V430-F000** □ **12M SXGA: 960**  
**V430-F** □□□ **M03M WVGA: 480**
- Options:* **V430-F000** □ **50C QSXGA:** 3 to (1944 – row pointer)  
**V430-F000** □ **12M SXGA:** 3 to (960 – row pointer)  
**V430-F** □□□ **M03M WVGA:** 3 to (480 – row pointer)

## Column Width

---

- Definition:* Defines the size, in columns, of the image window. Maximum value is defined as the maximum column size of the image sensor minus the Column Pointer value.
- Serial Cmd:* <**K516**,row pointer,column pointer,row depth,**column width**>
- Default:* **V430-F000** □ **50C QSXGA: 2592**  
**V430-F000** □ **12M SXGA: 1280**  
**V430-F** □□□ **M03M WVGA: 752**
- Options:* **V430-F000** □ **50C QSXGA:** 8 to (2592 – column pointer)  
**V430-F000** □ **12M SXGA:** 8 to (1280 – column pointer)  
**V430-F** □□□ **M03M WVGA:** 8 to (752 – column pointer)

## Important Notes

---

- The column width value must be a modulus 8 value. Regardless of the column width setting that is configured, the actual column width will be decreased if necessary to a modulus 8 value. For example, a column width value of **639** would actually be **632**. A user query for the value of this setting would still return **639**.
- The column pointer must be an even value. Regardless of the column pointer setting that is configured, the actual column pointer will be decreased if necessary to an even value. For example, a column pointer value of **101** would actually be **100**. A user query for the value of this setting would still return **101**.



## K-4 Camera Settings

**Camera Settings** are typically obtained during the calibration process, and do not necessarily need to be modified directly by the user.

### K-4-1 QSXGA, SXGA, and WVGA

#### ● Exposure

- Usage:* Faster exposures reduce blurring in faster applications.  
Slower exposures are useful in slower applications and lower contrast applications.
- Definition:* This value sets the exposure or integration time (in micro-seconds) for the image sensor pixels. The exposure setting in relation to the speed of the object is critical. If an object is moving rapidly and too long an exposure value is selected, blurring or smearing of the object will occur. As exposure time is decreased the movement of the object becomes less of a factor but, with the duration of light collection by the pixels reduced, the image sensor gain will need to be increased to compensate.
- Serial Cmd:* <K541,exposure,gain>
- Default:* **All versions: 2,500 µs**
- Options:* Any number between 50 – 100,000
- Note:** The Exposure parameter is read-only when the reader is in **Continuous Read Auto Trigger Mode**.

#### ● Gain

- Usage:* Can be used to adjust the brightness of the image.
- Definition:* Sets the gain value for the image sensor and is a percentage value from 0 (lowest gain) to 100% (highest gain). This setting can be configured through auto-calibration. A higher gain value will increase the brightness of the image, but the noise performance of the system will be reduced. Before configuring the gain, the required exposure should be set, and the gain should be configured to optimize the exposure setting.
- Serial Cmd:* <K541,exposure,gain>
- Default:* **QSXGA: 33%**  
**SXGA: 0%**  
**WVGA: 33%**
- Options:* Any number between 0 – 100, representing 0% to 100%

- **Important:** There are 4 levels of Gain in SXGA readers. Each level corresponds to 25 percentage points.
  - Level 1 = 0 to 24%
  - Level 2 = 25 to 49%
  - Level 3 = 50 to 74%
  - Level 4 = 75 to 100%



## K-5 White Balance Settings (QSXGA Color Only)

*Definition:* <K544,red gain,green gain,blue gain>  
*Default:* **Factory-Calibrated**  
*Options:* Any number between 0 – 100

K

### K-5-1 Red Gain

Sets the gain value for the red color channel of the image sensor and is a percentage value from 0% (lowest gain) to 100% (highest gain). The color channel parameters are used to avoid unrealistic colors so that objects that appear white to the human eye are rendered white in the final image. The default value for this parameter is factory-calibrated.

### K-5-2 Green Gain

Sets the gain value for the green color channel of the image sensor and is a percentage value from 0% (lowest gain) to 100% (highest gain). The color channel parameters are used to avoid unrealistic colors so that objects that appear white to the human eye are rendered white in the final image. The default value for this parameter is factory-calibrated.

### K-5-3 Blue Gain

Sets the gain value for the blue color channel of the image sensor and is a percentage value from 0% (lowest gain) to 100% (highest gain). The color channel parameters are used to avoid unrealistic colors so that objects that appear white to the human eye are rendered white in the final image. The default value for this parameter is factory-calibrated.

## K-6 Color Filter

*Definition:* If you are using a 5 megapixel color MicroHAWK V430-F-series, this filter captures an image in color. To process the image for symbol decoding, the image must be filtered or the R, G, and B cells need to be equalized. This can be done by applying one of the filters available or by performing a white balance with the current camera configuration before trying to decode a symbol. This option specifies the filter method that is applied to the RGB color image to produce a monochrome image.

*Usage:* <K543,color filter>

*Default:* **Green Interpolate**

*Options:* 0 = Disabled (Raw, No Filter)  
1 = Enabled  
2 = Horizontal 1D Symbols  
3 = **Green Interpolate**

### K-6-1 Disable

No filter is applied to image. If you are attempting to read symbols with no filter applied, a white balance should be performed first to balance the red, blue, and green cells of the image sensor.

### K-6-2 Enabled (General Purpose)

This is a general purpose filter that is applied to the RGB image to provide a grayscale image that can be used for most applications.

This filter should be used when reading 2D symbols, 1D symbols that are not positioned horizontally in the field of view, or a combination of 1D and 2D symbols.

### K-6-3 Horizontal 1D Symbols

This filter is applied to the RGB image to provide a grayscale image that is specifically designed to provide the best suitable image for a horizontally-positioned 1D symbol.

This filter should be used when reading 1D symbols that are positioned horizontally across the field of view.

### K-6-4 Green Interpolate

This filter is applied to the RGB image to provide a grayscale image for decoding similar to a luminance calculation. Unlike a luminance calculation, Green Interpolate provides an image 1:1 resolution to the input image. This filter provides better omni-directional symbol decode performance. Like Horizontal 1D Symbols, and unlike General Purpose, a white balance is not necessary.

This filter is recommended for most decoding applications that can afford extra processing time.

- **Note:** For high-resolution 1D symbols that are positioned horizontally, the Horizontal 1D Symbols filter is preferable.

# K-7 Focus Setup

## K-7-1 Focal Distance

- Definition:** Provides the focal distance adjustment for the camera.  
Any value outside this range will be rejected.  
If you attempt to set the Focal distance as the out of range value of your model, the parameter will be left as-is.
- Serial Cmd:** <K525,focal distance,distance units,focus mode,no-read limit>
- Default:** 102
- Options:** 25 to 4,000 (mm)  
100 to 4,000 (1/100 inch)

## K-7-2 Distance Units

- Definition:** Defines the measurement unit value of the **Focal Distance** parameter.
- Serial Cmd:** <K525,focal distance,distance units,focus mode,no-read limit>
- Default:** Millimeters
- Options:** 0 = Millimeters  
1 = 1/100 inch

For example, the following are valid configurations to set the Focal Distance to three distances:

Required Focal Distance	Distance Units = mm (0)	Distance Units = 1/100 in. (1)
2 inch, or 50 mm	<K525,50,0>	<K525,200,1>
3 inch, or 76 mm	<K525,76,0>	<K525,300,1>
6 inch, or 152 mm	<K525,152,0>	<K525,600,1>

## K-7-3 Focus Mode

- Definition:** This field set to 1 enables the autofocus mode to be enabled. The read cycle must also be a **Continuous Read** mode or **Continuous Read Auto** (Auto Photometry) mode. Autofocus mode does not apply to triggered read cycles. If the value is set to 0, only the distance value is used.
- Serial Cmd:** <K525,focal distance,distance units,focus mode,no-read limit>
- Default:** No-Read Autofocus
- Options:** 0 = User Value Only  
1 = No-Read Autofocus

## K-7-4 No-Read Limit

- Definition:** This is the number of no-reads that are encountered consecutively in a **Continuous Read** mode to trigger an **Autofocus** pass.
- Serial Cmd:** <K525,focal distance,distance units,focus mode,no-read limit>
- Default:** 5
- Options:** 1 to 255

## K-8 Illumination Brightness

*Definition:* This feature allows you to adjust the brightness of the illumination LEDs. Since the reader has control over the brightness of the illumination, it can provide consistent brightness output between readers through a factory calibration operation. Each of the brightness settings is calibrated to provide the same level of intensity for each reader.

*Serial Cmd:* <K536,brightness,light source,fixed light on time,fixed light on delay time>

*Default:* **High**

*Options:* 0 = Off  
1 = Low  
2 = Medium  
**3 = High**  
4 = Constant  
5 = Extreme

### Constant

When set to **Constant**, the illumination brightness is the same power level as the **High** setting. However, the LEDs will always be on during a read cycle and will only be off between read cycles. This cuts down on perceptible LED flashing.

### Extreme

When set to **Extreme**, illumination brightness enters Power Strobe mode. In this mode, illumination is extremely intense, and can only be activated for a maximum of 1 ms.

## K-8-1 Light Source

*Definition:* The setting allows the user to change the illumination light source.

*Serial Cmd:* <K536,brightness,light source,fixed light on time,fixed light on delay time>

*Default:* **Outer LED Only**

*Options:* 0 = External Strobe  
1 = Inner White LED Only  
2 = Inner Red LED Only  
**3 = Outer LED Only**

### External Strobe

For **Configurable Output 3 (K812)**, **Output On, Use as External Illumination Strobe** to function, **Light Source** must be set to **External Strobe**.

## K-8-2 Fixed Light ON Time

- **Note:** Fixed Light ON Time only functions when **Power Strobe** mode and **External Strobe** are enabled.
- **Note:** Entering **0** will disable Fixed Light ON Time, and will override it to **1 ms** if **Illumination Brightness** is set to **Extreme**.

*Definition:* **Fixed Light ON Time** allows you to control **how long** illumination will be **ON** when the camera captures an image. This command functions along with **Fixed Light ON Delay Time** to allow you to vary the amount of time an object appears in an image capture, assuming the capture environment is dark.

*Serial Cmd:* <K536,brightness,light source,fixed light on time,fixed light on delay time>

*Options:* 0 - 100,000  $\mu$ s

*Default:* **0 (Disabled)**

## K-8-3 Fixed Light ON Delay Time

- **Note:** Fixed Light ON Delay Time only functions when **Power Strobe** mode and **External Strobe** are enabled.

*Definition:* **Fixed Light ON Delay Time** allows you to control **when** illumination will be **ON** during an image capture. This command functions along with **Fixed Light ON Time** to allow you to vary **the time at which** an object appears in an image capture, assuming the capture environment is dark.

**Example of Fixed Light ON Time and Fixed Light ON Delay Time in Power Strobe Mode:**

**Preconditions:** The moving target object will show up 20  $\mu$ s after capture starts. A 100  $\mu$ s exposure will be able to freeze a moving object in the captured image.

**Setup:** Power Strobe with Fixed Light ON Time set to 100  $\mu$ s and Fixed Light ON Delay Time set to 20  $\mu$ s with exposure set to 120  $\mu$ s.

**Example of Fixed Light ON Time and Fixed Light ON Delay Time in External Strobe Mode:**

**Preconditions:** The time delay between the strobe signal on the reader's Output 3 and the moment the external illuminator turns ON is 50  $\mu$ s. A 100  $\mu$ s exposure will be able to freeze a moving object in the captured image.

**Setup:** External Strobe with Fixed Light ON Time set to 50  $\mu$ s and Fixed Light ON Delay Time set to 100  $\mu$ s with exposure set to 150  $\mu$ s.

*Serial Cmd:* <K536,brightness,light source,fixed light on time,fixed light on delay time>

*Options:* 0 - 100,000  $\mu$ s

*Default:* **0**



# K-10 Morphological Operation and Operator Size

K

## K-10-1 Morphological Operation

*Definition:* **Morphological Operation** allows the user to select the method for processing captured images.

*Serial Cmd:* <K551,0,morphological operation,operator size>

*Default:* **Grow Dark**

*Options:* **0 = Grow Dark**  
 1 = Shrink Dark  
 2 = Connect Dark  
 3 = Separate Dark

### Erode (Grow Dark)

**Erode** increases the dark cell size of a symbol. Useful for increasing the dark cell size of a dark-on-light Data Matrix symbol.

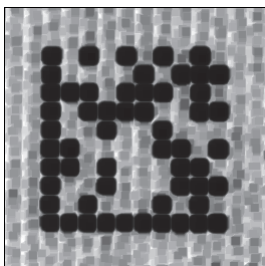

### Dilate (Shrink Dark)

**Dilate** increases the light cell size of a symbol. Useful for increasing the light cell size of a light-on-dark Data Matrix symbol.

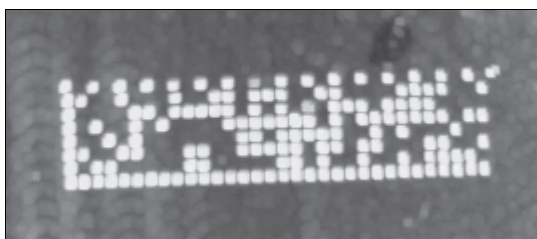

## Open (Connect Dark)

**Open** removes minor light defects of dark cells by performing a **Dilate** function followed by an **Erode** function.

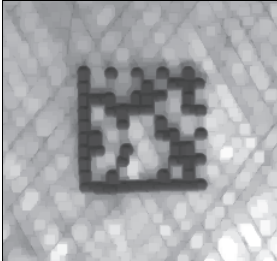

## Close (Separate Dark)

**Close** removed minor dark defects of light cells by performing an **Erode** function followed by a **Dilate** function.

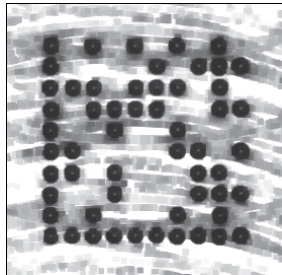

## K-10-2 Operator Size

*Definition:* **Operator Size** determines the size of the area or "pixel neighborhood" (measured in pixels) in which the morphological operation is being performed.

*Serial Cmd:* `<K551,0,morphological operation,operator size>`

*Default:* **Small**

*Options:* **3 = Small (3 pixels by 3 pixels)**

**5 = Medium (5 pixels by 5 pixels)**

**7 = Large (7 pixels by 7 pixels)**



# K-11 Damaged Symbol

---

*Definition:* When **Damaged Symbol** is enabled, the reader will make additional attempts to decode damaged Code 128 and Code 39 symbols. It is effective on symbols with high noise and partial bar missing. Enabling Damaged Symbol may significantly increase decode time.

*Serial Cmd:* <**K519**,*damaged symbol status*>

*Default:* **Disabled**

*Options:* **0 = Disabled**

1 = Enabled

**K**

## K-12 Linear Security Level

---

*Definition:* **Linear Security Level** is intended to prevent misreads. When it is set to a higher level, it requires more scan lines to decode the same result, making it more secure.

*Serial Cmd:* <K560,linear security level>

*Default:* **Aggressive**

*Options:* **0 = Aggressive**

1 = Normal

2 = Secure

## K-13 Advanced Decoding Parameters

---

*Definition:* **Advanced Decoding Parameters** can help you read difficult and damaged symbols, and are optimized for direct part marks (DPM).

**Important:** The following K commands are described in detail in the [Advanced Decoding Parameters](#) section of [Advanced Settings](#).

*Serial Cmd:* <K562,Fast Linear Mode>

<K563,Curved 2D>

<K564,Shift-JIS to UTF-8>

<K565,Linear Quiet Zone Violation>

<K566,Scale Image>

<K567,2D Damaged Mode>

<K568,Attempt Morphology Manipulation>

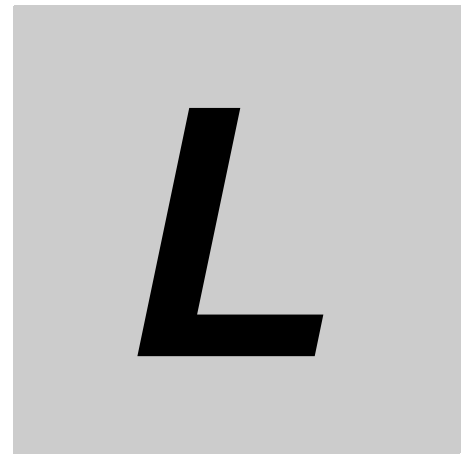

# Configuration Database

---

This section concerns the various capture settings and processing settings that can be used to fine-tune the reader's performance in your application.

---

<b>L-1 Introduction</b>	<b>L-2</b>
<b>L-2 Configuration Database Serial Commands</b>	<b>L-3</b>
<b>L-3 Number of Active Indexes</b>	<b>L-4</b>
<b>L-4 Configuration Database Status</b>	<b>L-5</b>
<b>L-5 Database Mode</b>	<b>L-10</b>
<b>L-6 Save Current Settings to Configuration Database</b>	<b>L-13</b>
<b>L-7 Load Current Settings from Configuration Database</b>	<b>L-14</b>
<b>L-8 Request Selected Index Settings</b>	<b>L-15</b>
<b>L-9 Request All Configuration Database Settings</b>	<b>L-16</b>

# L-1 Introduction

---

For the Configuration Database, the following functions as the bank switching function are possible to achieve.

- Up to ten settings can be held.
- Settable parameters: Exposure, Gain, Focal Distance, Pixel Binning, Window of Interest/Region of Interest, Symbology, Morphology Operator, and Morphology Size.
- Switch command of the database: <K255-,index>
- Automatic switching function of the database: <K252,number of active indexes>

## L-2 Configuration Database Serial Commands

---

Number of Active Indexes	<K252,number of active indexes,sort database>
Configuration Database Status	<K255,index,exposure,gain,focal distance,pixel binning,row pointer,column pointer,row depth,column width,symbology,morphology operator,morphology size>
Save Current Settings to Database	<K255+,index>
Load Current Settings from Database	<K255-,index>
Request Selected Index Settings	<K255?,index>
Request All Database Settings	<K255?>
Database Mode	<K256,switch mode,frame count/time,image process looping,image dimensions>

L

## L-3 Number of Active Indexes

---

*Usage:* Useful for applications that require several different complex reader configurations to be applied sequentially. Multiple database indexes allow you to concatenate configuration profiles, and to perform more complex operations than would be possible with only one set of configuration parameters.

*Definition:* This feature allows you to set the number of database records (groups of settings) that will be used automatically during the read cycle. If **Number of Active Indexes** is set to 0, only the current reader settings will be used, not database entry settings.

*Serial Cmd:* <**K252,number of active indexes,sort database**>

*Default:* **0 (Disabled)**

*Options:* 0 to 10

### L-3-1 Sort Database

*Definition:* **Sort Database** moves the database entry that produced a successful decode to the first position in the list of database entries.

*Serial Cmd:* <**K252,number of active indexes,sort database**>

*Default:* **Disabled**

*Options:* **0 = Disabled**                      1 = Enabled

## L-4 Configuration Database Status

### L-4-1 Index

*Usage:* Useful for applications that require several different complex reader configurations to be applied sequentially. Multiple database indexes allow you to concatenate configuration profiles, and to perform more complex operations than would be possible with only one set of configuration parameters.

*Definition:* Determines the specific database index that will be used.

*Serial Cmd:* <K255,index,exposure,gain,focal distance,pixel binning,row pointer,column pointer,row depth,column width,symbology,morphology operator,morphology size>

*Options:* 1 to 10

### L-4-2 Exposure

*Serial Cmd:* <K255,index,exposure,gain,focal distance,pixel binning,row pointer,column pointer,row depth,column width,symbology,morphology operator,morphology size>

*Default:* 2500

*Options:* 50 to 100,000

- **Note:** The Exposure parameter is read-only when the reader is in **Continuous Read** mode.

### L-4-3 Gain

*Serial Cmd:* <K255,index,exposure,gain,focal distance,pixel binning,row pointer,column pointer,row depth,column width,symbology,morphology operator,morphology size>

*Default:* 0

*Options:* 0 to 100

### L-4-4 Focal Distance

*Definition:* Provides the focal distance adjustment for the camera.

Any value outside this range will be rejected.

If you attempt to set the Focal distance as the out of range value of your model, the parameter will be left as-is.

*Serial Cmd:* <K255,index,exposure,gain,focal distance,pixel binning,row pointer,column pointer,row depth,column width,symbology,morphology operator,morphology size>

*Default:* 102

*Options:* 25 to 4,000 (mm)  
100 to 4,000 (1/100 inch)

### L-4-5 Pixel Binning

*Serial Cmd:* <K255,index,exposure,gain,focal distance,pixel binning,row pointer,column pointer,row depth,column width,symbology,morphology operator,morphology size>

*Default:* Disabled

*Options:* 0 = Disabled                      1 = Enabled

- **Important:** Pixel Binning has no effect when the **Image Dimension** mode is configured as **Region of Interest** in the **Data-base Mode** command. This is because the **Window of Interest** camera settings are determined by the software based on the **Region of Interest** setup. There is no benefit to Pixel Binning to increase processing speed when ROI is configured, because the frame size would need to be increased to make Pixel Binning possible.

## L-4-6 Row Pointer

**Definition:** The image dimension settings can be applied as a Window of Interest or a Region of Interest, depending on the image dimension mode selected in the **Database Mode** command.

**Serial Cmd:** <K255,index,exposure,gain,focal distance,pixel binning,**row pointer**,column pointer,row depth,column width,symbology,morphology operator,morphology size>

**Default:** All models: 0

**Options:** V430-F000  50C QSXGA: 0 to (1944 – row depth)  
 V430-F000  12M SXGA: 0 to (960 – row depth)  
 V430-F  M03M WVGA: 0 to (480 – row depth)

## L-4-7 Column Pointer

**Definition:** The image dimension settings can be applied as a Window of Interest or a Region of Interest, depending on the image dimension mode selected in the **Database Mode** command.

**Serial Cmd:** <K255,index,exposure,gain,focal distance,pixel binning,row pointer,**column pointer**,row depth,column width,symbology,morphology operator,morphology size>

**Default:** All models: 0

**Options:** V430-F000  50C QSXGA: 0 to (2592 – column width)  
 V430-F000  12M SXGA: 0 to (1280 – column width)  
 V430-F  M03M WVGA: 0 to (752 – column width)

## L-4-8 Row Depth

**Definition:** The image dimension settings can be applied as a Window of Interest or a Region of Interest, depending on the image dimension mode selected in the **Database Mode** command.

**Serial Cmd:** <K255,index,exposure,gain,focal distance,pixel binning,row pointer,column pointer,**row depth**,column width,symbology,morphology operator,morphology size>

**Default:** V430-F000  50C QSXGA: 1944  
 V430-F000  12M SXGA: 960  
 V430-F  M03M WVGA: 480

**Options:** V430-F000  50C QSXGA: 3 to (1944 – row pointer)  
 V430-F000  12M SXGA: 3 to (960 – row pointer)  
 V430-F  M03M WVGA: 3 to (480 – row pointer)

## L-4-9 Column Width

**Definition:** The image dimension settings can be applied as a Window of Interest or a Region of Interest, depending on the image dimension mode selected in the **Database Mode** command.

**Serial Cmd:** <K255,index,exposure,gain,focal distance,pixel binning,row pointer,column pointer,row depth,**column width**,symbology,morphology operator,morphology size>

**Default:** V430-F000  50C QSXGA: 2592  
 V430-F000  12M SXGA: 1280  
 V430-F  M03M WVGA: 752

**Options:** V430-F000  50C QSXGA: 8 to (2592 – column pointer)  
 V430-F000  12M SXGA: 8 to (1280 – column pointer)  
 V430-F  M03M WVGA: 8 to (752 – column pointer)



## L-4-10 Symbology

**Definition:** This field allows the user to configure the database to enable specific symbologies for selected database indexes. Symbology-specific parameters must be configured with the appropriate symbology command.

For example, if fixed length Code 128 is required, it must first be set up with the Code 128 command: **<K474>**.

To select a particular symbology, add the number value associated with that symbology.

**Examples:**

If Data Matrix and Code 39 are required, the parameter would be:  $2 + 16 = 18$ .

If I 2/5, BC412, and DataBar Limited are required, the parameter would be:  $128 + 2048 + 16384 = 18560$ .

**Serial Cmd:** **<K255,index,exposure,gain,focal distance,pixel binning,row pointer,column pointer,row depth,column width,symbology,morphology operator,morphology size>**

**Default:** **Disabled**

### Disabled

When **Symbology** is disabled, the database uses the current **Symbology** setup to determine active symbologies.

### Any Symbology (Add 1)

All symbologies *except Pharmacode* are enabled while this database index is being used.

### Data Matrix (Add 2)

If enabled, Data Matrix will be active for this database index.

- **Important:** The ECC level must be configured using the Data Matrix command **<K479>**. If no ECC level has been configured, the reader will not decode Data Matrix symbols.

### QR Code (Add 4)

If enabled, QR Code will be active for this database index.

### Code 128 (Add 8)

If enabled, Code 128 will be active for this database index.

### Code 39 (Add 16)

If enabled, Code 39 will be active for this database index.

### Codabar (Add 32)

If enabled, Codabar will be active for this database index.

### Code 93 (Add 64)

If enabled, Code 93 will be active for this database index.

### Interleaved 2 of 5 (Add 128)

If enabled, Interleaved 2 of 5 will be active for this database index.

## UPC/EAN (Add 256)

---

If enabled, UPC/EAN will be active for this database index.

## PDF417 (Add 512)

---

If enabled, PDF417 will be active for this database index.

## MicroPDF417 (Add 1024)

---

If enabled, MicroPDF417 will be active for this database index.

## BC412 (Add 2048)

---

If enabled, BC412 will be active for this database index.

## Pharmacode (Add 4096)

---

If enabled, Pharmacode will be active for this database index.

## DataBar-14 (Add 8192)

---

If enabled, DataBar-14 will be active for this database index.

- **Important:** If the stacked and non-stacked operation is required, the DataBar-14 command must be configured as follows: **<K482,2>**. If the DataBar-14 status parameter in the **<K482>** command is set to either Disabled or Enabled, the reader will only read non-stacked DataBar-14 symbols.

## DataBar Limited (Add 16384)

---

If enabled, DataBar Limited will be active for this database index.

## DataBar Expanded (Add 32768)

---

If enabled, DataBar Expanded will be active for this database index.

- **Important:** If the stacked and non-stacked operation is required, the DataBar Expanded command must be configured as follows: **<K484,2>**. If the DataBar Expanded status parameter in the **<K484>** command is set to either Disabled or Enabled, the reader will only read non-stacked DataBar Expanded symbols.

## Micro QR Code (Add 65536)

---

If enabled, Micro QR Code will be active for this database index.

## Aztec (Add 131072)

---

If enabled, Aztec will be active for this database index.

## Postal Symbologies (Add 262144)

---

If enabled, Postal Symbologies will be active for this database index.

## L-4-11 Morphology Operator

*Definition:* Specifies the morphology operation (**erode**, **dilate**, **open**, **close**) used to pre-process the WOI.

*Serial Cmd:* <**K255**,*index,exposure,gain,focal distance,pixel binning,row pointer,column pointer,row depth,column width,symbology,morphology operator,morphology size*>

*Default:* **Disabled**

## L-4-12 Morphology Size

*Definition:* Specifies the morphology operator size to apply: **Small (3 x 3)**, **Medium (5 x 5)**, and **Large (7 x 7)**.

*Serial Cmd:* <**K255**,*index,exposure,gain,focal distance,pixel binning,row pointer,column pointer,row depth,column width,symbology,morphology operator,morphology size*>

*Default:* **Small(3 x 3)**

L

## L-5 Database Mode

### L-5-1 Switch Mode

**Definition:** Selects the event that causes the reader to load the next database entry to current, active settings. When **Frame Count/Time** expires and **Image Process Looping** is enabled, the next database entry with modifications to camera settings will be used.

**Note:** The image capture event always occurs when the first database entry is used.

**Note:** The **Switch Mode** setting has no effect on **Rapid Capture Mode**, which always operates in **Number of Image Frames** mode with a frame count of 1.

**Serial Cmd:** <K256,switch mode,frame count/time,image process looping,image dimensions>

**Default:** 1

**Options:** 0 = Time                      1 = Number of Image Frames

#### Time

When **Switch Mode** is set to **Time**, the reader will load the next database entry to current, active settings after a predefined time interval. The timer will start upon use of a database entry. If the timer expires during an image capture event, the timer will not start again until that database entry has been incremented and the new database entry has been loaded to current, active settings.

#### Number of Image Frames

When **Switch Mode** is set to **Number of Image Frames**, the database entry is incremented after the pre-determined number of image capture events has occurred.

### L-5-2 Frame Count/Time

**Definition:** Indicates the **Number of Image Frames** that must be captured or the amount of **Time** that must transpire before the reader will load the next database index entry.

**Serial Cmd:** <K256,switch mode,frame count/time,image process looping,image dimensions>

**Default:** 1 (frames or ms)

**Options:** 1 to 65535

### L-5-3 Image Process Looping

**Usage:** Useful in applications where it is necessary to process a single captured image multiple times using different IP and decode parameters.

**Serial Cmd:** <K256,switch mode,frame count/time,image process looping,image dimensions>

**Default:** Disabled

**Options:** 0 = Disabled                      1 = Enabled

## Disabled

---

When **Image Process Looping** is set to **Disabled**, an image is captured for every database configuration, whether or not any camera settings have been modified.

## Enabled

---

When **Image Process Looping** is set to **Enabled**, the last captured image frame is re-processed with the new IP and decode parameters. If camera settings have not been changed from the last capture event, and when a database configuration is loaded to current, active settings, no new image is captured.

**Note:** An exception to this is the first database index: a new image is always captured when the first database index is used. When a camera setting has been modified from one database setting to the next, a new image is captured. For example, if all database entries contained the same camera setting values but had different IP and decode parameters, an image frame would only be captured when the first database configuration was used.

L

### L-5-4 Image Dimensions

*Definition:* Determines how the image dimension parameters will be implemented.

*Serial Cmd:* <K256,switch mode,frame count/time,image process looping,**image dimensions**>

*Default:* **0**

*Options:* **0 = Window of Interest**      1 = Region of Interest

## Region of Interest (ROI)

When **Image Dimensions** is set to Region of Interest, the database image dimension parameters are *IP and decode settings*, and they determine the region or area of the captured image to be processed.

**ROI** coordinate data is based on the full image size. The **WOI** of the captured image will be configured to cover all the ROI settings in the current, active database entry. In the following example, there are three active database settings, each with a different ROI configuration. Their coordinates are based at point 0,0 of the full scale image. In this example, **DB1** and **DB3** determine the size of the captured image WOI, while **DB2** has no impact. The image WOI is not configurable. It is automatically set up by the database according to the ROI settings.

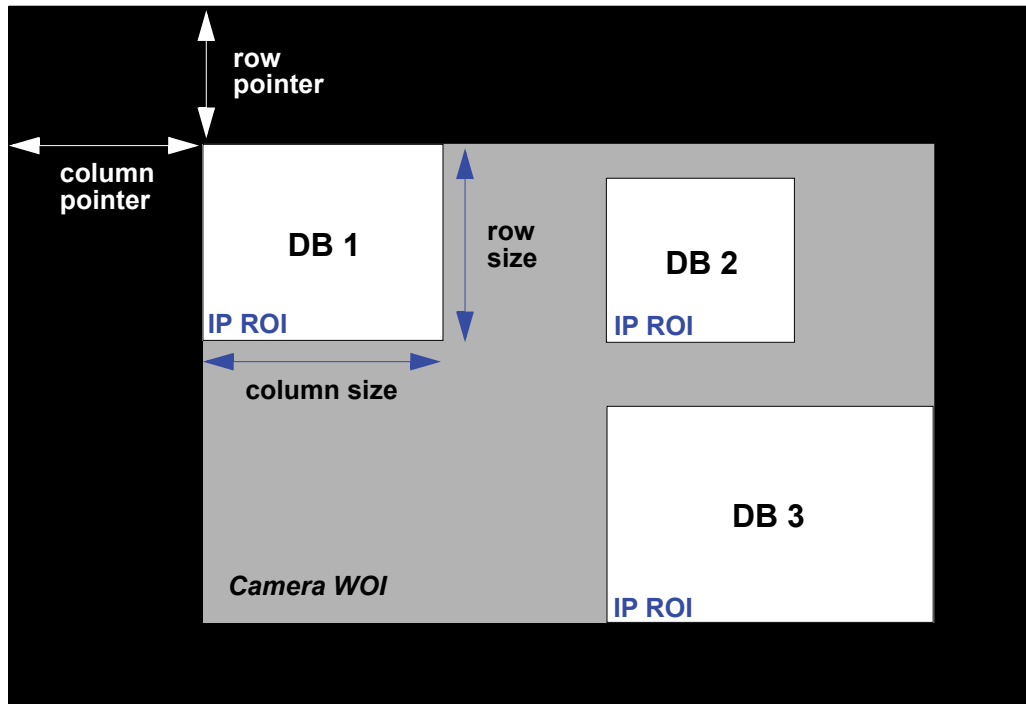

**Full Image Size (SXGA Reader: 1280 x 960; WVGA Reader: 752 x 480)**

- **Note:** Since the **ROI** parameters are not a camera setting, a change in **ROI** parameters from one index to another does *not* indicate an image capture event.

This feature is intended to be used in conjunction with **Image Process Looping**, to allow different regions of a captured image to be processed using different IP and decode settings.

Also, if this feature is used in conjunction with **Output Filtering**, multiple decoded symbols in a captured image frame can be output according to their location in the field of view.

## L-6 Save Current Settings to Configuration Database

---

*Definition:* Allows current, active configuration settings to be saved to a selected database index.

*Serial Cmd:* <K255+,index>

**Example:**

<K255+,5>

This command phrase saves the reader's current, active configuration settings to database index 5.

L

## L-7 Load Current Settings from Configuration Database

---

*Definition:* Allows the configuration settings contained in a selected database index to be loaded to current, active configuration settings.

*Serial Cmd:* <K255-,index>

**Example:**

<K255-,5>

This command phrase loads the configuration settings contained in database index 5 to current, active configuration settings.

### Notes on Symbol Type

---

- The **current** DataBar Expanded status does not change if it is configured as Enabled (Stacked) and the **database** DataBar Expanded status is Enabled.
- The **current** DataBar-14 status does not change if it is configured as Enabled (Stacked) and the **database** DataBar Expanded status is Enabled.
- Data Matrix ECC level is determined by the **current** settings and not by **database** settings. Therefore, the database does not know which ECC level to enable, and has no effect on current Data Matrix ECC settings.



## L-8 Request Selected Index Settings

---

*Definition:* Returns configuration settings for the selected database index.  
*Serial Cmd:* <K255?,index>

**Example:**

<K255?,5>

This command phrase returns the configuration settings for database index 5.

L

## L-9 Request All Configuration Database Settings

---

*Definition:* Returns configuration settings for all indexes in the Configuration Database.

*Serial Cmd:* <K255?>

**Example:**

<K255?>

This command phrase returns the configuration settings for all 10 database indexes.



# Utilities

Utility commands are generally commands that are performed during reader operations to check or determine read rates, or to perform miscellaneous operations on reader hardware. Serial utility commands are not prefaced with a “K” and a numeric code, nor do they require an initialization command (<A> and <Z>). They can be entered from within any terminal program or from **WebLink’s Terminal** window.

---

<b>M-1 Operational Commands</b> .....	<b>M-2</b>
<b>M-2 Read Rate</b> .....	<b>M-4</b>
<b>M-3 Counters</b> .....	<b>M-5</b>
<b>M-4 Device Control</b> .....	<b>M-6</b>
<b>M-5 Master Database</b> .....	<b>M-7</b>
<b>M-6 Firmware</b> .....	<b>M-9</b>
<b>M-7 Default/Reset/Save</b> .....	<b>M-10</b>
<b>M-8 Reader Status Request</b> .....	<b>M-12</b>
<b>M-9 Other Operational Serial Commands</b> .....	<b>M-14</b>

# M-1 Operational Commands

Type	Command	Name
Counter Request/Clear	<q>	No-Reads Per Read Cycle Counter
	<q0>	No-Reads Per Read Cycle Counter Reset
	<\$>	Mismatch Per Read Cycle Counter
	<\$0>	Mismatch Per Read Cycle Counter Reset
	<N>	No-Read Counter
	<O>	No-Read Counter Reset
	<T>	Trigger Counter
	<U>	Trigger Counter Reset
	<V>	Match Code Counter
	<W>	Match Code Counter Reset
	<X>	Mismatch Counter
Firmware Verification	<#>	Request All Part Numbers
	<#a>	Request Application Firmware Part Number
	<#b>	Request Boot Code Firmware Part Number
	<!>	Request All Firmware Checksums
	<!a>	Request Application Firmware Checksum
	<!b>	Request Boot Code Firmware Checksum
Read Rate	<C>	Decodes Per Second Test
	<Cp>	Decode Percent Test
	<J>	Exit Read Rate Tests
Device Control	<a1>	Preface PDF417 Output with Data Attributes
	<L1>	Pulse Programmable Output 1
	<L2>	Pulse Programmable Output 2
Read Cycle Enable/Disable	<L3>	Pulse Programmable Output 3
	<I>	End Current Read Cycle until <H>
	<H>	Enable Read Cycle after <I>
	<I1> <sup>1</sup>	Activate Targeting System
Parameter Reset/Save	<I0> <sup>2</sup>	Deactivate Targeting System
	<A?/1>	Complete Reset when Resets or Save for Power-On Command Has Been Issued
Resets	<A?/0>	Warm Reset if Power-On Command Has Been Issued
	<A>	Software Reset, Current Parameters Retained
	<Ard>	Software Reset, Recall Default Parameters except Communication and Custom Unit Name Parameters
	<Arp>	Software Reset, Recall Power-On Default Parameters
	<Arc>	Software Reset, Recall Customer Default Parameters
Save for Power-On	<Z>	Software Reset, Save Current Settings for Power-On
	<Zc>	Software Reset, Save Current Settings as Customer Default Parameters
	<Zrc>	Software Reset, Recall Customer Default Parameters and Save for Power-On
	<Zrd>	Software Reset, Recall Microscan Default Parameters Except Communication and Custom Unit Name Parameters and Save for Power-On
	<Zrdall>	Software Reset, Recall Microscan Default Parameters Including Communication and Custom Unit Name Parameters and Save for Power-On
Master Database	<G>	Store Next Symbol Read to Database Index 1
	<Gn>	Store Next Symbol Read to Database Index <i>n</i>
	<NEWM>	New Master Load Status
Reader Status	<?>	Reader Status Request

<sup>1</sup><I1> = lowercase 'L', one  
<sup>2</sup><I0> = lowercase 'L', zero

<b>Train/Optimize</b>	<b>&lt;TRAIN&gt;</b>	Initiate Train Operation
	<b>&lt;UNTRAIN&gt;</b>	Initiate Untrain Operation
	<b>&lt;TRAIN?&gt;</b>	Train Status Request
	<b>&lt;OPT&gt;</b>	Initiate Optimize Operation
	<b>&lt;UNOPT&gt;</b>	Initiate Un-Optimize Operation
	<b>&lt;OPT?&gt;</b>	Display Optimize Status
<b>Barcode Configuration</b>	<b>&lt;BCCFG&gt;</b>	Enter Barcode Configuration
<b>Symbol Quality</b>	<b>&lt;VAL3&gt;</b>	ISO/IEC 15415 Grading Report
	<b>&lt;VAL4&gt;</b>	ISO/IEC 15416 Grading Report
	<b>&lt;VAL5&gt;</b>	ISO/IEC 29158 Grading Report



## M-2 Read Rate

---

### M-2-1 Read Rate Serial Utility Commands

#### Enter Decodes/Second Test

---

Sending <C> instructs the reader to transmit the decodes per second and symbol data (if any). The decode rate can vary dramatically due to the angle and location of the symbol in relation to the field of view. This test is very useful in aligning and positioning the reader during setup.

#### Enter Percent Test

---

Sending <Cp> instructs the reader to transmit the percentage of decodes and any decoded symbol data.

#### End Read Rate Test

---

Sending <J> ends both the Percent test and the Decodes/Second test.

# M-3 Counters

**M**

## M-3-1 Counters by Serial Command

### No-Read Counter

Sending <N> displays the total number of No-Reads that have occurred since the last reset.

### No-Read Counter Reset

Sending <O> sets the No-Read Counter to 0.

### Trigger Counter

Sending <T> displays the total number of triggers since the last reset.

### Trigger Counter Reset

Sending <U> sets the trigger counter to 0.

### Good Read/Match Counter (or Good Read Counter)

Sending <V> displays the total number of good reads matching the master symbol, or, if **Master Symbol** is not enabled, the number of good reads since the last reset. This counter is always enabled, but will only work as a match count when **Master Symbol** is enabled. If **Master Symbol** is not enabled, this counter records the number of good reads. This count can be requested at any time.

### Good Read/Match Counter Reset

Sending <W> sets the Match Counter to 0.

### Mismatch Counter

Sending <X> displays the number of decoded symbols since the last reset that do not match the master symbol.

### Mismatch Counter Reset

Sending <Y> sets the Mismatch Counter to 0.

## M-4 Device Control

---

### M-4-1 Device Control by Serial Command

#### Output 1 Pulse

---

Sending <L1> activates the link between Output 1 (+) and Output 1 (-) of the host connector (regardless of Master Symbol or Output 1 status).

#### Output 2 Pulse

---

Sending <L2> activates the link between Output 2 (+) and Output 2 (-) of the host connector (regardless of Master Symbol or Output 2 status).

#### Output 3 Pulse

---

Sending <L3> activates the link between Output 3 (+) and Output 3 (-) of the host connector (regardless of Master Symbol or Output 3 status).

#### Disable Reader

---

Sending <I> will turn the reader OFF, end the current read cycle, and will not allow the reader to enter another read cycle until turned ON. This feature is useful during extended periods of time when no symbols are being decoded, or the reader is being configured. Disabling the reader will not affect any commands that have already been downloaded.

#### Enable Reader

---

Sending <H> will turn the reader ON and allow it to enter read cycles.



# M-5 Master Database

M

## M-5-1 Master Symbol Database Size

**Definition:** **Number of Master Symbols** allows you to select **1 to 10** master symbols for the master symbol database.

**Serial Cmd:** `<K231,master symbol number,master symbol data>`

**Note:** You must follow this command with a save command `<A>` or `<Z>`.

**Default:** 1

**Options:** 1 to 10

- **Caution:** Since the total number of characters available for the master symbol database is **3000**, changes to the **Master Symbol Database Size** will re-allocate the number of characters available for each master symbol and could cause existing master symbols to be deleted (except master symbol #1, unless it also exceeds the size limitation).

The table below specifies the maximum number of characters available to each symbol according the number of master symbols defined, from 1 to 10.

<i>Master Symbol Number</i>	<i>Maximum Characters</i>	<i>Master Symbol Number</i>	<i>Maximum Characters</i>
# 1	3000	# 6	500
# 2	1500	# 7	428
# 3	1000	# 8	375
# 4	750	# 9	333
# 5	600	# 10	300

## M-5-2 Enter Master Symbol Data

**Usage:** Allows you to enter master symbol data for any enabled master symbol index number (1 to 10), provided the total number of characters does not exceed the maximum allowed.

**Serial Cmd:** `<K231,master symbol number,master symbol data>`

**Options:** Enter data for 1 to 10 symbols (any combination of ASCII text up to the maximum allowed).

For example, to enter data for master symbol 9, after making certain that master symbol database size is enabled for 9 or more symbols, send `<K231,9,data>`.

**Important:** The ASCII characters `<`, `>`, and `,` can only be entered as hex values.

**Caution:** If no data is entered, the existing data will be deleted.

## M-5-3 Request Master Symbol Data

**Definition:** Returns master symbol data for any enabled master symbols from 1 to 10. For example, to request master symbol # 5, enter `<K231?,5>`. The reader transmits master symbol # 5 data in brackets in the following format: `<5/>`. If no master symbol data is available, the output will be: `<5/>`.

**Serial Cmd:** `<K231?,master symbol number>`

**Caution:** Be sure to add the `?` or you will delete the master symbol.

**Note:** This command returns the number of master symbols if no number is included.

## M-5-4 Request All Master Symbol Data

**Definition:** This command will return master symbol data for all symbols enabled (up to 10).

**Serial Cmd:** `<K231?>`

### M-5-5 Read Next Symbol as Master Symbol

*Definition:* After you've set the size in the database, you can order the reader to read the next symbol as the master symbol for any given master symbol number.

*Serial Cmd:* **<Gmaster symbol number>**

To store the next symbol decoded as master symbol # 1, send:

**<G>** or **<G1>**.

To store the next symbol decoded as the master symbol for any other master symbol database number, send:

**<Gmaster symbol number [1-10]>**.

For example, **<G5>** will cause the next symbol read to be entered as master symbol # 5.

### M-5-6 Request New Master Status

*Usage:* Informs the user when a new master symbol is pending and which position it is in.

*Definition:* Returns the position in the master symbol database that will be loaded on the next read.

*Serial Cmd:* **<NEWM>**

The reader returns: **<NEWM/next master to load>**

Once a symbol has been read and loaded, the status will be cleared and the response will be **<NEWM/0>**.

(See also **New Master Pin** in **Matchcode**.)

### M-5-7 Delete Master Symbol Data

*Definition:* You can directly delete the master symbol data by serial command.

*Serial Cmd:* **<K231,master symbol number,>**

To delete a master symbol, enter the database number and a comma, but leave the data field empty. For example, to delete master symbol # 5, send the following: **<K231,5,>**. The command is entered with a blank master symbol data field, which tells the reader to delete the selected master symbol from the database.

# M-6 Firmware

## M-6-1 Firmware Update

Application code versions are specific to your reader. Consult with your sales representative before downloading application code. If needed, an application code file will be sent to you.

### Firmware Verification

M

#### ● Request Part Number by Serial Command

- When you send `<#>` (a request for all product part numbers), the reader returns:
- `<#b/BOOT_P/N><#a/APP_P/N><#p/PROFILE_P/N>`.
- When you send `<#a>` (a request for the application code part number), the reader returns:
- `<#a/APP_P/N>`.
- When you send `<#b>` (a request for the boot code part number), the reader returns:
- `<#b/BOOT_P/N>`.
- When you send `<#p>` (a request for profile module part numbers), the reader returns:
- `<#p/PROFILE_P/N>`.

#### ● Request Checksum by Serial Command

- When you send `<!>` (a request for all available firmware checksums), the reader returns:
- `<!b/BOOT_CHECKSUM><!a/APP_CHECKSUM><!p/PROFILE_CHECKSUM>`
- When you send `<!a>` (a request for the application code checksum), the reader returns:
- `<!a/APP_CHECKSUM>`
- When you send `<!b>` (a request for the boot code checksum), the reader returns:
- `<!b/BOOT_CHECKSUM>`
- When you send `<!p>` (a request for profile module checksum), the reader returns:
- `<!p/PROFILE_CHECKSUM>`

## M-7 Default/Reset/Save

Understanding and controlling your reader's active, saved, and default settings is critical to its successful operation.

	<i>Function</i>	<i>Serial Cmd</i>
<b>Resets (not saved for power-on)</b>	Reset	<A>
	Reset and Recall Microscan Defaults	<Ard>
	Reset and Recall Power-On Parameters	<Arp>
	Reset and Recall Customer Default Parameters	<Arc>
<b>Saved for Power-on</b>	Save Current Settings for Power-On	<Z>
	Save Current Settings as Customer Default Parameters for Power-On	<Zc>
	Recall Microscan Default Parameters and Save for Power-On	<Zrd>
	Recall Customer Default Parameters and Save for Power-On	<Zrc>

### M-7-1 Resets

Resets (“A” commands) affect only the current settings (active memory) and are not saved for power-on.

### M-7-2 Saved for Power-On

Power-on parameters (“Z” commands) are saved to NOVRAM and recalled and loaded into current parameters when power is cycled to the reader or the <Arp> command is issued.

### M-7-3 Defaults

Defaults are Omron Microscan firmware settings or saved customer settings that can be recalled, either by software or hardware reset.

### M-7-4 Customer Default Parameters

Customer default parameters (saved by <Zc>) are the same set of parameters as power-on parameters but are saved in a different, isolated section of NOVRAM. This allows a user essentially to create a backup set of parameters that can be recalled in the event that the current parameters or power-on parameters have been accidentally changed or are no longer desired.

It is important to note that a hardware default does not affect customer default parameters. For example, a user that has inadvertently changed communication settings and saved them with a <Z> command, may not know the correct settings or have the capability to communicate within those settings. By first doing a hardware default to restore the known Omron Microscan defaults, the user can then recall the previous customer saved settings with an <Arc> or <Zrc> command.

### M-7-5 Omron Microscan Default Parameters

Omron Microscan default parameters are contained in the firmware and cannot be changed.

## Software Defaults

---

Omron Microscan default parameters can be recalled (loaded into current settings) with **<Ard>** command or recalled and saved for power-on with the **<Zrd>** command.

## Hardware Default

---

If a software default and reset is not possible, it may be necessary to reset the reader by shorting (connecting) specific pins. This procedure has the same effect as the **<Zrdall>** software command.

- **Important:** For this reset to occur, this command must be executed within 60 seconds of a power-on or a reset.

**1** Apply power to the reader.

**2** Locate Pin 3 (Default) and Pin 7 (Ground) on the connector. (Access depends on wiring configuration. May require an accessory cable).

- **Caution:** Be certain that the correct pins are located. Connecting the wrong pins could cause serious damage to the unit.

**3** Momentarily connect the wires (or pins).

**4** Within 3 seconds, disconnect and then reconnect the two wires again.

# M-8 Reader Status Requests

## M-8-1 <?> Status Byte

The reader responds to a status request <?> with a two character hex value, such as <?/22>. To determine status:

- 1** Look up the binary conversion in the table below.  
For example, the first hex **2** would be **0 0 1 0** in binary, as read from binary digits **3** through **0**; the second hex **2** is also **0 0 1 0** as read from binary digits **7** through **4**.
- 2** Next, enter your binary values from the table below in the “Binary” column next to the appropriate bit.

Hex Value	Binary Bit Digits			
	7	6	5	4
	3	2	1	0
0	0	0	0	0
1	0	0	0	1
2	0	0	1	0
3	0	0	1	1
4	0	1	0	0
5	0	1	0	1
6	0	1	1	0
7	0	1	1	1
8	1	0	0	0
9	1	0	0	1
A	1	0	1	0
B	1	0	1	1
C	1	1	0	0
D	1	1	0	1
E	1	1	1	0
F	1	1	1	1

Bit	Binary	Reader Status
0	0	Command error detected
1	1	Command received
2	0	Communication error detected
3	0	Flash sector unprotect failure
4	0	Host port buffer overflow
5	1	Reader is in a read cycle

- 3** Under “Binary,” interpret **1s** as true and **0s** as not true. For example, bit 1 has a **1** in the “Binary” column, indicating “Command Received”. Bit 5 is also a **1**, indicating that the “Reader is in a read cycle”.

## M-8-2 <K?> All Status Request

This is the fastest way to learn the reader’s current configuration. Sending this request will return the current settings of all commands, starting with the lowest K command value and ending with the highest K command value.

## M-8-3 <K??> All Descriptor Status Request

This request will return all current descriptors for every K command, starting with the lowest K command value and ending with the highest K command value.

#### **M-8-4 <K?#> All Range Status Request**

This request will return the current settings of all commands within the user-defined range, starting with the lowest user-defined K command value and ending with the highest user-defined K command value.

#### **M-8-5 <Knnn?> Single Status Request**

This request will return the value of the variables associated with the requested K command. The request of a single entry of a database command cannot exceed the number of database slots for the specific command.

#### **M-8-6 <Knnn??> Single Descriptor Status Request**

This request returns the basic functional description of all fields in the requested K command.

#### **M-8-7 <Knnn?#> Single Range Status Request**

This request will return the value range and storage type description of all fields in the requested K command.

#### **M-8-8 <Knnn?\*> Display Command Wildcard**

This request will return the individual K command status, description, and range for each parameter.

## M-9 Other Operational Serial Commands

The following serial utility commands can be entered from **Terminal** or a PLC:

### M-9-1 Train and Optimize

#### Train Symbol

Format: **<TRAIN>**: Initiates a Train operation.

This command will put the product into a mode of operation that will cause it to “train” the next symbol decoded. This mode of operation will remain active until either a symbol is decoded or the call is made to disable the mode and revert back to normal operation. Upon decoding a symbol, the image processing will save pertinent information regarding the target symbol to allow higher readability for the similar symbols.

The data collected by the Train operation can be saved for a power-on condition, using the **<Z>** command.

#### Un-Train Symbol

Format: **<UNTRAIN>**: Initiates an Un-Train operation.

This command will cause the product to discard any information acquired during a Train operation. The Untrained state can be saved for a power-on condition, using the **<Z>** command.

#### Train Status

Format: **<TRAIN?>**: Responds with Train Status

This command will return the current status of the TRAIN operation.

Response: **< TRAIN,0>**: Default, not trained

**<TRAIN,1>**: Train operation in process

**<TRAIN,2>**: Symbol trained

#### Train Persistence

The train state and parameters persist the same as ordinary parameters. Examples:

- A unit in the trained state has not been saved. A power cycle will remove any trained state information and the unit will come up in its configured state.
- A unit is saved in a training state. The unit will come from power up in the training state and train the first symbol read.
- A unit is saved in a trained state. The unit will come from power up in the trained state and only read the trained symbol type.
- A trained unit is issued a reset default command **<Ard>**. The unit will return to an untrained state but if power is cycled will return to its saved state.

#### Optimize Symbol

Format: **<OPT>** Initiates an Optimize operation.

This command will put the product into a mode of operation that will cause it to “optimize” the next symbol decoded. This mode of operation will remain active until either a symbol is decoded or the call is made to disable the mode and revert back to normal operation. Upon decoding a symbol, the image processing will save pertinent information regarding the target symbol to allow it to be processed quicker and more consistently.



The data collected by the Optimize operation can be saved for a power-on condition, using the **<Z>** command.

## Un-Optimize Symbol

Format: **<UNOPT>**: Initiates an Un-Optimize operation.

This command will cause the product to discard any information acquired during a Optimize operation. The Un-Optimized state can be saved for a power-on condition, using the **<Z>** command.

## Optimize Status

Format: **<OPT?>**: Responds with Optimize Status

This command will return the current status of the OPT operation.

Response: **<OPT,0>**: Default, not optimized

**<OPT,1>**: Optimize operation in-process

**<OPT,2>**: Symbol optimized

## Optimize Persistence

The Optimize state and parameters persist the same as ordinary parameters. Examples:

- A unit in the optimized state has not been saved. A power cycle will remove any optimized state information and the unit will come up in its configured state.
- A unit is saved in a optimizing state. The unit will come from power up in the optimizing state and optimize the first symbol read.
- A unit is saved in a optimized state. The unit will come from power up in the optimized state and only read the optimized symbol type.
- A optimized unit is issued a reset default command **<Ard>**. The unit will return to an un-optimized state but if power is cycled will return to its saved state.

M

### M-9-2 Y-Modem Upload Transfer Options

**<uy,path,filename>**

### M-9-3 Y-Modem Download Transfer Options

**<dy,path,filename>**

### M-9-4 Image Library Request

**<op,9>** Manages files in a selected directory.

<b>File Source</b>	<b>Explanation</b>
<b>(Nothing)</b>	All files in "root" directory
<b>/</b>	All files in "root" directory
<b>/saved</b>	All files in "saved" directory
<b>*,*</b>	All files in all directories
<b>/del</b>	Deletes all files in the root directory
<b>/saved/del</b>	Deletes all files in the saved directory
<b>del*,*</b>	Deletes files in all directories

## M-9-5 Bar Code Configuration Mode

*Definition:* **Bar Code Configuration Mode** is a way of programming the reader by using ECC 200 Data Matrix symbols.

*Serial Cmd:* **<BCCFG>**

**Bar Code Configuration Mode** can be entered in two different ways:

- 1** By forcing the reader into **Bar Code Configuration Mode** by serial command **<BCCFG>**.
- 2** By reading a Data Matrix symbol with a special code word used by ISO/IEC 16022 to signify reader programming. This can be either in a regular read cycle or during a read rate test. Reading this symbol in the calibration routine will have no effect.<sup>1</sup>

Once **Bar Code Configuration Mode** has been entered, the Data Matrix symbols can be thought of as serial data. You can configure the reader by printing labels in Omron Microscan's serial command format. Commands are processed as if the data were streamed in through the serial port. The reader will acknowledge the symbol with a green flash, and echo the serial data to the host. If the command causes the reader to produce more serial output, such as serial verification or counter requests, the data will be routed to the host port.

**Bar Code Configuration Mode** can be exited by any reset **<A>**, **<Z>** or **<J>** command.

The command to exit **Bar Code Configuration Mode** can be included as part of the Data Matrix symbol. For example, try encoding **<K200,4><K220,1><J>** into a Data Matrix symbol. This configures the reader to enable **Serial Trigger Mode**, to program a new trigger to end the read cycle, and to exit **Bar Code Configuration Mode** with **<J>**.

- **Note:** When the system is in barcode configuration mode, 2D symbols are allowed to pass through even if the reader only has a 1D license. The system outputs a Config Code Received message when the configuration symbol is decoded instead of showing the configuration symbol's actual symbol data. A > character is output to the Terminal to indicate that the system is ready for bar code configuration mode.

1. In normal reading modes, it is required to read a special Data Matrix symbol with a special codeword used by ISO/IEC 16022 to signify reader programming.

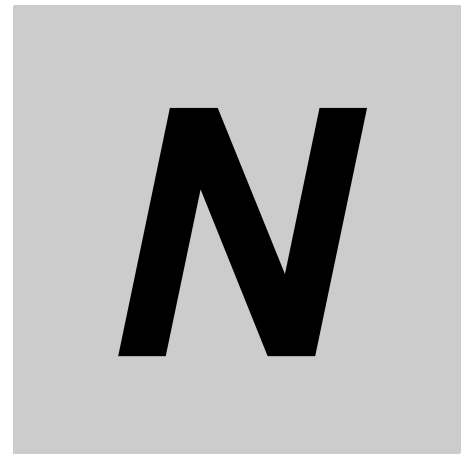

# Output Format

This section explains how to control the formatting and filtering of decoded symbol data for output.

---

<b>N-1 Output Format Serial Commands</b> .....	<b>N-2</b>
<b>N-2 Output Format Status</b> .....	<b>N-3</b>
<b>N-3 Format Assign</b> .....	<b>N-4</b>
<b>N-4 Format Extract</b> .....	<b>N-5</b>
<b>N-5 Format Insert</b> .....	<b>N-6</b>
<b>N-6 Output Filter Configuration</b> .....	<b>N-7</b>
<b>N-7 Number of Filters</b> .....	<b>N-10</b>

# N-1 Output Format Serial Commands

---

Format Extract	<K740,output index,start location,length>
Format Insert	<K741,output index,length,hex string>
Format Assign	<K742,symbol number,status>
Format Status	<K743,output format status>
Output Filter Configuration	<K744,filter number,symbology,length,wildcard,placeholder,data,unused,database index>
Output Format Count	<K745,number of filters>

## N-2 Output Format Status

---

*Definition:* This is a global enable/disable parameter. In order to use formatting you must set up the format using the insert and extract commands, and you must also assign a symbol to format using the **Format Assign** command.

*Serial Cmd:* <K743,output format status>

*Default:* Disabled

*Options:* 0 = Disabled                      1 = Enabled

N

### N-2-1 Output Format Status Disabled

When **Output Format Status** is set to **Disabled**, output formatting is globally disabled.

### N-2-2 Output Format Status Enabled

When **Output Format Status** is set to **Enabled**, output formatting is enabled. However, **Format Assign**, **Format Insert**, and **Format Extract** must be properly set up as well.

## N-3 Format Assign

### N-3-1 Symbol Number

*Definition:* **Symbol Number** refers to the number of the symbol to which output formatting will apply. For example, if you wish to enable user-defined formatting to symbol # 2 in a multisymbol read cycle, you would send the command **<K742,2,1>**.

Note that the number of symbols may exceed the format capabilities.

*Serial Cmd:* **<K742, *symbol number*, *status*>**

*Options:* 1 to 10

1 = Formatted output status for symbol # 1.

2 = Formatted output status for symbol # 2.

...

10 = Formatted output status for symbol # 10.

### N-3-2 Status

*Definition:* **Status** refers to the user-defined formatting of a selected symbol position in the read cycle result. Note that there is also a global formatting “enable” command that must be set for the formatting to be applied.

*Serial Cmd:* **<K742, *symbol number*, *status*>**

*Default:* **Disabled**

*Options:* **0 = Disabled**      1 = Enabled (Assign parameters to specified symbol.)

## N-4 Format Extract

### N-4-1 Output Index

*Definition:* **Output Index** refers to the database entry you wish to modify with this command. A formatted output is built by *extracting data from a symbol's original data output* and/or inserting user-defined characters.

It may be helpful to think of individual indexes as positions in the final formatted output you wish to build. Starting with index # 1, enter either an extract or insert command to begin building your desired output string. Then, with the next index number, enter either an extract or insert command to continue building the output string. Continue this process until you are finished building the string.

*Serial Cmd:* <**K740,output index,start location,length**>

*Options:* 1 to 100

### N-4-2 Start Location

*Definition:* Defines the location within the symbol data where the character extraction will begin. The first character extracted will also be the first character in the sequence displayed in user-defined output.

*Serial Cmd:* <**K740,output index,start location,length**>

*Default:* **0 (disabled)**

*Options:* 0 to *n* (maximum number of characters in the symbol data).

### N-4-3 Length

*Definition:* Defines the length (in consecutive characters) that will be extracted and placed in user-defined output.

*Serial Cmd:* <**K740,output index,start location,length**>

*Default:* **0** (disabled; end of format cell array)

*Options:* 0 to *n* (maximum number of characters in the symbol data).

## N-5 Format Insert

### N-5-1 Output Index

**Definition:** **Output Index** refers to the database entry you wish to modify with this command. A formatted output is built by extracting data from a symbol's original data output and/or *inserting user-defined characters*.

It may be helpful to think of individual indexes as positions in the final formatted output you wish to build. Starting with index # 1, enter either an extract or insert command to begin building your desired output string. Then, with the next index number, enter either an extract or insert command to continue building the output string. Continue this process until you are finished building the string.

**Serial Cmd:** <K741,**output index**,length,hex string>

**Options:** 1 to 100

### N-5-2 Length

**Definition:** Specifies the length of the user-defined character string that will be inserted. This function is limited to 4 characters per output index, so multiple indexes must be entered in order to insert longer character sequences.

For example, if you wish to insert a 10 character sequence in user-defined output, you would need three commands with consecutive index numbers, where the first two character sequence lengths were 4 and the third was 2.

**Serial Cmd:** <K741,**output index**,length,hex string>

**Default:** 0 (disabled; end of format cell array)

**Options:** 0 to 4

### N-5-3 Hex String

**Definition:** Specifies a character string that represents ASCII characters to be inserted in the database entry. Two hex characters are required for every ASCII character to be inserted in the user-defined output string. These two characters comprise the hex (base 16) value of the ASCII character.

For example, if you wanted to enter the three-character sequence "Hi!" you would enter 3 for the length of the string, and a hex sequence of **486921** for the ASCII sequence to be inserted. (48 = H; 69 = i; 21 = !)

**Important:** Each pair of hex characters represents one ASCII character. Hex character pairs range from 00 to FF. Since you are limited to 4 ASCII characters per insertion per database entry, you are likewise limited to 8 hex characters per insertion per database entry.

**Serial Cmd:** <K741,**output index**,length,hex string>

**Default:** NUL (00 in hex)

**Options:** 00 to FF (As many as 4 bytes, or hex values.)



## N-6 Output Filter Configuration

*Definition:* Output filtering is a method of providing a set of good read qualifiers and also providing ordered output. There is a filter for up to the first 10 positions in a multisymbol output. The first filter corresponds to the first symbol output at the end of the read cycle. Each filter has settings for the following four parameters: **Symbology**, **Symbol Length**, **Data**, and **Configuration Database Number**.

*Serial Cmd:* <K744,filter number,symbology,length,wildcard,placeholder,data,unused,database index>

N

### N-6-1 Rules for Output Filter Configuration

#### Output Filter Configuration Rule # 1

Each symbol that is decoded must match one of the filters before it can be saved to a read cycle record. There is an exception to this rule, however, when the number of symbols required for a read cycle exceeds the number of active filters. In such a case, unfiltered symbols can be placed into unfiltered output positions.

For example, if the number of symbols required is 6 but there are only 4 active filters, the last 2 positions can be filled by any (unfiltered) qualified symbol.

#### Output Filter Configuration Rule # 2

The same filter setup can be used multiple times.

For example, filters 1, 2, and 3 can be set up to filter Data Matrix symbols, and the output will occur in the order the symbols are decoded.

#### Output Filter Configuration Rule # 3

All qualified symbols will be sorted and output in the matching filter position. If a symbol matches filter 3, it will be output as the third symbol. If a filter does not have a matching qualified symbol, a No-Read message will be output in place of the symbol (assuming the No-Read message is enabled).

For example, if there is not a symbol that meets filter 3's requirements, then a No-Read message will be output in the third output position.

### N-6-2 Filter Number

*Definition:* This is the filter index number that represents the position of the symbol in the data output at the end of the read cycle. This index number should be entered along with the following filter settings for the predetermined symbol position.

*Serial Cmd:* <K744,filter number,symbology,length,wildcard,placeholder,data,unused,database index>

*Options:* 1 to 10

### N-6-3 Placeholder

**Definition:** The placeholder character requires a character to be present, but does not compare the data value.

**Serial Cmd:** <**K744**, filter number, symbology, length, wildcard, **placeholder**, data, unused, database index>

**Default:** " ? " = **3F** (hex)

**Options:** Any ASCII input in the form of a pair of hex characters.

Example:

3F = ?

00 = disabled

### N-6-4 Data

**Definition:** This is the data string to be used when comparing symbol data for output filtering and ordering. This data string may also contain wildcard and placeholder characters to facilitate matching. Remember that in order to filter or order symbol data, it must meet all the requirements of the selected filter index.

**Examples:**

- Filter data = "123\*". This will match data strings of "123", "123456", and "123ABC", but not "12".
- Filter data = "123\*AB?C". This will be interpreted as "123\*".
- Filter data = "123?". This will match "1234" and "123A", but not "123", "12345", or "1234C".
- Filter data = "123?A". This will match "1234A" and "123BA", but not "123", "1234C", or "1234ABCD".
- Filter data = "123?A?". This will match "1234AB" and "123BAT", but not "1234A" or "123BATS".
- Filter data = "12??\*". This will match "1234", "123456", and "123ABC", but not "12" or "123".
- Filter data = "123?A\*". This will match "1234A", "123BA", and "123BATS", but not "1234" or "1234C".

**Serial Cmd:** <**K744**, filter number, symbology, length, wildcard, **placeholder**, **data**, unused, database index>

**Default:** **00** (NUL)

**Options:** Any ASCII input in the form of a pair of hex characters.

Maximum length: 63 bytes defined.

Examples:

41422A = AB\*

Data [0] = NUL represents string matching disabled.

### N-6-5 Database Index

**Definition:** The index of the database entry that decodes a given symbol must equal this setting for filtering to occur. A setting of **0** allows any database index for this filter entry.

**Serial Cmd:** <**K744**, filter number, symbology, length, wildcard, **placeholder**, data, unused, **database index**>

**Default:** **0** (any index)

**Options:** 0 to 10

## N-7 Number of Filters

---

*Definition:* **Number of Filters** refers to the number of active output filters. **0** disables all output filters. Any non-zero numeral will enable filtering to be performed using the filter indexes covered by this value.

For example, if the number of filters is **1**, then only filter index # 1 will be applied. If the number of filters is **2**, then only filter index # 1 and filter index # 2 will be applied, etc.

*Serial Cmd:* <**K745,number of filters**>

*Default:* **0**

*Options:* 0 to 10

N



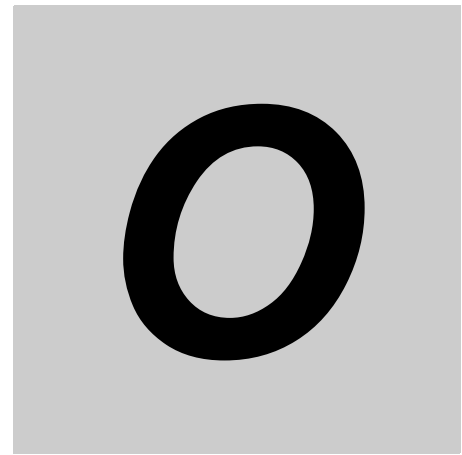

# Communications Protocol

This section contains a communications protocol command table for MicroHAWK readers.

---

<b>O-1</b>	<b>Communications Protocol Command Table.....</b>	<b>O-2</b>
------------	---	------------

# O-1 Communications Protocol Command Table

---

Protocol Command (Mnemonic displayed on menu)	Control Characters (Entered in menu or serial command)	Hex Value	Effect of Command
RES	^D	04	Reset
REQ	^E	05	Request
EOT	^D	04	Reset
STX	^B	02	Start of Text
ETX	^C	03	End of Text
ACK	^F	06	Acknowledge
NAK	^U	15	Negative Acknowledge
XON	^Q	11	Begin Transmission
XOFF	^S	13	Stop Transmission



# ASCII Table



This section contains an ASCII table.

---

P-1 ASCII Table ..... P-2

# P-1 ASCII Table

Dec	Hex	Mne	Ctrl	Dec	Hex	Ch	Dec	Hex	Ch	Dec	Hex	Ch
00	00	NUL	^@	32	20	SP	64	40	@	96	60	`
01	01	SOH	^A	33	21	!	65	41	A	97	61	a
02	02	STX	^B	34	22	"	66	42	B	98	62	b
03	03	ETX	^C	35	23	#	67	43	C	99	63	c
04	04	EOT	^D	36	24	\$	68	44	D	100	64	d
05	05	ENQ	^E	37	25	%	69	45	E	101	65	e
06	06	ACK	^F	38	26	&	70	46	F	102	66	f
07	07	BEL	^G	39	27	'	71	47	G	103	67	g
08	08	BS	^H	40	28	(	72	48	H	104	68	h
09	09	HT	^I	41	29	)	73	49	I	105	69	i
10	0A	LF	^J	42	2A	*	74	4A	J	106	6A	j
11	0B	VT	^K	43	2B	+	75	4B	K	107	6B	k
12	0C	FF	^L	44	2C	,	76	4C	L	108	6C	l
13	0D	CR	^M	45	2D	-	77	4D	M	109	6D	m
14	0E	SO	^N	46	2E	.	78	4E	N	110	6E	n
15	0F	SI	^O	47	2F	/	79	4F	O	111	6F	o
16	10	DLE	^P	48	30	0	80	50	P	112	70	p
17	11	DC1	^Q	49	31	1	81	51	Q	113	71	q
18	12	DC2	^R	50	32	2	82	52	R	114	72	r
19	13	DC3	^S	51	33	3	83	53	S	115	73	s
20	14	DC4	^T	52	34	4	84	54	T	116	74	t
21	15	NAK	^U	53	35	5	85	55	U	117	75	u
22	16	SYN	^V	54	36	6	86	56	V	118	76	v
23	17	ETB	^W	55	37	7	87	57	W	119	77	w
24	18	CAN	^X	56	38	8	88	58	X	120	78	x
25	19	EM	^Y	57	39	9	89	59	Y	121	79	y
26	1A	SUB	^Z	58	3A	:	90	5A	Z	122	7A	z
27	1B	ESC	^[	59	3B	;	91	5B	[	123	7B	{
28	1C	FS	^\	60	3C	<	92	5C	\	124	7C	
29	1D	GS	^]	61	3D	=	93	5D	]	125	7D	}
30	1E	RS	^^	62	3E	>	94	5E	^	126	7E	~
31	1F	US	^_	63	3F	?	95	5F	_	127	7F	D





# Glossary of Terms



This section contains a glossary of terms relevant to MicroHAWK readers.

---

Q-1	Glossary of Terms .....	Q-2
-----	-------------------------	-----

# Q-1 Glossary of Terms

---

**Aberration** — The failure of an optical lens to produce an exact point-to-point correspondence between the object and its resulting image. Various types are chromatic, spherical, coma, astigmatism and distortion.

**Absorption** — The loss of light of certain wavelengths as it passes through a material and is converted to heat or other forms of energy. (–)

**Active Illumination** — Lighting an area with a light source coordinated with the acquisition of an image. Strobed flash tubes and pulsed lasers are examples.

**Ambient Light** — Light which is present in the environment of the imaging front end of a vision system and generated from outside sources. This light, unless used for actual illumination, will be treated as background **Noise** by the vision system.

**Analog** — A smooth, continuous voltage or current signal or function whose magnitude (value) is the information.

**Analog-to-Digital Converter (A/D Converter or ADC)** — A device that converts an analog voltage or current signal to a discrete series of digitally encoded numbers (signal) for computer processing.

**Application-Specific Integrated Circuit (ASIC)** — An integrated circuit that is customized for a particular kind of use, rather than general use. All vision system elements including firmware can be integrated into one ASIC.

**Architecture** — The hardware organization of a vision system designed for high speed image analysis.

**Aspect Ratio** — The ratio between the height and width of a sensor or display. Found by dividing the vertical number of pixels (height) by the horizontal number of pixels (width) leaving it in fractional format.

**Automatic Gain Control (AGC)** — Adjustment to signal strength that seeks to maintain a constant level regardless of the distance between a reader and symbol.

**Auxiliary Port** — RS-232 connection to an auxiliary terminal or device for remote viewing.

**Blooming** — A situation in which too many photons are being produced to be received by a pixel. The pixel overflows and causes the photons to go to adjacent pixels. Blooming is similar to overexposure in film photography, except that in digital imaging, the result is a number of vertical and/or horizontal streaks appearing from the light source in the picture.

**Baud Rate** — The number of discrete signal events per second; bits per second.

**Capture** — The act of acquiring and storing video images in an imager or host computer. Also, the image captured.

**Charge-Coupled Device (CCD)** — A semiconductor device with an array of light-sensitive elements that converts light images into electrical signals.

**Check Character** — A Modulus 43 or Modulus 10 character that is added to encoded symbol data for additional data integrity.

**Complementary Metal Oxide Semiconductor (CMOS)** — Like CCDs, CMOS imagers include an array of photo-sensitive diodes, one diode within each pixel. Unlike CCDs, however, each pixel in a CMOS imager has its own individual amplifier integrated inside.

**Connector** — A plug or socket on a device or cable providing in/out connectivity for various circuits and pins.

**Concentrator** — Intermediary device that relays data from imagers to a host and commands from the host to the imagers or other devices.

**Counter** — Memory space allocated to keep track of imager events.

**Daisy Chain** — Linkage of primary and secondary imagers allowing data to be relayed up to the host via auxiliary port connections.

**Decode** — A **Good Read**. The successful interpretation and output of the information encoded in a symbol.

**Default** — Restores **ROM** or flash settings, initializes serial commands and resets all counters.

**Delimited** — A delimited command or field is bracketed by predefined characters.

**Decode Rate** — The number of good reads per second achieved by an imager.

**Dark Field Illumination** — Lighting of objects, surfaces, or particles at very shallow or low angles, so that light does not directly enter a reader's optical hardware.

**Depth-of-Field** — The in-focus range of an imaging system. Measured from the distance behind an object to the distance in front of the object with all objects appearing in focus.

**Diffused Lighting** — Scattered soft lighting from a wide variety of angles used to eliminate shadows and specular glints from profiled, highly reflective surfaces.

**Digital-to-Analog Converter (DAC)** — A **VLSI** circuit used to convert digitally processed images to analog for display on a monitor.

**Digital Imaging** — Conversion of an image into pixels by means of an **Analog-to-Digital Converter** where the level of each pixel can be stored digitally.

**Digital Signal Processor (DSP)** — A **VLSI** chip designed for ultra-high-speed arithmetic processing. Often imbedded in a vision engine.

**Discrete I/O** — Inputs and outputs characterized by discrete signal transitions from one voltage level to another so that digital switching can occur.

**Direct Memory Access (DMA)** — A capability provided by some computer bus architectures that allows data to be sent directly to memory from an attached device.

**Dynamic Range** — The difference between the minimum and maximum thresholds of discernible images; the amount of usable signal.

**Edge Enhancement** — Image processing method to strengthen high-spatial frequencies in the image.

**Embedded Memory** — Onboard memory device such as **EPROM** or flash.

**End of Read Cycle** — The time or condition at which the imager stops expecting symbol information to decode.

**Erasable Programmable Read-Only Memory (EPROM)** — A memory chip that retains data when its power supply is turned off; "non-volatile memory".

**External Edge** — Allows a read cycle to be initiated by a trigger signal from an object detector when it detects the appearance of an object (rising edge). The read cycle ends with a good read, a timeout, or a new trigger.

**External Level** — Allows a read cycle to be initiated by a trigger signal from an object detector. The read cycle ends when the object moves out of the detector's range.

**Falling Edge** — A change of state (to inactive) associated with a level trigger.

**Field-Programmable Gate Array (FPGA)** — A semiconductor device containing programmable interconnects and logic components.

**Fill Factor** — Percentage of pixel area used for light collection.

**Firmware** — Software hard-coded in non-volatile memory (**ROM**), and closely tied to specific pieces of hardware.

**Fixed Symbol Length** — Increases data integrity by ensuring that only one symbol length will be accepted.

**Focal Distance** — In camera-based vision, the distance from the front of the camera to the object being viewed. (In optics, the distance from the lens to the focal plane.)

**Focal Plane** — Usually found at the image sensor, it is a plane perpendicular to the lens axis at the point of focus (–).

**Focus** — Any given point in an image at which light converges; the focal point.

**Frame** — The total area captured in an image sensor while the video signal is not blanked.

**Frame Grabber** — A device that interfaces with a camera and, on command, samples the video, converts the sample to a digital value and stores that in a computer's memory.

**Front End System** — The object, illumination, optics and imager blocks of a vision system. Includes all components useful to acquire a good image for subsequent processing.

**Full Duplex** — A communications system in which signals can travel simultaneously between devices.

**Gain** — The amount of energy applied to pixel gray scale values prior to output, expressed in dB; optimal signal strength.

**Good Read** — A decode. The successful scanning and decoding of the information encoded in a bar code symbol.

**Gradient** — The rate of change of pixel intensity (first derivative).

**Gray Scale** — Variations of values from white, through shades of gray, to black in a digitized image with black assigned the value of zero and white the value of one.

**Half Duplex** — A communications system in which signals can travel between devices in both directions, but not simultaneously.

**Histogram** — A graphical representation of the frequency of occurrence of each intensity or range of intensities (gray levels) of pixels in an image. The height represents the number of observations occurring in each interval.

**Host** — A computer, **PLC**, or other device that is used to execute commands and process data and discrete signals.

**Image** — Projection of an object or scene onto a plane (i.e. screen or image sensor).

**Image Processing (IP)** — Transformation of an input image into an output image with desired properties.

**Image Resolution** — The number of rows and columns of pixels in an image. A higher resolution means that more pixels are available per element of the symbol being read. Examples: 640 x 480 (VGA); 854 x 480 (WVGA); 1280 x 1024 (SXGA); 2048 x 1536 (QXGA).

**Image Sensor** — A device that converts a visual image to an electrical signal; a **CCD** or **CMOS** array.

**Initialize** — Implement serial configuration commands into the imager's active memory.

**Input** — A channel or communications line. Decoded data or a discrete signal that is received by a device.

**Integration** — Exposure of pixels on a **CMOS** sensor.

**Ladder Orientation** — A linear symbol orientation in which the bars are parallel to the symbol's direction of travel.

**Light-Emitting Diode (LED)** — A semiconductor device that emits light when conducting current.

**Lens** — A transparent piece of material with curved surfaces which either converge or diverge light rays.

**Machine Vision** — The automatic acquisition and analysis of images to obtain desired data for controlling a specific activity.

**Multidrop** — A communications protocol for networking two or more imagers or other devices with a concentrator (or controller) and characterized by the use of individual device addresses and the RS-485 standard.

**Noise** — The same as static in a phone line or "snow" in a television picture, noise is any unwanted electrical signal that interferes with the image being read and transferred by the imager.

**Normally Closed** — A discrete output state that is only active when open.

**Normally Open** — A discrete output state that is only active when closed.

**Object Plane** — An imaginary plane in the field of view, focused by an imager's optical system at the corresponding image plane on the sensor.

**Output** — A channel or communications line. Data or discrete signals that are transmitted or displayed by a device.

**Parity** — An error detection routine in which one data bit in each character is set to **1** or **0** so that the total number of **1** bits in the data field is even or odd.

**Picket Fence Orientation** — A linear symbol orientation in which the bars are perpendicular to the symbol's direction of travel.

**Pitch** — Rotation of a linear or 2D symbol around an axis parallel to the symbol length on the Substrate.

**Pixel** — An individual element in a digitized image array; "picture element".

**Port** — Logical circuit for data entry and exit. (One or more ports may be included within a single connector.)

**Processing Time** — The time used by a vision system to receive, analyze and interpret image information. Often expressed in "parts per minute".

**Programmable Logic Controller (PLC)** — An electronic device used in industrial automation environments such as factory assembly lines and automotive manufacturing facilities.

**Progressive Scan** — A non-interlaced scan that doubles the number of visible picture lines per field by displaying all picture lines at once.

**Protocol** — The rules for communication between devices, providing a means to control the orderly flow of information between linked devices.

**Random Access Memory (RAM)** — A data storage system used in computers, composed of integrated circuits that allow access to stored data in any sequence without movement of physical parts.

**Read Cycle** — A programmed period of time or condition during which a reader will accept symbol input.

**Read-Only Memory (ROM)** — A data storage medium used in computers and other electronics, primarily used to distribute **Firmware**.

**Real-Time Processing** — In machine vision, the ability of a system to perform a complete analysis and take action on one part before the next one arrives for inspection.

**Region** — Area of an image. Also called a region of interest for image processing operations.

**Saturation** — The degree to which a color is free of white. One of the three properties of color perception, along with hue and value.

**Scattering** — Redirection of light reflecting off a surface or through an object.

**Skew** — Rotation of a linear or 2D symbol around an axis parallel to the symbol height on the substrate.

**Substrate** — The surface upon which a linear or 2D symbol is printed, stamped, or etched.

**Symbol Transitions** — The transition of bars and spaces on a symbol, used to detect the presence of a symbol on an object.

**Symbology** — A symbol type, such as Code 39 or Code 128, with special rules to define the widths and positions of bars and spaces to represent specific numeric or alphanumeric information.

**Tilt** — Rotation of a linear or 2D symbol around an axis perpendicular to the substrate.

**Trigger** — A signal, transition, or character string that initiates a read cycle.

**Very Large-Scale Integration (VLSI)** — The creation of integrated circuits by combining thousands of transistor-based circuits on a single chip.

**Watchdog Timer** — A security device that detects system crashes and attempts to reset the imager.





# Q & A



This section answers some common questions about MicroHAWK functionality.

---

R-1 Q & A ..... R-2

# R-1 Q & A

Question	Answer
Is the settings possible without any PC tool and PLC?	<p>It is possible to do by reading a DataMatrix for the setting.</p> <p>The following describes how to generate DataMatrix for the setting.</p> <ol style="list-style-type: none"> <li>1. Connect V430.</li> <li>2. Receive the setting data of V430.</li> <li>3. Select the <b>Utilities - Differences</b> Tab.</li> <li>4. Click the <b>Differences from Default</b> Button.</li> <li>5. Click the <b>Generate Bar Code</b> Button.</li> <li>6. As The <b>Bar code configuration</b> dialog appears, place a check to the <b>Add Start configuration code</b> and <b>Add end configuration code</b>; <b>Save Settings</b>.</li> <li>7. Click the <b>Print</b> Button to print the DataMatrix for the settings.</li> </ol> <p>The following describes how to read the DataMatrix for the settings.</p> <ol style="list-style-type: none"> <li>1. To reflect the settings, turn on V430 in the factory shipment.state. → (In the factory shipment) the state is set to <b>Continuous Read</b>.</li> <li>2. Read the <b>Add start configuration</b> code first. → The LEDs on the device flash in order. (<b>Bar Code Configuration Mode</b>)</li> <li>3. Read the DataMatrix generated for setting commands in order.</li> <li>4. Read <b>Add end configuration</b> code in the last. → The <b>Bar code configuration mode</b> ends and the settings are saved.</li> </ol>
What is PPE?	<p>PPE stands for <b>Pixel Per Element</b>.</p> <p>For 2D code, it is one cell size on a captured image. For 1D code (barcode), it is the minimum bar width on a captured image. e.g. When [PPE=4.0] is displayed on WebLink at DataMatrix read, the DataMatrix cell size is four pixels on the captured image.</p>
When magnifying an image on WebLink, it blurs.	<p>On WebLink, compressed images are displayed. Since such images have lower resolution than measured images, therefore they might be blur when magnifying them. When magnifying a measured image with an actual resolution, use saved images. For the image saving method, refer to Q&amp;A: <i>How to save read images</i>.</p>
How to react when being unable to WebLink.	<ul style="list-style-type: none"> <li>• <b>For Internet Explorer, check the following settings.</b> Uncheck the upper right <b>Tool icon - Compatibility View settings - Display Intranet sites in Compatibility View</b>. Or use Google Chrome.</li> <li>• <b>Turn off the VPN function.</b> Turn off the VPN function. When the VPN function is turned on, local LAN connections other than the VPN are disabled all.</li> <li>• <b>Check the IP address using DDU.</b> DDU (Discovery Device Utility) is a tool to search a V430 whose IP address is lost. When the search was succeeded, its IP address also can be changed. Download the DDU from Omron Microscan Web site.</li> <li>• <b>Initialize V430 if the above measures does not help.</b> Related Q&amp;A: <i>How to initialize the settings?</i></li> </ul>
About WebLink	<p>The merits of WebLink are that does not require the installation and is easily operated to set with a Web browser. Use WebLink basically. Most of the functions are settable except for some functions. The following shows a list of comparison.</p> <p>WebLink Merits:</p> <ul style="list-style-type: none"> <li>• No installation software (Web browser)</li> <li>• Japanese supported</li> <li>• Visually easy to understand UI</li> </ul>
Can the position information of a code be output?	<p>Enable <b>Advanced - I/O - Output Object Info - Output Coordinates</b>. Following the captured string, every four vertexes of the code are output.</p> <ul style="list-style-type: none"> <li>• Output example: When a code of 123456 was captured 123456,(0032,0040)(0287,0056)(0287,0279)(0048,0271)</li> </ul>
Can serial commands calibrate brightness or focus?	<p>It is possible to adjust with a serial command &lt;@CAL&gt; executing the calibration. Which parameter should be adjusted at Calibration, it is selectable with the following parameter on WebLink.</p> <p><b>Advanced - I/O tab - Calibration Options</b></p> <p>When executing the &lt;@CAL&gt; command, V430 outputs numeric values indicating trial results in some rows and then <b>Calibration PASSED</b>. When failed, <b>Calibration FAILED</b> is output. Example of a response when &lt;@CAL&gt; was succeeded.: Prog  Exposure Gain Brightness 2   5764 33 24 100   6011 33 37 Calibration PASSED.</p>



<p>How is a trigger inputted in serial communications?</p>	<p>The following describes a serial command to input a trigger in default.</p> <ul style="list-style-type: none"> <li>Serial Trigger command</li> </ul> <p>ASCII character notation &lt; &gt;          Hex notation 3C 20 3E</p> <p>Although space is a default in the center (Hex notation: 20), it can be changed to any ASCII character from the menu below.</p> <p>WebLink - Gear icon - <b>Advanced - Read Cycle - Serial Trigger - Serial Trigger Character (Delimited)</b></p> <p>Additionally, from the menu below, any ASCII character can be set up to two characters for Start Trigger Character/Stop Trigger Character that do not need &lt; &gt;.</p> <p>WebLink - Gear icon - <b>Advanced - Read Cycle - Serial Trigger - Start Trigger Character (Non-Delimited)/Stop Trigger Character (Non-Delimited)</b></p>										
<p>What kind of effect is in Teaching?</p>	<p>When Teaching (Hat icon on WebLink) was executed, judgment of code type and the detection algorithm optimization are performed.</p> <p>When reading codes with the same conditions, the reading will be more stable just to execute Teaching.</p> <p>However, Teaching is not a function that always needs be executed.</p>										
<p>How to access a RAM drive from a PC?</p>	<p>A PC can access a RAM drive using the FTP client tool.</p> <p>The initial values of V430 are as follows.</p> <table border="1" data-bbox="456 667 911 801"> <thead> <tr> <th>Settings</th> <th>Value</th> </tr> </thead> <tbody> <tr> <td>IP address</td> <td>192.168.188.2</td> </tr> <tr> <td>Path</td> <td>imagesd0/images/</td> </tr> <tr> <td>Account</td> <td>target</td> </tr> <tr> <td>Password</td> <td>password</td> </tr> </tbody> </table> <p>Example: When using Internet Explorer to access.</p> <ol style="list-style-type: none"> <li>1. If the IP address is the default, enter <i>ftp://192.168.188.2/imagesd 0/images/</i> in the address bar to connect.</li> <li>2. Enter your account and password.</li> <li>3. Download the file saved in the RAM drive to your PC.</li> </ol>	Settings	Value	IP address	192.168.188.2	Path	imagesd0/images/	Account	target	Password	password
Settings	Value										
IP address	192.168.188.2										
Path	imagesd0/images/										
Account	target										
Password	password										



<p>Parallel communications timing chart</p>	<p>The parallel output signals, OUTPUT1/OUTPUT2/OUTPUT3, can change those roles by the output condition settings.                  The default is that those are turned on when all are No-Read.                  WebLink - Gear icon - <b>Advanced - I/O - OUTPUT1 parameters - Output On</b>                  Additionally, a timing to turn off can also be adjusted using the following setting.                  WebLink - Gear icon - <b>Advanced - I/O - OUTPUT1parameters - Output Mode</b></p> <p>When you want to detect a timing that the output is changed, set the output condition for one of OUTPUT1/OUTPUT2/OUTPUT3 to <b>In Read Cycle</b>.                  According to the setting, it turns on in a period from detecting a trigger, reading, and end of output.</p> <p>For example, the following describes a timing chart in a case of a setting below.</p> <ul style="list-style-type: none"> <li>• Output On                      OUTPUT1 In Read Cycle                      OUTPUT2 Match or Good Read                      OUTPUT3 Mismatch or No-Read</li> <li>• Timing chart</li> </ul> <p>&lt;Output Mode: Pulse case&gt;</p> <p>&lt;Output Mode: Latch Mode 2 (Status held) case&gt;</p> <p>&lt;Output Mode: Latch Mode 3 (OFF at In Read Cycle started) case&gt;</p>
	<p>How to estimate an exposure time when reading a moving symbol?</p> <p>A moving amount of a symbol during exposure should be 1/10 or less of the cell size (for barcode, narrow bar width).                  When a cell size is C [mm] and a line speed is L [mm/s], use the following formula to get the exposure time S.  <math>S \leq 0.1 \times C / L</math>                  For example, When a cell size is 0.3 [mm] and a line speed is 300 [mm/s], the exposure time should be 100 [μs] or less.  <math>0.1 \times 0.3 \text{ [mm]} / 300 \text{ [mm/s]} = 100 \text{ [μs]}</math></p>



<p><b>Read Rate of Counts</b> on the right panel is not available.</p>	<p><b>Read Rate of Counts</b> on the right panel is sometimes not available depending on the setting of Read Cycle.</p> <table border="1" data-bbox="454 271 1062 439"> <thead> <tr> <th>Read Cycle</th> <th>Read Rate</th> </tr> </thead> <tbody> <tr> <td>Presentation</td> <td>Unavailable</td> </tr> <tr> <td>Continuous Read</td> <td>Unavailable</td> </tr> <tr> <td>Triggered</td> <td>Available</td> </tr> <tr> <td>Start/Stop</td> <td>Available</td> </tr> <tr> <td>Custom</td> <td>Refer to below</td> </tr> </tbody> </table> <p>When Read Cycle is <b>Custom</b>, it sometimes is unavailable depending on the setting of Trigger Mode.</p> <table border="1" data-bbox="454 521 1062 741"> <thead> <tr> <th>Trigger Mode</th> <th>Read Rate</th> </tr> </thead> <tbody> <tr> <td>Continuous Read</td> <td>Unavailable</td> </tr> <tr> <td>Continuous Read 1 Output</td> <td>Unavailable</td> </tr> <tr> <td>External Level</td> <td>Available</td> </tr> <tr> <td>External Edge</td> <td>Available</td> </tr> <tr> <td>Serial Data</td> <td>Available</td> </tr> <tr> <td>Serial Data and Edge</td> <td>Available</td> </tr> <tr> <td>Continuous Read Auto</td> <td>Unavailable</td> </tr> </tbody> </table>	Read Cycle	Read Rate	Presentation	Unavailable	Continuous Read	Unavailable	Triggered	Available	Start/Stop	Available	Custom	Refer to below	Trigger Mode	Read Rate	Continuous Read	Unavailable	Continuous Read 1 Output	Unavailable	External Level	Available	External Edge	Available	Serial Data	Available	Serial Data and Edge	Available	Continuous Read Auto	Unavailable
Read Cycle	Read Rate																												
Presentation	Unavailable																												
Continuous Read	Unavailable																												
Triggered	Available																												
Start/Stop	Available																												
Custom	Refer to below																												
Trigger Mode	Read Rate																												
Continuous Read	Unavailable																												
Continuous Read 1 Output	Unavailable																												
External Level	Available																												
External Edge	Available																												
Serial Data	Available																												
Serial Data and Edge	Available																												
Continuous Read Auto	Unavailable																												
<p>Only one image can save.</p>	<p>When <b>Save Image</b> Until is set to <b>New Read Cycle</b>, only last one image is saved. When saving multiple images, set WebLink - Gear icon - <b>Advanced - Image Storage - Save Image Until to System Reset</b>. Additionally, when <b>Image Storage Location</b> was set to <b>FTP</b>, images might not be saved due to the shorter read interval if <b>Transfer Optimization</b> is set to <b>Speed (Lossy)</b>. When you want to prioritize the image storage over the read, set WebLink - Gear icon - <b>Advanced - Image Storage - Transfer Optimization to Accuracy (Lossless)</b>.</p>																												
<p>How to acquire or change the settings from external?</p>	<p>With the serial communications, it is possible to do so using a serial command so called K command. For each K command, refer to Chapter 3 or later. Example: Set the exposure time to 1,000 [μs]. Command: &lt;K541,1000&gt; Response: None</p> <p>As adding "?" to a K command, the setting value will be returned. Example: Acquire the current exposure time and gain. Command: &lt;K541?&gt; Response: &lt;K541,1000,30&gt; Presently, the exposure time is set to 1,000 [μs] and the gain is set to 30 [%].</p>																												
<p>How can I read multiple codes in the field of view?</p>	<p>When the string of codes are different from each other, multiple codes in the field of view can be read.</p> <ul style="list-style-type: none"> <li>• Settings To enable multiple reads, change the value of default <i>Look for 1 Symbols</i> in <b>Read Cycle</b> at the left on the setup screen. Or, change the settings below. WebLink - Gear icon - <b>Advanced - Read Cycle - Multisymbol - Number of Symbols</b></li> <li>• Output order The output order is practically random because of the order of completed read. Using the <b>Configuration Database</b> or <b>Order Output Filter</b> functions with serial commands, up to 10 output order can be controlled (when symbols satisfy the output conditions).</li> <li>• Cautions Multiple reads are not available in codes with the same string.</li> </ul>																												
<p>Is it possible to specify the output range for output string?</p>	<p>Turn on <b>Output Format</b> at the left on the WebLink setup screen. With clicking format strings, <b>Output Formatting Editor</b> screen opens. With enabling <b>Parse Symbol</b>, the output range can be specified.</p>																												

What kinds of lighting patterns are adopted?	LED	Purpose	WebLink Setting menu	Simultaneous lighting															
	Outside LED	Imaging LED Mainly use when illuminating a wide range. 5M type is white. 0.3M and 1.2M types are red.	<b>Advanced - Camera Setup - Camera Settings</b>	These three cannot be turned on simultaneously. Only one of the lighting patterns can be set.															
	Inside red LED	Imaging LED Use this when red color lighting is needed.																	
	Inside white LED	Imaging LED Use this when illuminating a narrow range. The purpose is changeable with the setting.																	
	Green LED	Illuminate at a good read (default). Additional green lighting at imaging. Target pattern lighting.	<b>Advanced - I/O - Output Indicator</b>	Possible to turn it on with other lighting LED simultaneously.															
	Blue LED	This turns on when leading the image center position to the cross part of the blue lighting.																	
Is the lighting brightness adjustable?	The lighting brightness is adjustable using the menu on WebLink. Gear icon - <b>Advanced - Camera Settings - Illumination Brightness</b>																		
How to output the same code only once in Constant Read state?	To output the same code only once in Constant Read state with V430, set the following. • Gear icon - <b>Advanced - Read Cycle - Trigger - Mode: Continuous Read 1 Output</b> • Gear icon - <b>Advanced - Read Cycle - End of Read Cycle - Mode: New Trigger</b> With the above setting, V430 in Constant Read state reads the same code only once and only output it when a code different from the previous code is read. When you want to set V430 so that it can read the same code again after some time passed, set <b>End of Read Cycle Mode to Timeout and adjust Read Cycle Timeout.</b>																		
How to initialize the settings?	<p>There are three initialization methods.</p> <ul style="list-style-type: none"> <li>• <b>Initialization by operating the menu on WebLink</b> <ol style="list-style-type: none"> <li>1. Click the Gear icon at the right of WebLink.</li> <li>2. Click the Restore Default Settings Button.</li> </ol>                     * This performs an initialization processing as same as a serial command &lt;Zrd&gt;.                 </li> <li>• <b>Boot while pressing the Setup Button.</b>  <i>Customer Default Parameters</i> are loaded.                     <ol style="list-style-type: none"> <li>1. Hold down the Setup Button on the main body and turn on the power.</li> <li>2. Keep the state for approx. 30 seconds.</li> </ol>                     * This performs an initialization processing as same as a serial command &lt;Zrd&gt;.                 </li> <li>• <b>Initialization by DEFAULT signal of parallel.</b>                      It resets the hardware. The following I/O signals are used.                     <table border="1" style="width: 100%; border-collapse: collapse;"> <thead> <tr> <th>Line color</th> <th>PIN No.</th> <th>Signal name</th> </tr> </thead> <tbody> <tr> <td>Brown</td> <td>2</td> <td>24 VDC (Power)</td> </tr> <tr> <td>Green</td> <td>3</td> <td>Default</td> </tr> <tr> <td>Blue</td> <td>7</td> <td>0 VDC (Ground)</td> </tr> <tr> <td>Red</td> <td>8</td> <td>COM_IN</td> </tr> </tbody> </table> </li> </ul> <p>Before turning on, connect PIN 2 and 8. Perform the following procedures within 60 seconds after turning on.</p> <ol style="list-style-type: none"> <li>1. Connect PIN 3 to PIN 7.</li> <li>2. Disconnect the connection between PIN 3 and PIN 7.</li> <li>3. Connect PIN 3 to PIN 7 again within 3 seconds after the disconnection.</li> <li>4. Disconnect the connection after starting the reboot.</li> </ol> * This performs an initialization processing as same as a serial command <Zrdall>. <p>Note: Be sure to check that all pins are correctly located. If connecting pins mistakenly, it may cause severe damage to the device. With the serial commands &lt;Zrd&gt; and &lt;Zrc&gt;, some settings like the communication settings may not be restored to the factory default. To restore the settings to the factory default, using the &lt;Zrdall&gt; command or the DEFAULT signal of parallel are sometimes required.</p>				Line color	PIN No.	Signal name	Brown	2	24 VDC (Power)	Green	3	Default	Blue	7	0 VDC (Ground)	Red	8	COM_IN
Line color	PIN No.	Signal name																	
Brown	2	24 VDC (Power)																	
Green	3	Default																	
Blue	7	0 VDC (Ground)																	
Red	8	COM_IN																	



<p>How to save read images?</p>	<p>The read images are possible to save with the following procedures.</p> <ul style="list-style-type: none"> <li>• Save images on WebLink. Click <b>Save Current Image</b> button at the right end on the <b>Image Control Toolbar</b> at the upper right on the image area to save the read image to your PC. The file is download to a destination you set with a browser.</li> <li>• Save images to the RAM drive. Images read according to Read Cycle can be saved in the RAM drive on V430. Click Gear icon at the upper right - <b>Image Storage</b> to open <b>Image Save Options</b>, and set the conditions to save images. Click the <b>Advanced</b> button to set other parameters such as <b>Save Image Until</b>. Such saved images can be saved in a PC via FTP. Regarding the method to save images via FTP, refer to "How to access a RAM drive from a PC?". Regarding No. of images savable to the RAM drive, refer to "How many sheets of images can be saved in the RAM drive?". It is initialized when turning off the power because of RAM drive.</li> <li>• Save images to a FTP server. Images read according to Read Cycle can be saved to an FTP server on the network. Click Gear icon at the upper right - <b>Image Storage</b> to open <b>Image Save Options</b>, and set the conditions to save images. Select FTP for the <b>Image Storage Location</b>. By setting the FTP address of the FTP server after that, images can be saved in it.</li> </ul> <p>* Re-reading is not available by using the saved images.</p>														
<p>How to check read characters?</p>	<p>When checking character strings, turn on <b>Matchcode</b> at the left panel on WebLink. Click <b>Mode of Matchcode</b> and register character strings you want to check to <b>Match String Database</b>. Up to 10 strings are registrable to <b>Match String Database</b>.</p>														
<p>What is the smallest size of the readable 2D code?</p>	<p>A 2D code with 2x2 pixels or more in the cell size on an image is readable. This figure is a theoretical value. In practice, test it for the judgment.</p>														
<p>What is the smallest size of the readable barcode?</p>	<p>In ideal, a barcode with the size below is readable. Barcode width: 1 pixel or more Barcode height: 16 pixels or more  These figures are theoretical values. In practice, test it for the judgment.</p>														
<p>What is the method to evaluate the reading stability?</p>	<p>There are two methods.</p> <ul style="list-style-type: none"> <li>• ISO print quality evaluation The ISO print quality evaluation is a function to evaluate the read stability compatible for the ISO standards. For example, use ISO 29158 to evaluate DataMatrix of DPM.</li> </ul> <p>Enable Gear icon - <b>Advanced - Symbol Quality - ISO/IEC 29158 Parameters</b>, which add an evaluation results to the end of a read character strings.</p> <ul style="list-style-type: none"> <li>• Read Rate Mode Operating the Setup Button or performing the Read Rate command makes the device to Rear Rate mode. The operation display LED on the body becomes to indicate the Read Rate and the body is set to a state to output the rate via the serial (RS-232C) communications or TCP communications.</li> </ul>														
<p>What is the number of the maximum readable characters?</p>	<p>MicroHAWK V430-F can read up to the maximum numbers defined each code standard.  For example, although up to 7,089 characters can be input to QR code based on the standard, MicroHAWK V430-F can read the code.</p>														
<p>What is the readable installation distance?</p>	<p>That of MicroHAWK V430-F depends on the cell size (bar width) of a target code too.  The reference values are described on page A-5 to A-6, refer to them. The read range is described, which was possible to read with typical cell size examples for the design readable focal distance per format. * For barcode, a half size of the bar width for readable values of 2D code cell size is a guide.</p>														
<p>How to shorten the read time?</p>	<p>Please consider below.</p> <ul style="list-style-type: none"> <li>• Construct appropriate optical conditions like an image is in focus or having sufficient contrast. (Mount distance, Mount angle, Exposure time)</li> <li>• Limit symbol types for the read target.</li> <li>• Enable the optimization. (Graph icon on the setup screen)</li> <li>• Perform the Window of Interest.</li> </ul>														
<p>What parameters need to be adjusted when a symbol is unable to read?</p>	<p>Adjust the following parameters.</p> <table border="1" data-bbox="454 1682 1318 2002"> <thead> <tr> <th>Symbol state</th> <th>Adjustment</th> </tr> </thead> <tbody> <tr> <td>An image is dark.</td> <td>Adjust <b>Exposure</b> or <b>Gain</b> to bright the image.</td> </tr> <tr> <td>Out of focus.</td> <td>Adjust <b>Focus</b> to make the symbol in focus.</td> </tr> <tr> <td>A cell size is small.</td> <td>Change the mount distance or use a high pixel density and narrow field of view type.</td> </tr> <tr> <td>Noisy background</td> <td>Remove noise with the Morphological Preprocessing. When 5 M type is used, adjust the color filter.</td> </tr> <tr> <td>The read time takes much time.</td> <td>Set <b>Timeout</b> longer.</td> </tr> <tr> <td>The lighting is reflected.</td> <td>Tilt the lighting by approx. 15 degrees to reduce the reflection. Or, try to use the optional Polarizer (V430-AF12) and the Diffuser (V430-AF11).</td> </tr> </tbody> </table>	Symbol state	Adjustment	An image is dark.	Adjust <b>Exposure</b> or <b>Gain</b> to bright the image.	Out of focus.	Adjust <b>Focus</b> to make the symbol in focus.	A cell size is small.	Change the mount distance or use a high pixel density and narrow field of view type.	Noisy background	Remove noise with the Morphological Preprocessing. When 5 M type is used, adjust the color filter.	The read time takes much time.	Set <b>Timeout</b> longer.	The lighting is reflected.	Tilt the lighting by approx. 15 degrees to reduce the reflection. Or, try to use the optional Polarizer (V430-AF12) and the Diffuser (V430-AF11).
Symbol state	Adjustment														
An image is dark.	Adjust <b>Exposure</b> or <b>Gain</b> to bright the image.														
Out of focus.	Adjust <b>Focus</b> to make the symbol in focus.														
A cell size is small.	Change the mount distance or use a high pixel density and narrow field of view type.														
Noisy background	Remove noise with the Morphological Preprocessing. When 5 M type is used, adjust the color filter.														
The read time takes much time.	Set <b>Timeout</b> longer.														
The lighting is reflected.	Tilt the lighting by approx. 15 degrees to reduce the reflection. Or, try to use the optional Polarizer (V430-AF12) and the Diffuser (V430-AF11).														

<p>Is it possible to function the autofocus while reading?</p>	<p>The autofocus while reading can be enabled when the Read Cycle is set to <b>Continuous Read</b> or <b>Continuous Read Auto</b>.                  Since the autofocus adjustment needs several seconds, use the Configuration Database function when switching the mount distances that are predetermined.                  Related Q&amp;A: <i>Can serial commands calibrate brightness or focus?</i></p>
<p>What is the number of the maximum characters for Match String Database?</p>	<p>It is 3,000 characters.                  It is divided by the number of registrations, so it varies depending on the number of registrations.                  When the number of registrations is one, it can register up to 3,000 characters.                  When the number of registrations is ten, each registration can register up to 300 characters.                  Related Q&amp;A: <i>What is the number of the maximum readable characters?</i></p>
<p>How to change Match String externally?</p>	<p>Use &lt;K231&gt; command.                  Command format: &lt;K231, index, master symbol data&gt;                  Example:                  When setting ABC to the first Match String Database:                  &lt;K231, 1, ABC&gt;</p>
<p>How to enable the External Trigger rather than Continuous Read?</p>	<p>Set the Trigger Mode except for <b>Continuous Read</b>. Refer to the following instruction.                  Select Gear icon - <b>Advanced - Read Cycle - Trigger - Mode - External Edge or Serial Data and Edge</b>.</p>
<p>How can I confirm the OK/NG Read result over EtherNet/IP?</p>	<p>The method differs according to the selected input assembly.</p> <ul style="list-style-type: none"> <li>• When using a Small (100) assembly;                      First determine whether the Output String (DECODE DATA STRING) is <b>NOREAD</b> (default).</li> <li>• When using a Big (101) assembly;                      There is a way to verify the <b>External Output Status</b> OUTPUT bit.                      Please note that the <b>External Output Status</b> is dependent on the Output condition setting for the Parallel I/O OUTPUT signal. The default setting is ON when there is a Read Fail.</li> <li>• When an assembly after MXL/SLC (102) is selected;                      You can verify the <b>Read Cycle Pass, Read Cycle Fail</b> bit status in <b>Device Status</b>. The <b>Read Cycle Pass, Read Cycle Fail</b> bit is OFF during a READ cycle and is updated when <b>Data Is Ready</b> is ON.</li> </ul>

EtherNet/IP data output timing

The timing signal indicating when the output data is stored in the data memory of the PLC varies depending on the selected assembly.

- When using the Small (100) assembly, there is no applicable data output timing signal
  - When using the Big (101) assembly, the timing of data output is when **Device Status - In Read Cycle** bit changes from ON to OFF.
  - When MXL/SLC (102) or later assembly is selected, Output is at the timing when the **Data Status Ready** bit of **Device Status** turns ON.
- When using the Small (100) assembly, there is no applicable data output timing signal.

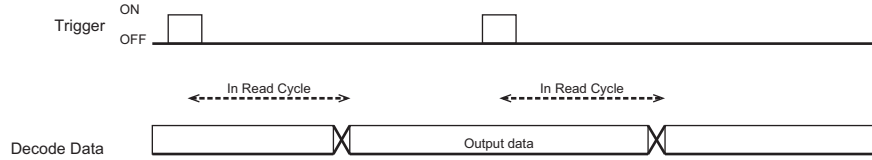

· When using the Big (101) assembly, the timing of data output is when **Device Status - In Read Cycle** bit changes from ON to OFF.

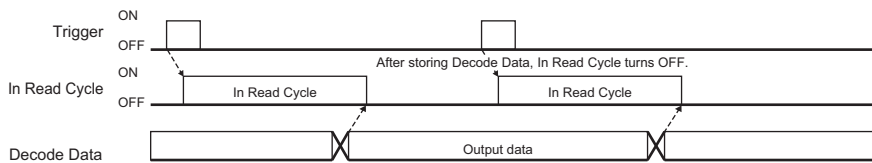

· When MXL/SLC (102) or later assembly is selected, Output is at the timing when the **Data Status Ready** bit of **Device Status** turns ON.

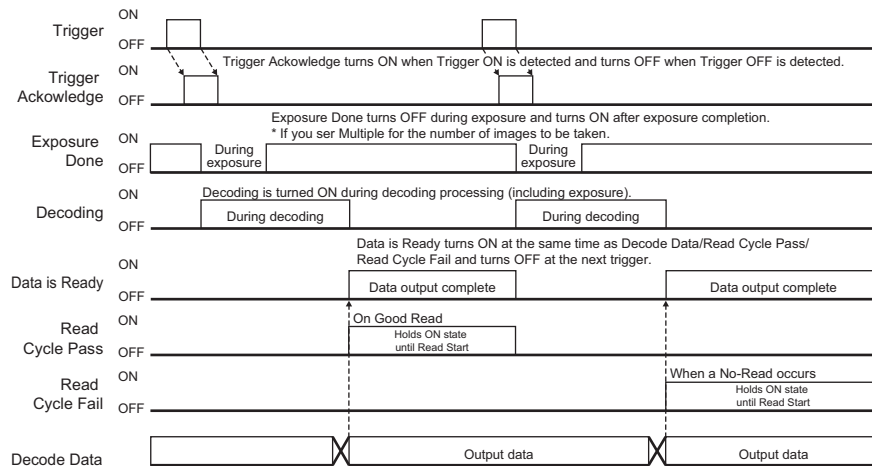







# Appendix S - Optics and Lighting Accessory Kit Installation



This section contains instructions for how to install the optical accessories on a MicroHAWK V320-F, V330-F, V420-F, and V430-F.

---

<b>S-1 Optics and Lighting Accessories. ....</b>	<b>S-2</b>
--	------------

# S-1 Optics and Lighting Accessories

## MicroHAWK Optics and Lighting Accessory List

This section contains instructions for how to install the optical accessories on a MicroHAWK ID/MV-20, V/F320-F, V/F330-F, V/F420-F and V/F430-F.

### Contents

1. MicroHAWK ID/MV-20 Diffuser and Polarizer Kit Installation
2. MicroHAWK V/F3XX-F Diffuser and Polarizer Kit Installation
3. MicroHAWK V/F4XX-F Window and LED Kit Installation
4. MicroHAWK V/F4XX-F With Ring Light Window and LED Kit Installation
5. MicroHAWK V/F4XX-F Polarizer Kit Installation

Type	Description	Kit Part Number
ID/MV-20 Window Kits	Kit, Diffuser, MicroHAWK ID/MV-20	98-9000077-01
	Kit, Polarizer, MicroHAWK ID/MV-20	98-9000062-01
V/F330-F and V/F320-F Window Kits	Kit, Diffuser, MicroHAWK V/F330	V330-AF1
	Kit, Polarizer, MicroHAWK V/F330	V330-AF2
V/F430-F and V/F420-F Window Kits	Kit, Window, V/F4XX	V430-AF10*
	Kit, Diffuser, V/F4XX	V430-AF11*
	Kit, Polarizer, V/F4XX	V430-AF12*
	Kit, YAG Filter, V/F4XX	V430-AF4
	Kit, ESD Window, V/F4XX	V430-AF5
	Kit, Red Filter, V/F4XX	V430-AF6
	Kit, Blue Filter, V/F4XX	V430-AF7
V/F430-F and V/F420-F LED Kits	Kit, Red LED, V/F4XX	V430-ALR
	Kit, White LED, V/F4XX	V430-ALW
	Kit, Blue LED, V/F4XX	V430-ALB
	Kit, IR LED, V/F4XX	V430-ALI
V/F430-F With Ring Light Window Kits	Kit, Window, RING LT, F/V430	V430-AF0R
	Kit, Diffuser, RING LT, F/V430	V430-AF1R
	Kit, Polarizer, RING LT, F/V430	V430-AF2R
V/F430-F With Ring Light LED Kits	Kit, Red LED, RING LT, F/V430	V430-ALRR
	Kit, White LED, RING LT, F/V430	V430-ALWR
	Kit, Blue LED, RING LT, F/V430	V430-ALBR
	Kit, IR LED, RING LT, F/V430	V430-ALIR

\* Note: V430-AF10, AF11, and AF12 are used for MicroHAWK V/F4X0-FXXXXXXX-XXX cameras in this datasheet. The prior generation MicroHAWK V430-FXXXXXXX code reader uses part numbers V430-AF0, AF1, and AF2. Please select the correct accessory from the table based on your camera part number format.

Accessory	Prior V430-FXXXXXXX Code Reader	New V/F4X0-FXXXXXXX-XXX Code Reader and Smart Camera
Front Window Installation Kit	V430-AF0	V430-AF10
Diffuser Installation Kit	V430-AF1	V430-AF11
Polarizer Installation Kit	V430-AF2	V430-AF12

## MicroHAWK ID/MV-20 Diffuser and Polarizer Kit Installation

### Diffuser Kit Hardware, MicroHAWK ID/MV-20

Qty	Description	Kit Part Number
1	Kit, Diffuser, MicroHAWK ID/MV-20	98-9000077-01

### Diffuser Kit Installation, MicroHAWK ID-20/MV-20

**Step 1:** Peel the protective liner from the adhesive on the diffuser.

**Step 2:** Rest the narrow edge of the diffuser on the bottom edge of the window opening at an angle as shown below.

**Step 3:** Center the diffuser left-to-right in the window opening.

**Step 4:** Affix the diffuser to the window.

**Step 5:** Run your finger over the surface of the diffuser using light pressure to complete the bond.

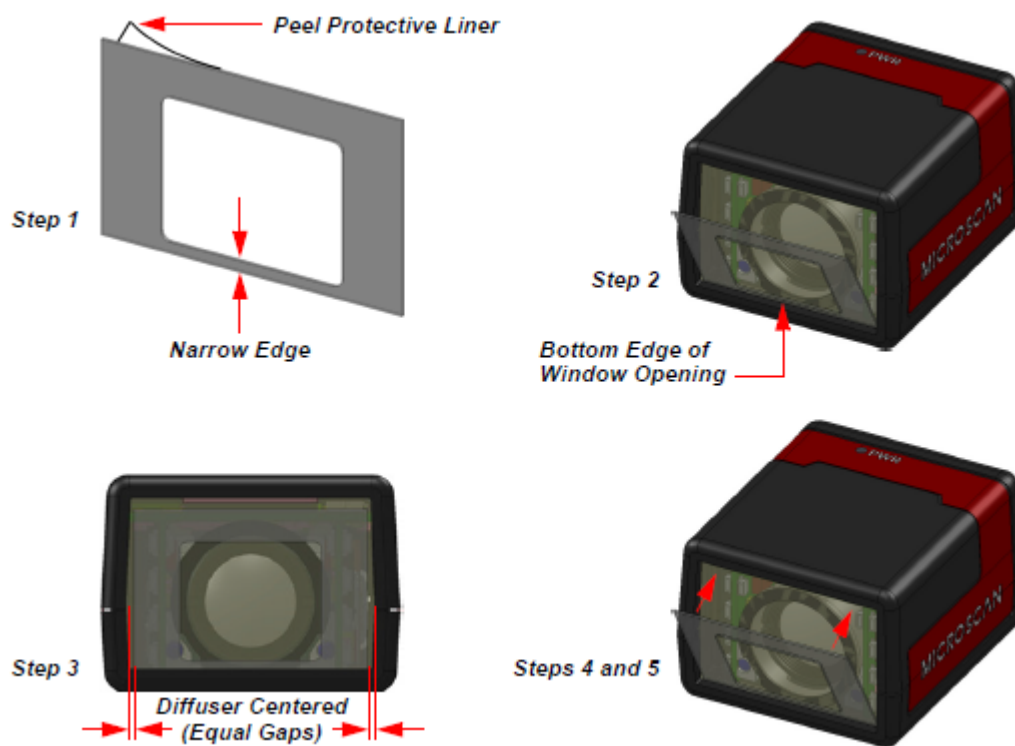

### Polarizer Kit Hardware, MicroHAWK ID-20/MV-20

Qty	Description	Kit Part Number
1	Kit, Polarizer, MicroHAWK ID/MV-20	98-9000062-01

### Polarizer Kit Installation, MicroHAWK ID-20/MV-20

**Step 1:** Peel the protective liner from adhesive on the polarizer.

**Step 2:** Rest the narrow edge of the polarizer on the bottom edge of the window opening at an angle as shown below.

**Step 3:** Center the polarizer left-to-right in the window opening.

**Step 4:** Affix the polarizer to the window.

**Step 5:** Run your finger over the surface of the polarizer using light pressure to complete the bond.

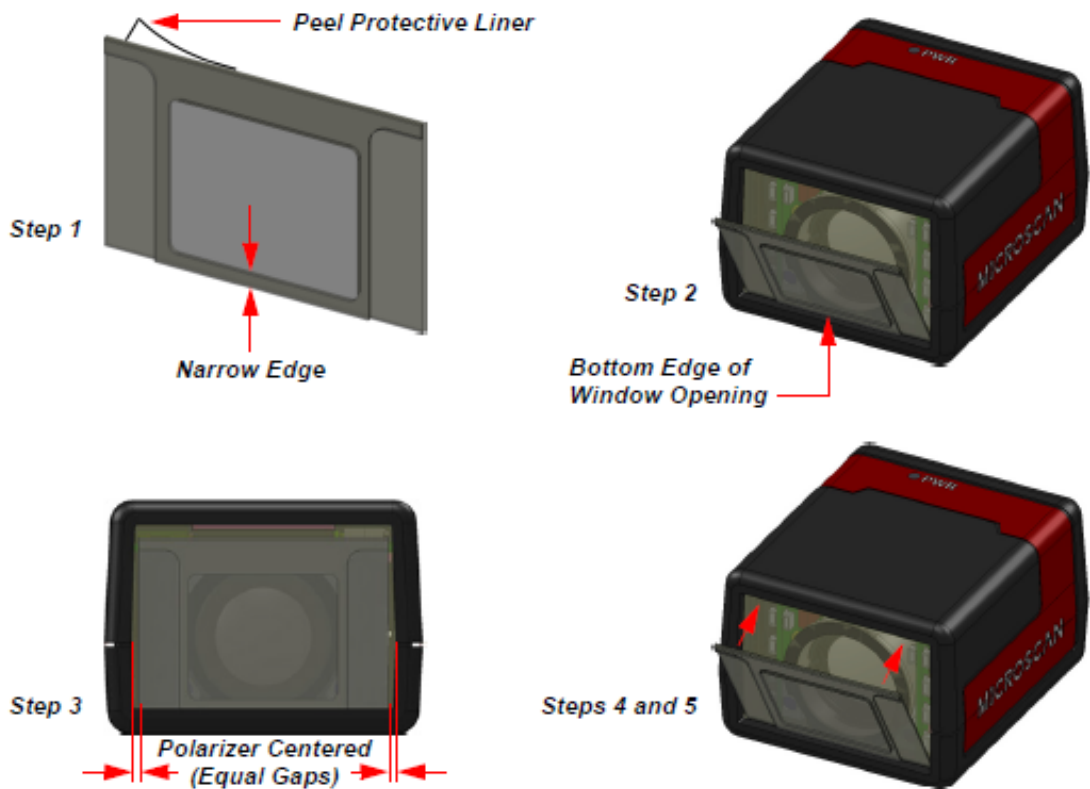

## MicroHAWK V/F3XX-F Diffuser and Polarizer Kit Installation

Qty	Description	Kit Part Number
1	Kit, Diffuser, MicroHAWK ID/MV-20	V330-AF1

### Diffuser Kit Installation, MicroHAWK V/F330 and V/F320

**Step 1:** Follow same steps as above for the ID/MV-20.

**Note:** Take care to align the Diffuser so that the narrow edge is at bottom, that there is an equal gap laterally, and that the bottom edge is aligned with bottom edge of window.



### Polarizer Kit Hardware, MicroHAWK V/F330-F and V/F320-F

Qty	Description	Kit Part Number
1	Kit, Polarizer, MicroHAWK V/F330	V330-AF2

### Polarizer Kit Installation, MicroHAWK V/F330 and V/F320

**Step 1:** Follow same steps as above for the ID/MV-20

**Note:** Take care to align the Polarizer so that the narrow edge is at bottom, that there is an equal gap laterally, and that the bottom edge is aligned with bottom edge of window.



## MicroHAWK V/F4XX-F Window and LED Kit Installation

### Window Kit Hardware, MicroHAWK V/F430-F and V/F420-F

Qty	Description	Kit Part Number
1	Window, Diffuser, Polarizer or Filter Kits (included)	V430-AF10 (Window) V430-AF11 (Diffuser) V430-AF12 (Polarizer) V430-AF4 (YAG Filter) V430-AF5 (ESD Window) V430-AF6 (Red Filter) V430-AF7 (Blue Filter)
4	0-80 Phillips-Head Screws (included)	
1	Gasket (included)	
1	Phillips Torque Wrench (not included)	N/A

### LED Kit Hardware, MicroHAWK V/F430-F and V/F420-F

Qty	Description	Kit Part Number
1	LED Board Kits (included)	V430-ALR (Red LEDs) V430-ALW (White LEDs) V430-ALB (Blue LEDs) V430-ALI (IR LEDs)
4	0-80 Phillips-Head Screws (included)	
1	Gasket (included)	
1	Phillips Torque Wrench (not included)	N/A
1	Fine-Tip Tweezers (not included)	N/A

### Window Removal, MicroHAWK V/F4XX-F

**Step 1:** Disconnect power from the camera.

**Step 2:** Remove the four screws from the front window of the camera.

**Step 3:** Remove the front window and gasket.

**Note:** If installing a window accessory only, skip to **Step 8**.

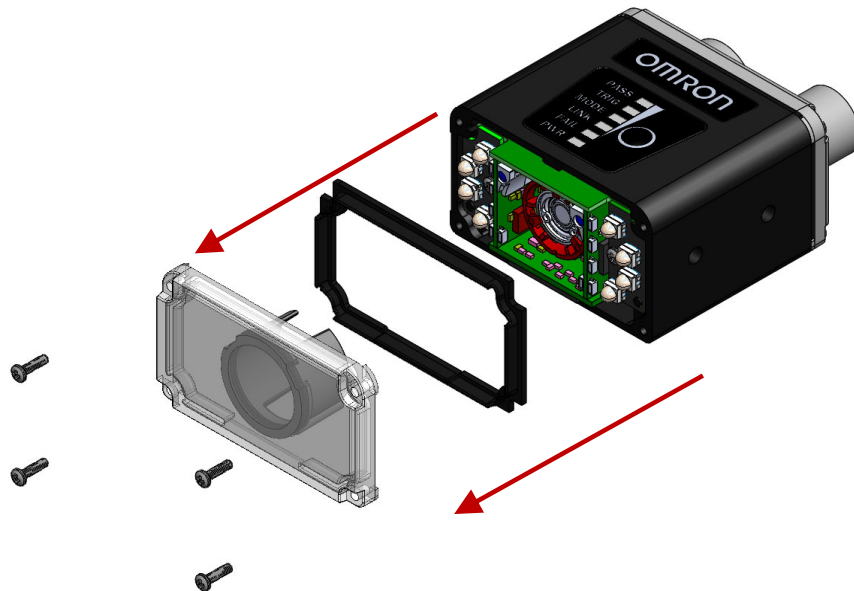

## Outer LED Removal, MicroHAWK V/F4XX-F

**Note:** If installing an LED accessory only, skip to **Step 6**.

**Step 4:** Remove the two screws from the LED boards.

**Step 5:** Unplug the LED boards from the camera.

**Note:** The LED boards have a connector interface. Gently pry the top of each LED board from the main board using fine-tipped tweezers or an equivalent tool. Use caution not to contact the LEDs as they may become damaged.

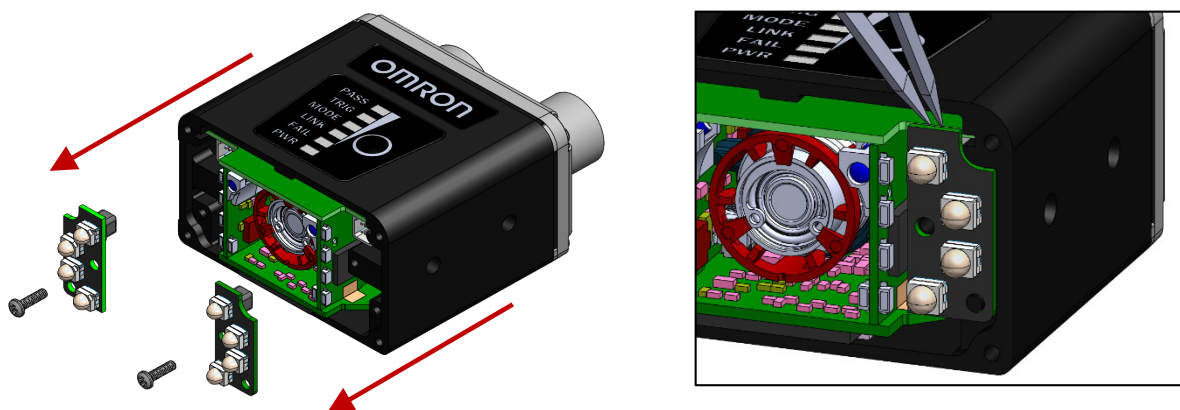

## Outer LED Installation, MicroHAWK V/F4XX-F

**Step 6:** Plug the LED boards into the main board. Use caution not to touch the LEDs, as they may be damaged by contact.

**Step 7:** Secure the LED boards in place using the screws provided. Do not over-tighten the screws.

(1.0 in./lbs. (0.11 nm max.))

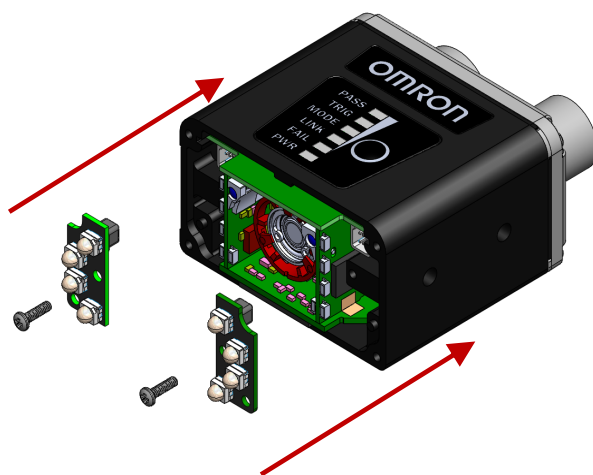

## Window Installation, MicroHAWK V/F4XX-F

**Step 8:** Install the gasket onto the camera. Ensure that the gasket is properly seated in place and is covering all sealing surfaces.

**Step 9:** Install the window (or window accessory) onto the camera.

**Step 10:** Secure the window in place using the screws provided. Do not over-tighten the screws.  
(1.0 in./lbs. (0.11 nm max.)

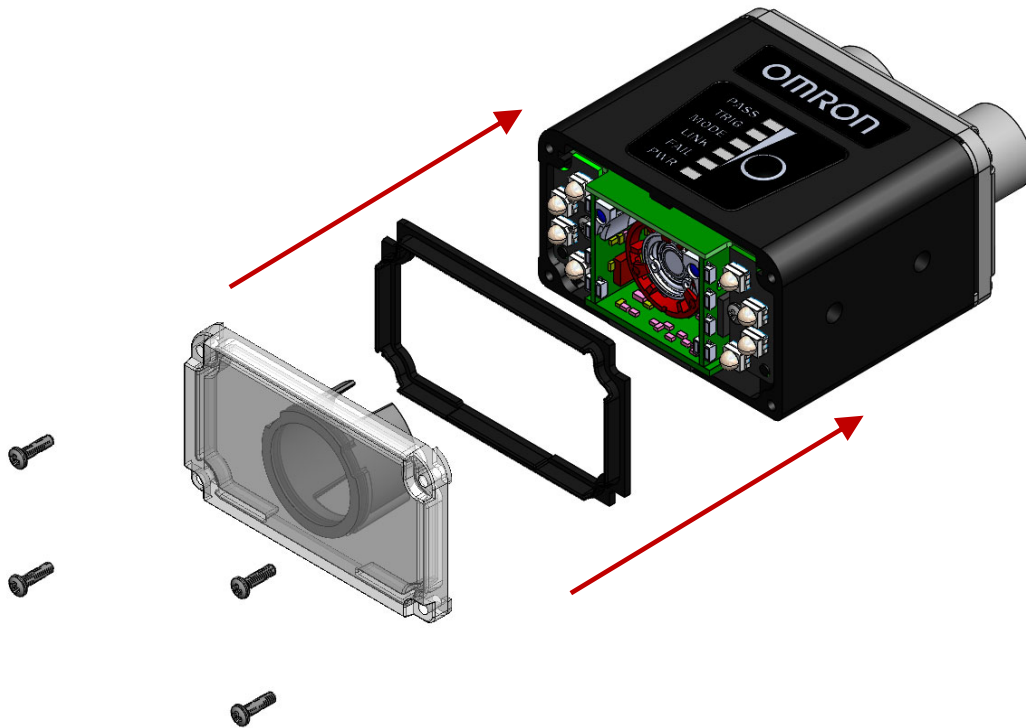



## MicroHAWK V/F430-F with Ring Light Window and LED Installation

### Window Kit Hardware, MicroHAWK V/F430-F with Ring Light

Qty	Description	Part Number
1	Window Assembly (included)	V430-AF0R (Window)
1	Window Gasket (included)	V430-AF1R (Diffuser)
2	#2-56 X 3/8" Phillips Flat Head Screw (included)	
4	#4-40 X 1/4" Phillips Pan Head Screw w/ Lock Washers (included)	
1	Phillips Torque Wrench (not included)	N/A

### LED Kit Hardware, MicroHAWK V/F430-F with Ring Light

Qty	Description	Part Number
1	LED Board Kits (included)	V430-ALR (Red LEDs)
1	Window Gasket (included)	V430-ALW (White LEDs)
2	#2-56 X 3/8" Phillips Flat Head Screw (included)	V430-ALB (Blue LEDs)
4	#4-40 X 1/4" Phillips Pan Head Screw w/ Lock Washers (included)	V430-ALI (IR LEDs)
1	Phillips Torque Wrench (not included)	N/A

### Window Removal, MicroHAWK V/F430-F with Ring Light

**Step 1:** Disconnect power from the camera.

**Step 2:** Unscrew the four #4-40 pan head screws that secure the window.

**Step 3:** Remove the gasket from around the window frame.

**Step 4:** If not replacing the LED Board, go to step 8. If replacing the LED Board, unscrew the two #2-56 flat head screws that secure the diffuser.

**Note:** Do not touch the electronics or lens, as this may cause damage.

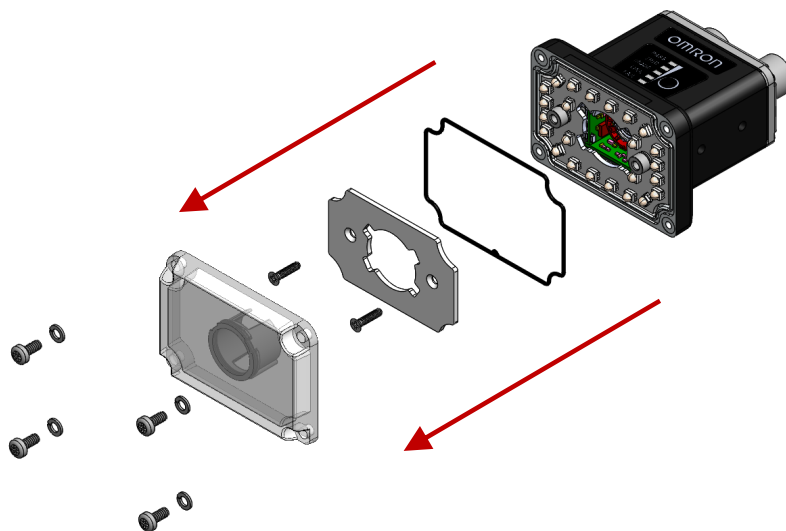

## Outer LED Removal, MicroHAWK V/F430-F Ring Light

**Step 5:** Unplug the LED board from the camera.

**Note:** The LED board has two connectors on the left and right of the camera front face. Gently pry the LED board from the camera using fine-tipped tweezers or an equivalent tool. Use caution not to contact the LEDs as they may become damaged.

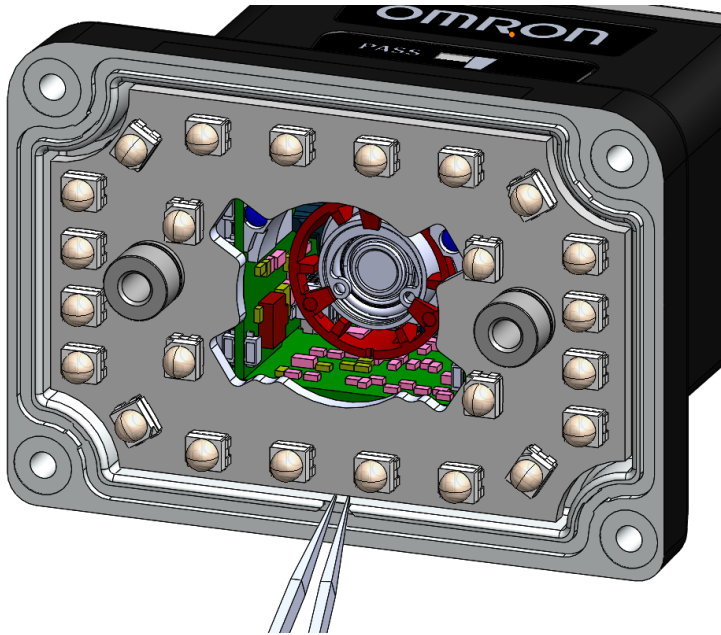

## Outer LED Installation, MicroHAWK V/F430-F with Ring Light

**Step 6:** Plug the new LED board into the camera connectors. Use caution not to touch the LEDs, as they may be damaged by contact.

## Window Installation, MicroHAWK V/F430-F with Ring Light

**Step 7:** Reinstall the new #2-56 flat head screws through the diffuser into the camera PEM nuts. Do not overtighten the screws (1.9 in-lbs. (0.21 Nm) max)

**Step 8:** Install the new gasket, ensuring that it is fully constrained within the gasket groove.

**Step 9:** Place the window on the front of the unit and secure with the new #4-40 pan head screws and lock washers. Do not overtighten the screws (2.9 in-lbs. (0.33 Nm) max).

**Step 10:** Inspect the gasket to ensure it did not come out of the groove in the window frame.

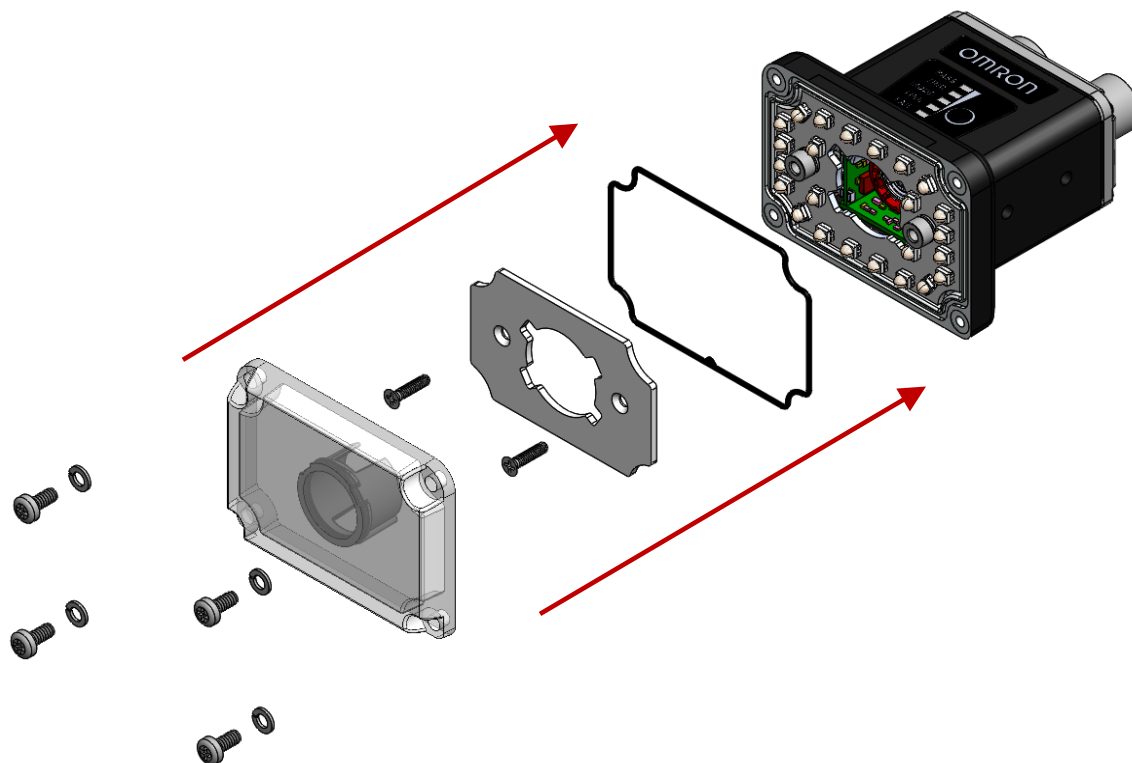

## MicroHAWK V/F430-F with Ring Light Polarizer Kit Installation

### Polarizer Kit Hardware, MicroHAWK V/F430-F with Ring Light

Qty	Description	Kit Part Number
1	Window Assembly (included)	V430-AF2R (Polarizer)
1	Window Gasket (included)	
2	#2-56 X 3/8" Phillips Flat Head Screw (included)	
4	#4-40 X 1/4" Phillips Pan Head Screw w/ Lock Washers (included)	
1	Phillips Torque Wrench (not included)	N/A

### Window Removal, MicroHAWK V/F430-F with Ring Light

**Step 1:** Disconnect power from the camera.

**Step 2:** Unscrew the four #4-40 pan head screws that secure the window.

**Step 3:** Remove the gasket from around the window frame.

**Step 4:** Remove the two #2-56 flat head screws. Remove and dispose of the diffuser.

**Note:** Do not touch the electronics or lens, as this may cause damage.

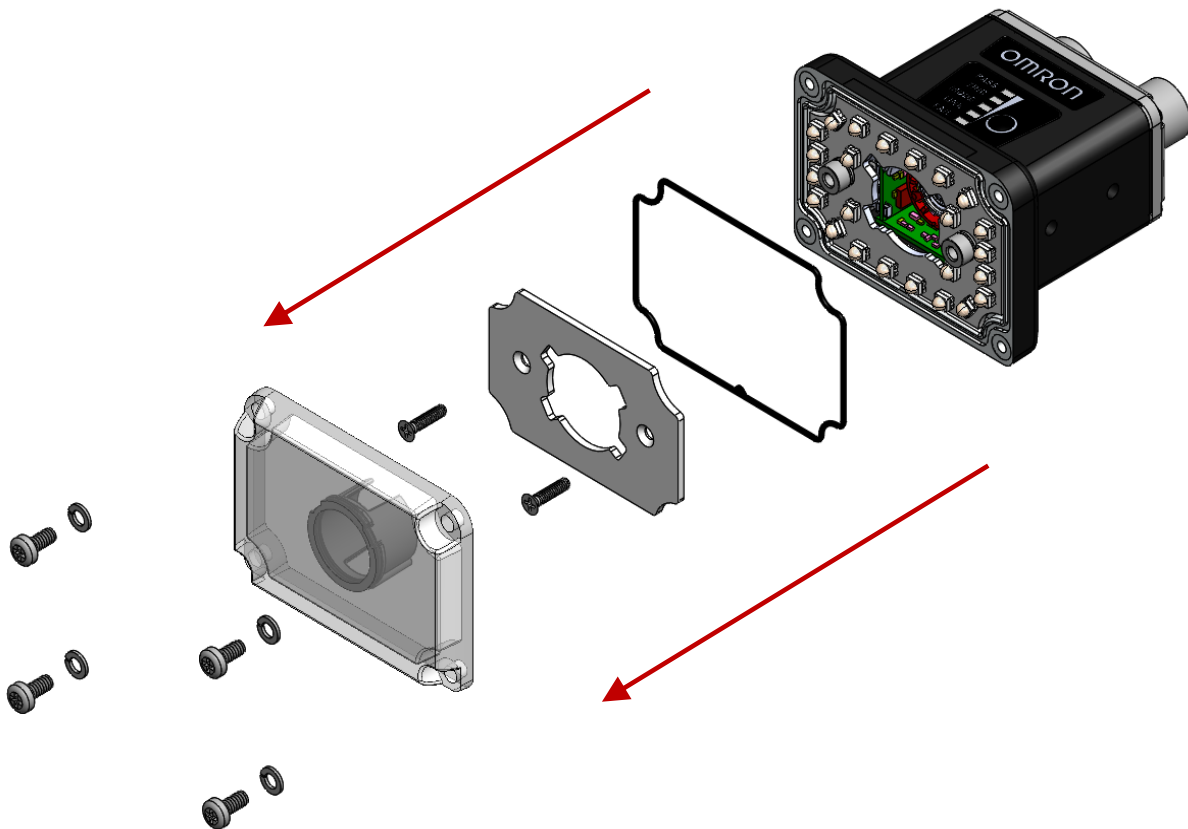

## Polarizer Window Installation, MicroHAWK V/F430-F with Ring Light

**Step 5:** Reinstall the new #2-56 flat head screws in the LED board PEM nuts without replacing the diffuser. Do not overtighten the screws (1.9 in-lbs. (0.21 Nm) max)

**Step 6:** Install the new gasket, ensuring that it is fully constrained within the gasket groove.

**Step 7:** Place the polarizer window on the front of the unit and secure with the new #4-40 pan head screws and lock washers. Do not overtighten the screws (2.9 in-lbs. (0.33 Nm) max).

**Step 8:** Inspect the gasket to ensure it did not come out of the groove in the window frame.

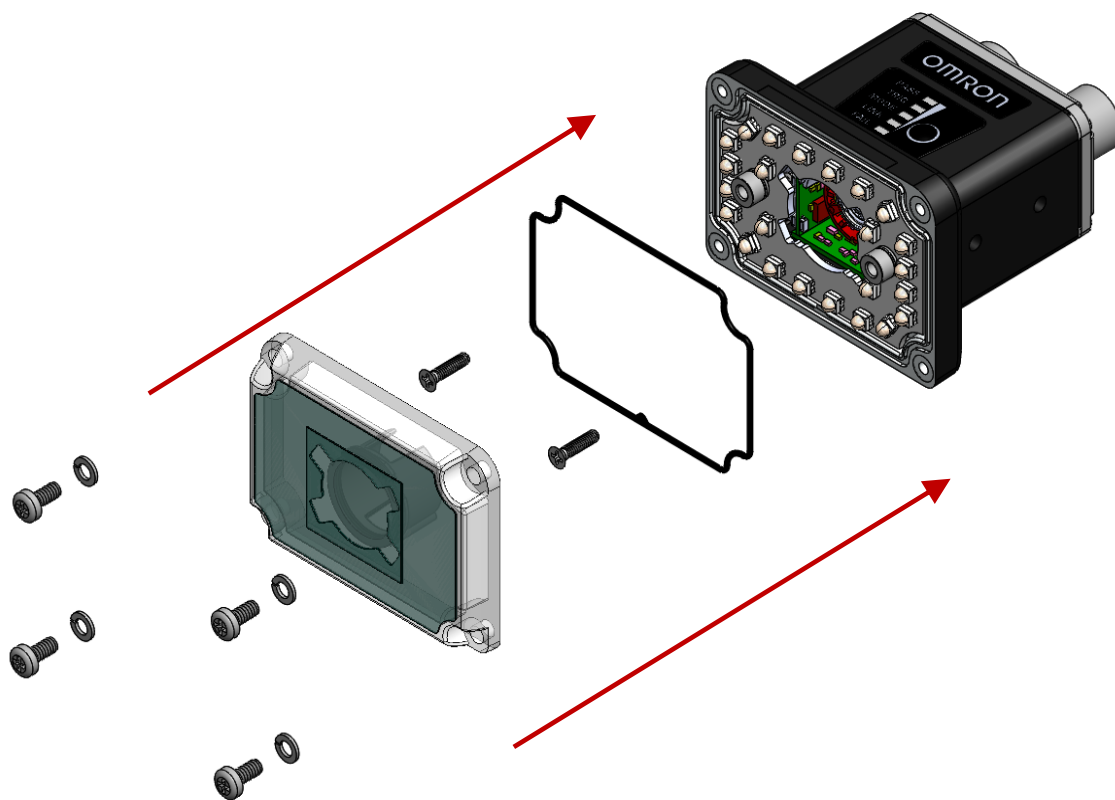

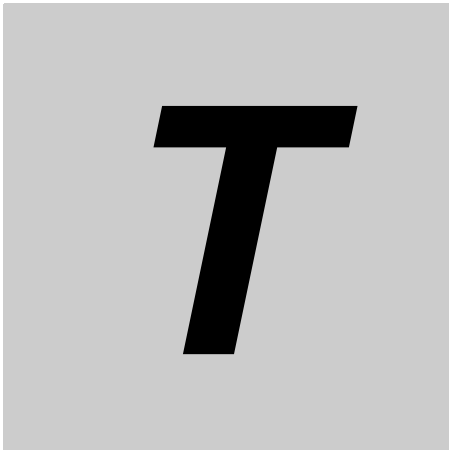

# TCP/UDP and General Port Usage

This section lists the ports used by MicroHAWK readers for communication.

---

T-1 Ports..... T-2

# T-1 Ports

---

The following table lists the ports used by MicroHAWK F-Series Smart Cameras for communication.

Name	Protocol	Port Number
RPC	TCP	49059
I/O	TCP	49049
PIC/LIVE	TCP	49050
REPORT	TCP	49200
REPORTCONTROL	TCP	49202
PARTQ	TCP	49201
KEEPALIVE	TCP	49079
Serial TCP#1	TCP	49211
Serial TCP#2	TCP	49212
Serial TCP#3	TCP	49213
Serial TCP#4	TCP	49214
UDP BROADCAST	UDP	49497
UDP COMMAND	UDP	49496
FTP	TCP	21
TELNET	TCP	23
HTTP (Web Server Port) When Running on PC	HTTP	8080
HTTP (Web Server Port) When Running Smart Camera	HTTP	80
HAWK MV-4000 Monitor Process	HTTP	8088
HAWK MV-4000 Web Server Port	HTTP	8081
EIP Explicit Messaging	TCP	44818
EIP Implicit Messaging	UDP	2222
PROFINET	UDP	34964

**OMRON Corporation** Industrial Automation Company  
Kyoto, JAPAN

Contact: [www.ia.omron.com](http://www.ia.omron.com)

**Regional Headquarters**

**OMRON EUROPE B.V.**

Wegalaan 67-69, 2132 JD Hoofddorp  
The Netherlands  
Tel: (31)2356-81-300/Fax: (31)2356-81-388

**OMRON ELECTRONICS LLC**

2895 Greenspoint Parkway, Suite 200  
Hoffman Estates, IL 60169 U.S.A.  
Tel: (1) 847-843-7900/Fax: (1) 847-843-7787

**OMRON ASIA PACIFIC PTE. LTD.**

No. 438A Alexandra Road # 05-05/08 (Lobby 2),  
Alexandra Technopark,  
Singapore 119967  
Tel: (65) 6835-3011/Fax: (65) 6835-2711

**OMRON (CHINA) CO., LTD.**

Room 2211, Bank of China Tower,  
200 Yin Cheng Zhong Road,  
PuDong New Area, Shanghai, 200120, China  
Tel: (86) 21-5037-2222/Fax: (86) 21-5037-2200

**Authorized Distributor:**

© OMRON Corporation 2022 All Rights Reserved.  
In the interest of product improvement,  
specifications are subject to change without notice.

Cat. No. **Z432-E-06 (84-9000400-02-E)**

1122 (1119)