

Machine Automation Controller

NX-series

CPU Unit

**FINS Function
User's Manual**

NX701-1720

NX701-1620

NX502-1□□□

NX102-12□□

NX102-11□□

NX102-10□□

NX102-90□□

NOTE

1. All rights reserved. No part of this publication may be reproduced, stored in a retrieval system, or transmitted, in any form, or by any means, mechanical, electronic, photocopying, recording, or otherwise, without the prior written permission of OMRON.
2. No patent liability is assumed with respect to the use of the information contained herein. Moreover, because OMRON is constantly striving to improve its high-quality products, the information contained in this manual is subject to change without notice.
3. Every precaution has been taken in the preparation of this manual. Nevertheless, OMRON assumes no responsibility for errors or omissions. Neither is any liability assumed for damages resulting from the use of the information contained in this publication.

Trademarks

- Sysmac and SYSMAC are trademarks or registered trademarks of OMRON Corporation in Japan and other countries for OMRON factory automation products.
- Microsoft, Windows, Excel, Visual Basic, and Microsoft Edge are either registered trademarks or trademarks of Microsoft Corporation in the United States and other countries.
- EtherCAT® is registered trademark and patented technology, licensed by Beckhoff Automation GmbH, Germany.
- ODVA, CIP, CompoNet, DeviceNet, and EtherNet/IP are trademarks of ODVA.
- The SD and SDHC logos are trademarks of SD-3C, LLC. 

Other company names and product names in this document are the trademarks or registered trademarks of their respective companies.

Copyrights

- Microsoft product screen shots used with permission from Microsoft.
- This product incorporates certain third party software. The license and copyright information associated with this software is available at http://www.fa.omron.co.jp/nj_info_e/.

Introduction

Thank you for purchasing an NX-series CPU Unit.

This manual contains information that is necessary to use the NX-series CPU Unit. Please read this manual and make sure you understand the functionality and performance of the NX-series CPU Unit before you attempt to use it in a control system.

Keep this manual in a safe place where it will be available for reference during operation.

Intended Audience

This manual is intended for the following personnel, who must also have knowledge of electrical systems (an electrical engineer or the equivalent).

- Personnel in charge of introducing FA systems.
- Personnel in charge of designing FA systems.
- Personnel in charge of installing and maintaining FA systems.
- Personnel in charge of managing FA systems and facilities.

For programming, this manual is intended for personnel who understand the programming language specifications in international standard IEC 61131-3 or Japanese standard JIS B 3503.

Applicable Products

This manual covers the following products.

NX-series CPU Unit

- NX701-1720
- NX701-1620
- NX502-1□□□
- NX102-12□□
- NX102-11□□
- NX102-10□□
- NX102-90□□

Part of the specifications and restrictions for the CPU Units are given in other manuals. Refer to *Relevant Manuals* on page 2 and *Related Manuals* on page 17.

Relevant Manuals

The following table provides the relevant manuals for the NX-series CPU Units. Read all of the manuals that are relevant to your system configuration and application before you use the NX-series CPU Unit.

Most operations are performed from the Sysmac Studio Automation Software. Refer to the *Sysmac Studio Version 1 Operation Manual (Cat. No. W504)* for information on the Sysmac Studio.

Purpose of use	Manual											
	Basic information				N/UNIX-series Instructions Reference Manual	N/UNIX-series Motion Control User's Manual	N/UNIX-series Motion Control Instructions Reference Manual	N/UNIX-series Built-in EtherCAT Port User's Manual	N/UNIX-series CPU Unit	N/UNIX-series EtherNet/IP Port User's Manual	N/UNIX-series CPU Unit OPC UA User's Manual	N/UNIX-series CPU Unit FINS Function User's Manual
	N/UNIX-series Hardware User's Manual	NX-series NX502 CPU Unit Hardware User's Manual	NX-series NX102 CPU Unit Hardware User's Manual	Software User's Manual								
Introduction to NX701 Controller	○											
Introduction to NX502 Controller		○										
Introduction to NX102 Controller			○									
Setting devices and hardware												
Using motion control			○			○						
Using EtherCAT	○	○	○				○					
Using EtherNet/IP									○			
Software settings												
Using motion control						○						
Using EtherCAT							○					
Using EtherNet/IP				○					○			
Using OPC UA										○		
Using FINS											○	
Using the database connection service												○
Writing the user program												
Using motion control						○	○					
Using EtherCAT								○				
Using EtherNet/IP									○			
Using OPC UA				○						○		
Using FINS					○						○	
Using the database connection service												○
Programming error processing												○

Purpose of use	Manual													
	Basic information													
	NJ/NX-series Hardware User's Manual	NX-series CPU Unit Hardware User's Manual	NX-series NX502 CPU Unit Hardware User's Manual	NX-series NX102 CPU Unit Hardware User's Manual	NJ/NX-series CPU Unit Software User's Manual	NJ/NX-series CPU Unit Instructions Reference Manual	NJ/NX-series Motion Control User's Manual	NJ/NX-series Motion Control Instructions Reference Manual	NJ/NX-series Built-in EtherCAT Port User's Manual	NJ/NX-series CPU Unit Built-in EtherNet/IP Port User's Manual	NJ/NX-series CPU Unit OPC UA User's Manual	NJ/NX-series CPU Unit FINS Function User's Manual	NJ/NX-series Troubleshooting Manual	NJ/NX-series Database Connection CPU Units User's Manual
Testing operation and debugging														
Using motion control							○							
Using EtherCAT								○						
Using EtherNet/IP					○				○					
Using OPC UA										○				
Using FINS											○			
Using the database connection service													○	
Learning about error management functions and corrections of problems *1										△	△	△	△	○
Maintenance														
Using motion control	○	○	○				○							
Using EtherCAT								○						
Using EtherNet/IP									○					

*1. Refer to the *NJ/NX-series Troubleshooting Manual (Cat. No. W503)* for the error management concepts and the error items. However, refer to the manuals that are indicated with triangles for details on errors corresponding to the products with the manuals that are indicated with triangles.

Terms and Conditions Agreement

Warranty, Limitations of Liability

Warranties

● Exclusive Warranty

Omron's exclusive warranty is that the Products will be free from defects in materials and workmanship for a period of twelve months from the date of sale by Omron (or such other period expressed in writing by Omron). Omron disclaims all other warranties, express or implied.

● Limitations

OMRON MAKES NO WARRANTY OR REPRESENTATION, EXPRESS OR IMPLIED, ABOUT NON-INFRINGEMENT, MERCHANTABILITY OR FITNESS FOR A PARTICULAR PURPOSE OF THE PRODUCTS. BUYER ACKNOWLEDGES THAT IT ALONE HAS DETERMINED THAT THE PRODUCTS WILL SUITABLY MEET THE REQUIREMENTS OF THEIR INTENDED USE.

Omron further disclaims all warranties and responsibility of any type for claims or expenses based on infringement by the Products or otherwise of any intellectual property right.

● Buyer Remedy

Omron's sole obligation hereunder shall be, at Omron's election, to (i) replace (in the form originally shipped with Buyer responsible for labor charges for removal or replacement thereof) the non-complying Product, (ii) repair the non-complying Product, or (iii) repay or credit Buyer an amount equal to the purchase price of the non-complying Product; provided that in no event shall Omron be responsible for warranty, repair, indemnity or any other claims or expenses regarding the Products unless Omron's analysis confirms that the Products were properly handled, stored, installed and maintained and not subject to contamination, abuse, misuse or inappropriate modification. Return of any Products by Buyer must be approved in writing by Omron before shipment. Omron Companies shall not be liable for the suitability or unsuitability or the results from the use of Products in combination with any electrical or electronic components, circuits, system assemblies or any other materials or substances or environments. Any advice, recommendations or information given orally or in writing, are not to be construed as an amendment or addition to the above warranty.

See <https://www.omron.com/global/> or contact your Omron representative for published information.

Limitation on Liability; Etc

OMRON COMPANIES SHALL NOT BE LIABLE FOR SPECIAL, INDIRECT, INCIDENTAL, OR CONSEQUENTIAL DAMAGES, LOSS OF PROFITS OR PRODUCTION OR COMMERCIAL LOSS IN ANY

WAY CONNECTED WITH THE PRODUCTS, WHETHER SUCH CLAIM IS BASED IN CONTRACT, WARRANTY, NEGLIGENCE OR STRICT LIABILITY.

Further, in no event shall liability of Omron Companies exceed the individual price of the Product on which liability is asserted.

Application Considerations

Suitability of Use

Omron Companies shall not be responsible for conformity with any standards, codes or regulations which apply to the combination of the Product in the Buyer's application or use of the Product. At Buyer's request, Omron will provide applicable third party certification documents identifying ratings and limitations of use which apply to the Product. This information by itself is not sufficient for a complete determination of the suitability of the Product in combination with the end product, machine, system, or other application or use. Buyer shall be solely responsible for determining appropriateness of the particular Product with respect to Buyer's application, product or system. Buyer shall take application responsibility in all cases.

NEVER USE THE PRODUCT FOR AN APPLICATION INVOLVING SERIOUS RISK TO LIFE OR PROPERTY OR IN LARGE QUANTITIES WITHOUT ENSURING THAT THE SYSTEM AS A WHOLE HAS BEEN DESIGNED TO ADDRESS THE RISKS, AND THAT THE OMRON PRODUCT(S) IS PROPERLY RATED AND INSTALLED FOR THE INTENDED USE WITHIN THE OVERALL EQUIPMENT OR SYSTEM.

Programmable Products

Omron Companies shall not be responsible for the user's programming of a programmable Product, or any consequence thereof.

Disclaimers

Performance Data

Data presented in Omron Company websites, catalogs and other materials is provided as a guide for the user in determining suitability and does not constitute a warranty. It may represent the result of Omron's test conditions, and the user must correlate it to actual application requirements. Actual performance is subject to the Omron's Warranty and Limitations of Liability.

Change in Specifications

Product specifications and accessories may be changed at any time based on improvements and other reasons. It is our practice to change part numbers when published ratings or features are changed, or when significant construction changes are made. However, some specifications of the Product may

be changed without any notice. When in doubt, special part numbers may be assigned to fix or establish key specifications for your application. Please consult with your Omron's representative at any time to confirm actual specifications of purchased Product.

Errors and Omissions

Information presented by Omron Companies has been checked and is believed to be accurate; however, no responsibility is assumed for clerical, typographical or proofreading errors or omissions.

Statement of security responsibilities for assumed use cases and against threats

OMRON SHALL NOT BE RESPONSIBLE AND/OR LIABLE FOR ANY LOSS, DAMAGE, OR EXPENSES DIRECTLY OR INDIRECTLY RESULTING FROM THE INFECTION OF OMRON PRODUCTS, ANY SOFTWARE INSTALLED THEREON OR ANY COMPUTER EQUIPMENT, COMPUTER PROGRAMS, NETWORKS, DATABASES OR OTHER PROPRIETARY MATERIAL CONNECTED THERETO BY DISTRIBUTED DENIAL OF SERVICE ATTACK, COMPUTER VIRUSES, OTHER TECHNOLOGICALLY HARMFUL MATERIAL AND/OR UNAUTHORIZED ACCESS.

It shall be the users sole responsibility to determine and use adequate measures and checkpoints to satisfy the users particular requirements for (i) antivirus protection, (ii) data input and output, (iii) maintaining a means for reconstruction of lost data, (iv) preventing Omron Products and/or software installed thereon from being infected with computer viruses and (v) protecting Omron Products from unauthorized access.

Manual Structure

Page Structure

The following page structure is used in this manual.

The diagram illustrates the structure of a manual page, showing various elements and their corresponding annotations:

- Level 1 heading:** 4 Installation and Wiring
- Level 2 heading:** 4-3 Mounting Units
- Level 3 heading:** 4-3-1 Connecting Controller Components
- Text:** The Units that make up an NJ-series Controller can be connected simply by pressing the Units together and locking the sliders by moving them toward the back of the Units. The End Cover is connected in the same way to the Unit on the far right side of the Controller.
- A step in a procedure:** 1 Join the Units so that the connectors fit exactly.
- Diagram:** Illustration of units with labels: Hook, Connector, Hook holes.
- Text:** 2 The yellow sliders at the top and bottom of each Unit lock the Units together. Move the sliders toward the back of the Units as shown below until they click into place.
- Diagram:** Illustration of units with sliders, with labels: Move the sliders toward the back until they lock into place., Release, Lock, Slider.
- Section Header:** **Precautions for Correct Use**
- Text:** The sliders on the tops and bottoms of the Power Supply Unit, CPU Unit, I/O Units, Special I/O Units, and CPU Bus Units must be completely locked (until they click into place) after connecting the adjacent Unit connectors.
- Page tab:** 4
- Manual name:** NJ-series CPU Unit Hardware User's Manual (W500)
- Page number:** 4-9

Annotations on the right side of the diagram:

- Level 1 heading:** Points to the top grey bar.
- Level 2 heading:** Points to the sub-heading bar.
- Level 3 heading:** Points to the section heading bar.
- Gives the current headings:** Points to the text area.
- Page tab:** Points to the number '4' in a dark box.
- Gives the number of the main section:** Points to the number '4' in a dark box.

Annotations on the left side of the diagram:

- Level 2 heading:** Points to the sub-heading bar.
- Level 3 heading:** Points to the section heading bar.
- A step in a procedure:** Points to the numbered step.
- Indicates a procedure:** Points to the numbered step.
- Special information:** Points to the 'Precautions for Correct Use' section.
- Icons indicate precautions, additional information, or reference information:** Points to the icons below the precautions section.
- Manual name:** Points to the footer text.

This illustration is provided only as a sample. It may not literally appear in this manual.

Special Information

Special information in this manual is classified as follows:



Precautions for Safe Use

Precautions on what to do and what not to do to ensure safe usage of the product.



Precautions for Correct Use

Precautions on what to do and what not to do to ensure proper operation and performance.



Additional Information

Additional information to read as required.

This information is provided to increase understanding or make operation easier.



Version Information

Information on differences in specifications and functionality for Controller with different unit versions and for different versions of the Sysmac Studio is given.

Precaution on Terminology

In this manual, "download" refers to transferring data from the Sysmac Studio to the physical Controller and "upload" refers to transferring data from the physical Controller to the Sysmac Studio. For the Sysmac Studio, "synchronization" is used to both "upload" and "download" data. Here, "synchronize" means to automatically compare the data for the Sysmac Studio on the computer with the data in the physical Controller and transfer the data in the direction that is specified by the user.

Sections in this Manual

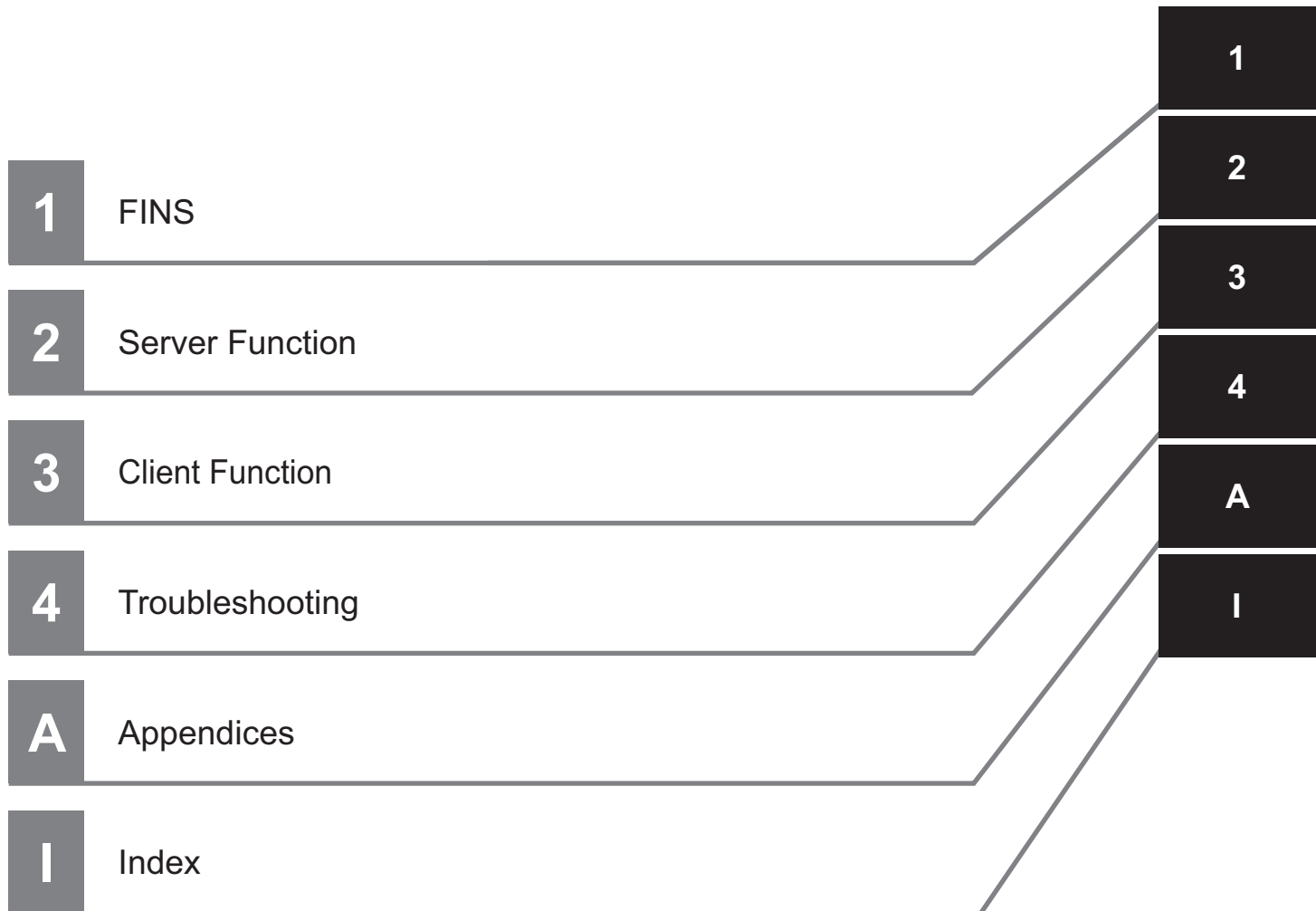

CONTENTS

Introduction	1
Intended Audience	1
Applicable Products	1
Relevant Manuals.....	2
Terms and Conditions Agreement.....	4
Warranty, Limitations of Liability	4
Application Considerations	5
Disclaimers	5
Statement of security responsibilities for assumed use cases and against threats.....	6
Manual Structure.....	7
Page Structure	7
Special Information	8
Precaution on Terminology	8
Sections in this Manual	9
Safety Precautions.....	12
Precautions for Safe Use	13
Precautions for Correct Use	14
Regulations and Standards	15
Versions	16
Unit Versions of CPU Units and Sysmac Studio Versions	16
Related Manuals.....	17
Revision History.....	19

Section 1 FINS

1-1 Overview of FINS	1-2
1-1-1 Server Function of FINS.....	1-2
1-1-2 Client Function of FINS	1-2
1-2 Applicable CPU Units	1-3
1-3 System Configuration.....	1-4
1-4 Relationship Between FINS Types and Units.....	1-5
1-5 Memory Used for CJ-series Units	1-6
1-5-1 Setting for the Memory Used for CJ-series Units	1-6
1-5-2 Compatible Memory for CJ-series Units	1-6

Section 2 Server Function

2-1 Overview of Server Function	2-2
--	------------

2-2	FINS Commands Supported by NX-series CPU Units.....	2-3
2-3	Setting of FINS Node Address of Built-in EtherNet/IP Port	2-5
2-4	FINS Routing Table Setting.....	2-7
2-5	FINS Write Protection Function.....	2-8
2-6	FINS Command Execution Condition	2-9
2-7	TCP/UDP Port Close Function	2-10

Section 3 Client Function

	Overview of Client Function.....	3-2
	FINS Communications Instructions	3-3
	Common Variables.....	3-4
	Send	3-6
	Rcv.....	3-10
	SendCmd.....	3-16

Section 4 Troubleshooting

4-1	Troubleshooting.....	4-2
-----	----------------------	-----

Appendices

A-1	Difference Between CS/CJ-series and NX-series in FINS Routing	A-2
A-1-1	Communication When 0 Is Specified for the Destination Network Address.....	A-2
A-1-2	Operation of Routing Table during Clear All Memory Operation	A-4

Index

Safety Precautions

Refer to the following manuals for safety precautions.

- *NX-series CPU Unit Hardware User's Manual (Cat. No. W535)*
- *NX-series NX502 CPU Unit Hardware User's Manual (Cat. No. W629)*
- *NX-series NX102 CPU Unit Hardware User's Manual (Cat. No. W593)*

Precautions for Safe Use

Refer to the following manuals for precautions for safe use.

- *NX-series CPU Unit Hardware User's Manual (Cat. No. W535)*
- *NX-series NX502 CPU Unit Hardware User's Manual (Cat. No. W629)*
- *NX-series NX102 CPU Unit Hardware User's Manual (Cat. No. W593)*

Precautions for Correct Use

Refer to the following manuals for precautions for correct use.

- *NX-series CPU Unit Hardware User's Manual (Cat. No. W535)*
- *NX-series NX502 CPU Unit Hardware User's Manual (Cat. No. W629)*
- *NX-series NX102 CPU Unit Hardware User's Manual (Cat. No. W593)*

Regulations and Standards

Refer to the following manuals for regulations and standards.

- *NX-series CPU Unit Hardware User's Manual (Cat. No. W535)*
- *NX-series NX502 CPU Unit Hardware User's Manual (Cat. No. W629)*
- *NX-series NX102 CPU Unit Hardware User's Manual (Cat. No. W593)*

Versions

Hardware revisions and unit versions are used to manage the hardware and software in NX-series Units and EtherCAT slaves. The hardware revision or unit version is updated each time there is a change in hardware or software specifications. Even when two Units or EtherCAT slaves have the same model number, they will have functional or performance differences if they have different hardware revisions or unit versions.

Refer to the following manuals for versions.

- *NX-series CPU Unit Hardware User's Manual (Cat. No. W535)*
- *NX-series NX502 CPU Unit Hardware User's Manual (Cat. No. W629)*
- *NX-series NX102 CPU Unit Hardware User's Manual (Cat. No. W593)*
- *NX-series NX1P2 CPU Unit Hardware User's Manual (Cat. No. W578)*
- *NJ-series CPU Unit Hardware User's Manual (Cat No. W500)*

Unit Versions of CPU Units and Sysmac Studio Versions

The functions that are supported depend on the unit version of the NX-series CPU Unit. The version of Sysmac Studio that supports the functions that were added for an upgrade is also required to use those functions.

Refer to the *NJ/NX-series CPU Unit Software User's Manual (Cat. No. W501)* for the relationship between the unit versions of the CPU Units and the Sysmac Studio versions and for the functions that are supported by each unit version.

Related Manuals

The following manual are related. Use these manuals for reference.

Manual name	Cat. No.	Model	Application	Contents
NX-series CPU Unit Hardware User's Manual	W535	NX701-□□□□	Learning the basic specifications of the NX701 CPU Units, including introductory information, designing, installation, and maintenance. Mainly hardware information is provided.	An introduction to the entire NX701 system is provided along with the following information on the CPU Unit. <ul style="list-style-type: none"> • Features and system configuration • Introduction • Part names and functions • General specifications • Installation and wiring • Maintenance and inspection
NX-series NX502 CPU Unit Hardware User's Manual	W629	NX502-□□□□	Learning the basic specifications of the NX502 CPU Units, including introductory information, designing, installation, and maintenance. Mainly hardware information is provided.	An introduction to the entire NX502 system is provided along with the following information on the CPU Unit. <ul style="list-style-type: none"> • Features and system configuration • Introduction • Part names and functions • General specifications • Installation and wiring • Maintenance and inspection
NX-series NX102 CPU Unit Hardware User's Manual	W593	NX102-□□□□	Learning the basic specifications of the NX102 CPU Units, including introductory information, designing, installation, and maintenance. Mainly hardware information is provided.	An introduction to the entire NX102 system is provided along with the following information on the CPU Unit. <ul style="list-style-type: none"> • Features and system configuration • Introduction • Part names and functions • General specifications • Installation and wiring • Maintenance and inspection
NJ/NX-series CPU Unit Software User's Manual	W501	NX701-□□□□ NX502-□□□□ NX102-□□□□ NX1P2-□□□□ NJ501-□□□□ NJ301-□□□□ NJ101-□□□□	Learning how to program and set up an NJ/NX-series CPU Unit. Mainly software information is provided.	The following information is provided on a Controller built with an NJ/NX-series CPU Unit. <ul style="list-style-type: none"> • CPU Unit operation • CPU Unit features • Initial settings • Programming based on IEC 61131-3 language specifications
NX-series CPU Unit FINS Function User's Manual	W596	NX701-□□□20 NX502-□□□□ NX102-□□□□	Using the FINS function of an NX-series CPU Unit.	Describes the FINS function of an NX-series CPU Unit.
NJ/NX-series Troubleshooting Manual	W503	NX701-□□□□ NX502-□□□□ NX102-□□□□ NX1P2-□□□□ NJ501-□□□□ NJ301-□□□□ NJ101-□□□□	Learning about the errors that may be detected in an NJ/NX-series Controller.	Concepts on managing errors that may be detected in an NJ/NX-series Controller and information on individual errors are described.
Sysmac Studio Version 1 Operation Manual	W504	SYSMAC -SE2□□□	Learning about the operating procedures and functions of the Sysmac Studio.	Describes the operating procedures of the Sysmac Studio.
CS/CJ-series Ethernet unit Application Construction User's Manual	W421	CS1W-ETN21 CJ1W-ETN21	Using an Ethernet unit	This manual describes the mail send function, mail receive function, socket service function, clock information automatic adjustment function, FTP server function, and host application creation of FINS communications.

Manual name	Cat. No.	Model	Application	Contents
CS/CJ/CP/NSJ-series Communications Commands Reference Manual	W342	CS1G/H-CPU□□ CS1D-CPU□□□ CS1W-SC□□□-V1 CJ1G/H-CPU□□□ CJ1M-CPU□□ CJ2H-CPU6□ CJ2M-CPU□□ CJ1W-SCU□□-V1 CP1H-□□□□ CP1L-M/L□□□ CP1E-□□□D□	Learning the detailed communication com- mands for the CS/CJ/CP-series CPU Unit and NSJ- series.	This manual describes the C mode commands and FINS commands for the CPU unit in detail.

Revision History

A manual revision code appears as a suffix to the catalog number on the front and back covers of the manual.



Revision code	Revision date	Revised content
01	April 2018	Original production
02	June 2022	Corrected mistakes.
03	January 2023	Corrected mistakes.
04	April 2023	Made changes accompanying the addition of NX502-1□□□ CPU Units.
05	July 2024	Corrected mistakes.

1

FINS

This section describes an overview, a system configuration, and types of FINS.

1-1	Overview of FINS	1-2
1-1-1	Server Function of FINS	1-2
1-1-2	Client Function of FINS	1-2
1-2	Applicable CPU Units	1-3
1-3	System Configuration	1-4
1-4	Relationship Between FINS Types and Units	1-5
1-5	Memory Used for CJ-series Units	1-6
1-5-1	Setting for the Memory Used for CJ-series Units	1-6
1-5-2	Compatible Memory for CJ-series Units.....	1-6

1-1 Overview of FINS

FINS is a command system for the message service that can be used commonly in OMRON network. The FINS command system allows to read sent and received data, status etc. between a host computer and an NX-series CPU Unit, and between an NX-series CPU Unit and an OMRON CPU Unit. FINS provides server and client functions.

For details about the FINS frame format, refer to the *SYSMAC CS/CJ/CP/NSJ-series Communications Commands Reference Manual (Cat. No. W342)*.



Precautions for Correct Use

We do not recommend to use the FINS function because it may be unsupported in future OMRON products. Use other communications functions when you design new communications.

1-1-1 Server Function of FINS

This function allows to receive FINS commands from external devices such as host computers or OMRON CPU Units and then to execute requested services.

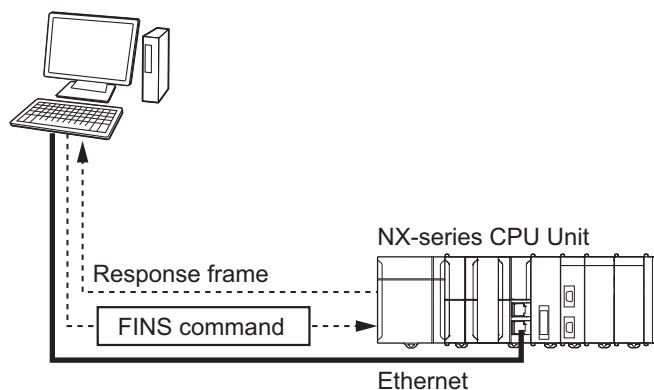

1-1-2 Client Function of FINS

This function allows NX502 and NX102 CPU Units to send and receive data to/from OMRON Units which is provided with the FINS server function.

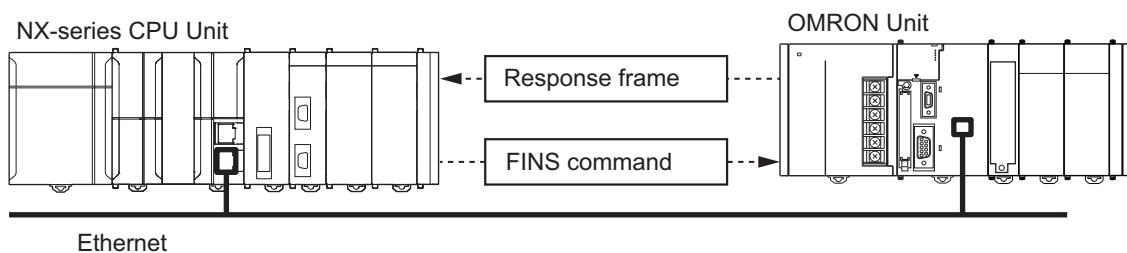

1-2 Applicable CPU Units

FINS commands can be sent/received from/by the following CPU Units.

Unit name	Model	Server function	Client function	Unit version of CPU Unit
NX7 Database Connection CPU Unit	NX701-□□20 *1*2	Available	Not available	Version 1.16 or later
NX502 CPU Unit	NX502-1□□□ *2	Available	Available	Version 1.60 or later
NX102 CPU Unit	NX102-□□□□ *2	Available	Available	

*1. NX701-□□00 does not support the FINS server function and FINS client function.

*2. Only port 2 of the built-in EtherNet/IP ports supports FINS commands. Port 1 does not support.

1-3 System Configuration

System configuration is available on conditions that it must issue FINS commands received from external computers and OMRON CPU Units and receive FINS commands through the built-in EtherNet/IP port of the NX-series CPU Unit.

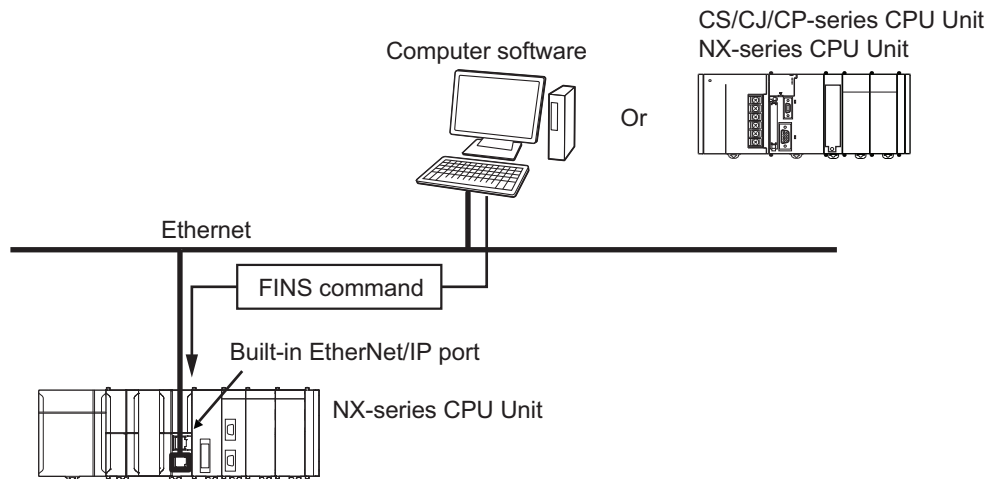

1-4 Relationship Between FINS Types and Units

The following shows the relationship between applicable FINS types and Units.

Item		Units		
		NX701-□□20	NX502-1□□□	NX102-□□□□
FINS/UDP	Usable or not	Yes		
	Port number	9600 *1		
FINS/TCP	Usable or not	Yes		
	Maximum number of connections	16 *2		
	Port number	9600 *1		
FINS communication service on Ethernet	Number of nodes	254		
	Message length	Max. 2,012 bytes		

*1. This can be changed.

*2. This is total number of server and client connections.

1-5 Memory Used for CJ-series Units

The following describes how to set the memory used for the CJ-series Units and the area types of the compatible memory used for CJ-series Units.

1-5-1 Setting for the Memory Used for CJ-series Units

For NX701-□□20, NX502-1□□□, and NX102 CPU Units, the memory used for CJ-series Units can be set using the Multiview Explorer of the Sysmac Studio.

Select **Configuration and Setup - Controller Setup**, and then use **Memory Settings** to set the area type and each address range of the memory used for the CJ-series Units.

For details, refer to the *Sysmac Studio Version 1 Operation Manual (Cat. No. W504)*.

1-5-2 Compatible Memory for CJ-series Units

NX701-□□20, NX502-1□□□, and NX102 CPU Units are compatible with the following area types of the memory used for CJ-series Units.

- CIO Area
- Work Area
- Holding Area
- Data Memory Area
- Expansion Memory Area

For details about the specifications of memory for the CJ Units, refer to the *NJ/NX-series CPU Unit Software User's Manual (Cat. No. W501)*.

2

Server Function

This section describes a function that issues FINS commands supported by the NX-series CPU Unit and, reads and writes the memory used for CJ-series Units.

2-1	Overview of Server Function	2-2
2-2	FINS Commands Supported by NX-series CPU Units	2-3
2-3	Setting of FINS Node Address of Built-in EtherNet/IP Port.....	2-5
2-4	FINS Routing Table Setting	2-7
2-5	FINS Write Protection Function	2-8
2-6	FINS Command Execution Condition.....	2-9
2-7	TCP/UDP Port Close Function	2-10

2-1 Overview of Server Function

The NX-series CPU Unit receives FINS commands issued from external devices such as host computers or CS/CJ/CP-series CPU Units on the Ethernet network and then can execute the requested service.



Precautions for Correct Use

To use the FINS server function, select **Configurations and Setup - Controller Setup - Built-in EtherNet/IP Port Settings** from the Multiview Explorer of the Sysmac Studio, and then select **FINS Settings** to select the **Use** Option for **FINS/UDP** and **FINS/TCP**. If the **Do no use** Option is selected, response to FINS command is not returned because the FINS server function does not work.

If Packet Filter is used in the NX-series CPU Unit, you must configure Packet Filter to allow the reception of FINS commands. If the reception is not allowed by Packet Filter, the Controller cannot receive the FINS command and a timeout error will occur on the client side. The following Controllers must be configured for reception of FINS/UDP and FINS/TCP commands.

- FINS/UDP

Controllers that receive FINS commands

- FINS/TCP

Controllers for which **Server** is selected in the **FINS/TCP Connection Settings**, which are configured by selecting **Controller Setup - Built-in EtherNet/IP Port Settings - FINS Settings - FINS/TCP**.

2-2 FINS Commands Supported by NX-series CPU Units

This section describes FINS commands supported by the NX-series CPU Unit, restrictions, and execution conditions.

For details about each FINS command, refer to the *SYSMAC CS/CJ/CP/NSJ-series Communications Commands Reference Manual (Cat. No. W342)*.

FINS Commands Supported by NX-series CPU Units and Restrictions

The following describes FINS commands supported by the NX-series CPU Units and restrictions when they are used.

Command code (Hex)		Command name	Restrictions
MR	SR		
01	01	MEMORY AREA READ	Only areas that exist in the memory of CJ-series Units are accessible.
01	02	MEMORY AREA WRITE	
01	03	MEMORY AREA FILL	
01	04	MULTIPLE MEMORY AREA READ	
01	05	MEMORY AREA TRANSFER	
05	01	CPU UNIT DATA READ	Only the following values can be read. *1 <ul style="list-style-type: none"> • CPU Unit model • CPU Unit version
06	01	CPU UNIT STATUS READ	Only the following values can be read. *2 *3 *4 <ul style="list-style-type: none"> • Operation status • Operating mode
07	01	CLOCK READ	None
07	02	CLOCK WRITE	

*1. Fixed values are returned for the following values.

- DIP switch information: Fixed at 0
- Program area size: Fixed at 14 hex.
- Timer/counter size: Fixed at 08 hex.
- Memory card type: SD Memory Card fixed at 04 hex. (regardless of the presence status)
- SD memory card size: SD Memory Card fixed at FFFF hex. when a memory card is inserted. Fixed at 00 hex. when a memory card is not inserted
- Remote I/O information: Fixed at 0

*2. Two pieces of information shown below are processed as error information of the NX-series.

- Fatal error information: A value of 0000 hex. is returned when the major fault level is normal. A value of 0001 hex. is returned when the major fault level is abnormal.
- Non-fatal error information: A value of 0000 hex. is returned when the partial fault level or minor fault level is normal. A value of 0001 hex. is returned when the partial fault level or minor fault level is abnormal.

*3. All below values are returned fixed at 0.

"CPU status", "Battery presence", "Built-in flash memory access status", "Message presence", "Failure code"

- *4. Sixteen ASCII code 20Hex (space) characters of below value are returned and can not be used.
"Error message"

2-3 Setting of FINS Node Address of Built-in EtherNet/IP Port

This FINS node address is necessary to identify a node in the FINS communication.

The following describes how to determine the FINS node address of the built-in EtherNet/IP port and how to set the FINS node address from the Sysmac Studio.

IP address - FINS address conversion method *1	FINS node address determination method	Setting method from Sysmac Studio
Automatic generation method	The least significant digits of the IP address becomes the FINS node address automatically.	Controller Setup - Built-in EtherNet/IP Port Settings - TCP/IP Settings - IP Address Settings
Combined method IP address table method	Set the FINS node address itself.	Controller Setup - Built-in EtherNet/IP Port Settings - FINS Settings - FINS Node Address Settings

*1. This may vary depending on the setting of **IP address - FINS address conversion method** for FINS/UDP. To make the setting, select **Configurations and Setup - Controller Setup - Built-in EtherNet/IP Port Settings - FINS Settings - FINS/UDP - IP Address - FINS Address Conversion Method** from the Multi-view Explorer of the Sysmac Studio.

When the automatic generation method is selected, the least significant digit of the IP address is set as the FINS node address.

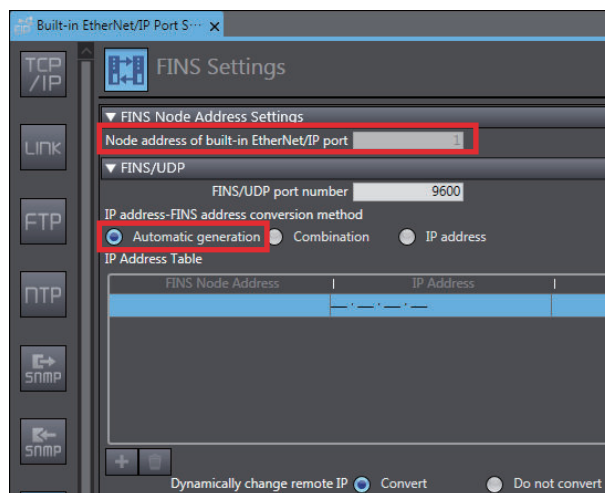

When the combination or IP address method is selected, the value specified for the FINS node address settings is used as the FINS node address.

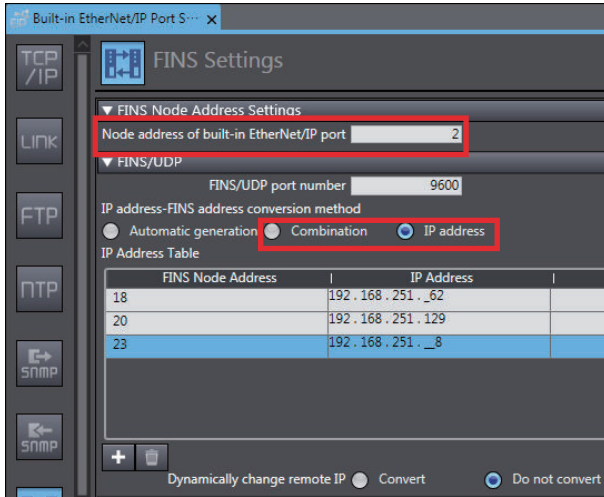

2-4 FINS Routing Table Setting

The routing table is a table that is used to find the communication path of the FINS message when the FINS communication service is in use.

The routing table consists of two types of tables: local network table and relay network table.

Here are the cases, where the setting of FINS routing table is required.

- When the FINS routing table is already set at one or more nodes in the same network and the FINS message communications are performed, the local network table setting is required.
For details, refer to *A-1 Difference Between CS/CJ-series and NX-series in FINS Routing* on page A-2.
- When the FINS command is issued over the level of the FINS network, the relay network table setting is required.

To set the FINS routing table, select **Configurations and Setup - Controller Setup - Operation Settings - FINS Settings** from the Multiview Explorer of the Sysmac Studio.

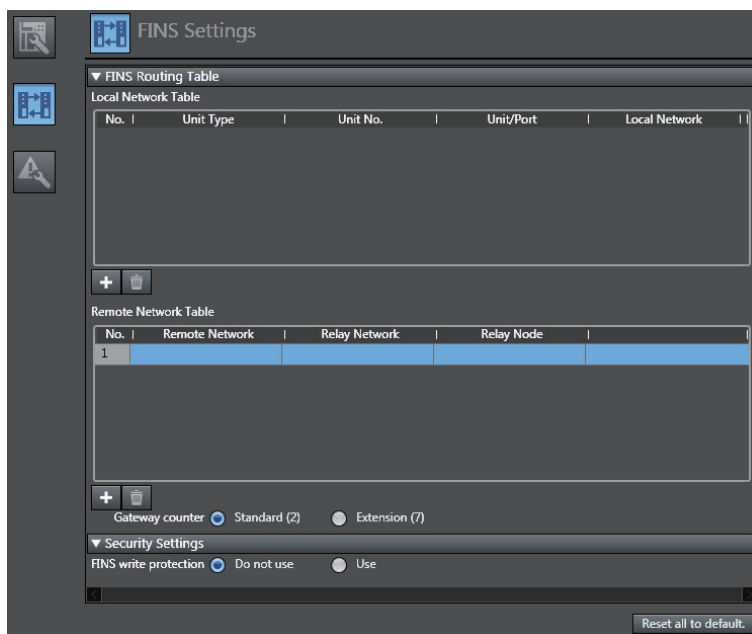

2-5 FINS Write Protection Function

When data is written into the CPU Unit using the FINS command, this data writing can be disabled so that the data is not written into the memory of the CPU Unit.

This function is called the FINS write protection function.

The models that support the FINS write protection function are NX701-□□20, 502-1□□□, and NX102-□□□□.

To set whether to use the write protection function, select **Configurations and Setup - Controller Setup - Operation Settings - FINS Settings - Security Settings** from the Multiview Explorer of the Sysmac Studio.

Even when the FINS write protection function is enabled, the data reading from the CPU Unit is still possible.

For details, refer to the *Sysmac Studio Version 1 Operation Manual (Cat. No. W504)*.

2-6 FINS Command Execution Condition

The following describes the FINS command execution conditions.

Command code (Hex)		Command name	Execution condition		
MR	SR		RUN mode	PROGRAM mode	Write protection in process
01	01	MEMORY AREA READ	Supported	Supported	Supported
01	02	MEMORY AREA WRITE			Not supported
01	03	MEMORY AREA FILL			Not supported
01	04	MULTIPLE MEMORY AREA READ			Supported
01	05	MEMORY AREA TRANSFER			Not supported
05	01	CPU UNIT DATA READ			Supported
06	01	CPU UNIT STATUS READ			Supported
07	01	CLOCK READ			Supported
07	02	CLOCK WRITE			Not supported

2-7 TCP/UDP Port Close Function

You can close unused FINS/UDP and FINS/TCP ports. This improves security of communications over the network.

The procedure for closing FINS/UDP port and FINS/TCP port, operation, and timing of the setting to be applied are as follows.

Port	Procedure for closing the port	When to apply the setting
FINS/UDP port	Select Configurations and Setup - Controller Setup - Built-in EtherNet/IP Port Settings from the Multiview Explorer of the Sysmac Studio, and then select FINS Settings - FINS/UDP to select the Do not use Option.	When the setting is transferred.
FINS/TCP port	Select Configurations and Setup - Controller Setup - Built-in EtherNet/IP Port Settings from the Multiview Explorer of the Sysmac Studio, and then select FINS Settings - FINS/TCP to select the Do not use Option.	When the setting is transferred.

For the details on the settings, refer to *Sysmac Studio Version 1 Operation Manual (Cat. No. W504)*.



Precautions for Correct Use

- If the **Do not use** option is selected for both of the FINS/UDP and FINS/TCP, the following restriction will arise.
Any of the Send instruction, Rcv instruction, and SendCmd instruction will result in an error.
- If the **Do not use** option is selected for the FINS/UDP, the following restriction will arise.
The NB-series Programmable Terminals cannot be connected.



Version Information

FINS/TCP and FINS/UDP port close function is available in the following CPU Units of the stated unit versions.

- NX102-□□□□: Version 1.49 or later
- NX701-□□20: Version 1.29 or later

3

Client Function

This section describes the instructions that issue the FINS command from the NX102 CPU Unit for OMRON Unit provided with the FINS server function and then send and receive data.

Overview of Client Function	3-2
FINS Communications Instructions.....	3-3

Overview of Client Function

FINS communication instructions is a set of instructions, which allows to control data send/receive, mode change etc. as required, for various types of Units such as CPU Units and CPU Special Units on the network or CPU Rack.

These instructions are executed over multiple cycles and perform the communication non-synchronized with the cycle.

FINS Communications Instructions

Instructions	Name	Page
Send	Send to Network	page 3-6
Rcv	Receive from Network	page 3-10
SendCmd	Send Command	page 3-16

Common Variables

The specifications of variables that are used for many instructions (Execute, Done, Busy, Error, ErrorID, and ErrorIDEx) are described below.

These variables are not described in the tables of variables for individual instructions. Check the graphic or ST expression for the instruction to see if the instruction uses these variables.

Execute, Done, and Busy

Execute is an input variable that gives the execution condition for some FB instructions. Instruction execution starts when *Execute* changes to TRUE. After *Execute* changes to TRUE, execution of this instruction is continued until the processing is completed even if the value changes to FALSE or the instruction execution time exceeds the task period.

Done is an output variable that shows the completion of execution for some FB instructions.

Busy is an output variable that shows that instruction execution is in progress for some FB instructions.

	Name	Input/output	Contents	Data type	Valid range	Initial value
Execute	Execute	Input	TRUE: Instruction is executed. *1 FALSE: Instruction is not executed.*2	BOOL	TRUE or FALSE	FALSE
Done	Done	Output	TRUE: Normal end *3 *4 FALSE: Error end, execution in progress, or execution condition not met.	BOOL	TRUE or FALSE	---
Busy	Busy		TRUE: Execution processing is in progress. FALSE: Execution processing is not in progress.			

*1. If the value of *Execute* is already TRUE when Controller operation starts, the instruction is not executed. To execute the instruction, change the value of *Execute* to FALSE.

*2. Processing is continued to the end even if the value changes to FALSE during execution.

*3. The value of *Done* changes to FALSE when the execution condition is no longer met after a normal end.

*4. If the execution condition is no longer met when a normal end occurs, the value of *Done* is TRUE for one task period, and it then changes to FALSE.

Error, ErrorID, and ErrorIDEx

Error, *ErrorID*, and *ErrorIDEx* are output variables used by some FB instructions, and indicate error end of the instructions.

	Name	Input/output	Contents	Data type	Valid range	Initial value
Error	Error	Output	TRUE: Error end *1 *2 FALSE: Normal end, execution in progress, or execution condition not met.	BOOL	TRUE or FALSE	---
ErrorID	Error code		This is the error ID for an error end. The value is WORD#16#0 for a normal end.	WORD	Depends on the instruction.	
ErrorIDEx	Expansion error code		This is the error ID for an Expansion Unit Hardware Error. The value is DWORD#16#0 for a normal end.	DWORD		

*1. The value of *Error* changes to FALSE when the execution condition is no longer met after the error end.

*2. If the execution condition is no longer met when an error end occurs, the value of *Error* is TRUE for one task period and it then changes to FALSE.

Send

Sends data to a node on the network.

Instruction	Name	FB/ FUN	Graphic expression	ST expression
Send	Send to Network	FB		Send_instance(Execute, DstNetAdr, CommPort, SrcDat, SendSize, DstArea, DstCh, Option, Done, Busy, Error, ErrorID, ErrorIDEx);

Variable

	Name	Input/ output	Contents	Valid range	Unit	Initial value
DstNetAdr	Network address at send destination	Input	Specifies the network address and node address at send destination	---	---	---
CommPort	Designation of port at send destination		Specifies the serial port at send destination	_NONE	---	_NONE
SrcDat[] array	First element of array at send destination		Beginning of data (array) to be sent	16#0000 to 16#FFFF	---	*1
SendSize	Number of send words		Specifies the number of words in the send data	0 to Max. data length *2	Word	1
DstArea	Area at send destination		Specifies the area type at send destination	_CIO _WR _HR _TIMER _COUNTER _DM _EM0 : _EM18	---	_DM
DstCh	CH at send destination		Specifies the first ch at send destination	0 to 32,767	ch	0
Option	Response		Specifies response monitoring and resending	---	---	---

*1. If you omit an input parameter, the default value is not applied. A building error will occur.

*2. This may vary depending on the network type.

	Boo lean	Bit strings				Integers							Real num bers		Times, durations, dates, and text strings					
	BOOL	BYTE	WORD	DWORD	LWORD	USINT	UINT	UDINT	ULINT	SINT	INT	DINT	LINT	REAL	LREAL	TIME	DATE	TOD	DT	STRING
DstNetAdr	Refer to <i>Function</i> on page 3-7 for details on the structure <code>_sDNET_ADR</code> .																			
CommPort	For enumeration <code>_ePORT</code> enumerator, refer to <i>Function</i> on page 3-7.																			
SrcDat[] ar- ray			OK																	
SendSize							OK													
DstArea	For enumeration <code>_eAREA</code> enumerator, refer to <i>Function</i> on page 3-7.																			
DstCh							OK													
Option	Refer to <i>Function</i> on page 3-7 for details on the structure <code>_sRESPONSE</code> .																			

Function

When *Execute* changes from FALSE to TRUE, *SrcDat[]* is written to the area at the send destination specified by *DstNetAdr*, *CommPort*, *DstArea*, and *DstCh*.

The data type of *DstNetAdr* is structure `_sDNET_ADR`. The specifications are shown below.

Variable	Name	Contents	Data type	Valid range	Unit	Initial value
DstNetAdr	Network address at send destination	Network address at send destination	<code>_sDNET_ADR</code>	---	---	---
NetNo	Network address	Network address	USINT	0 to 127	---	0
NodeNo	Node address	Node address	USINT	Depends on the data type		
UnitNo	Unit address	Unit address	BYTE	Depends on the data type		

The data type of *CommPort* is enumeration `_ePORT`.

The meaning of the enumerator of enumeration `_ePORT` is as follows.

Enumerator	Meaning
<code>_NONE</code>	The send destination is not a serial port (host link mode).

The data type of *DstArea* is enumeration `_eAREA`.

The meaning of the enumerator of enumeration `_eAREA` is as follows.

Enumerator	Meaning
<code>_CIO</code>	Core I/O Area, Work Area, etc.
<code>_WR</code>	Work Area
<code>_HR</code>	Holding Area
<code>_TIMER</code>	Timer Area
<code>_COUNTER</code>	Counter Area
<code>_DM</code>	Data Memory Area
<code>_EM0</code>	0 bank area of Expansion Memory Area
:	:

Enumerator	Meaning
_EM18	24 bank area of Expansion Memory Area

The data type of *Option* is structure *_sRESPONSE*. The specifications are shown below.

Variable	Name	Contents	Data type	Valid range	Unit	Initial value
Option	Response	Response monitoring and retry specifications	_sRESPONSE	---	---	---
	isNonResp	TRUE: Response is not required. FALSE: Response is required.	BOOL	Depends on the data type	---	FALSE
	TimeOut	Timeout time 0: 2.0 s	UINT		0.1 s	20 (2.0 s)
	Retry	Retry count	USINT	0 to 15	Count	0

If no response is returned within the timeout time *Option.TimeOut* when the value of the Response Not Necessary Flag *Option.isNonResp* is FALSE, the command is retried until the response is returned.

The retry count is specified by *Option.Retry*.

The timeout time is *Option.TimeOut* x 0.1 s. However, when the value of *Option.TimeOut* is 0, the timeout time becomes 2.0 s. The initial value of *Option.TimeOut* is also 2.0 s.

Related System-defined Variables

Name	Meaning	Data type	Description
_Port_numUsingPort	Number of Used Ports	USINT	This is the number of ports that are currently used.
_Port_isAvailable	Network Communications Instruction Enabled Flag	BOOL	TRUE: A port is available. FALSE: A port is not available.

Precautions for Correct Use

- This instruction can be executed only when there is an available port. Therefore, use the system-defined variable *_Port_isAvailable* (Network Communications Instruction Enabled Flag) in an N.O. execution condition for the instruction.
- The command is not sent if the value of *SendSize* is 0. In that case, the value of *Done* changes to TRUE.
- During execution of this instruction, set *Option.Retry* to a value other than 0 by considering the case when the send message or response is lost due to noise that occurs during communication. If no response is returned within *Option.TimeOut*, try to resend the message.
- Refer to the *CS/CJ/CP/NSJ-series Communications Commands Reference Manual (Cat. No. W342)* for specification of network address.

The FINS routing specification in the NX-series CPU Units differ from those in the CS/CJ-series CPU Units.

Refer to *A-1 Difference Between CS/CJ-series and NX-series in FINS Routing* on page A-2 for information on differences in routing specification.

- When this instruction is written in the ST program, make sure that the instruction is executed for each task period during execution of this instruction. Otherwise, normal processing may not be possible.
- You cannot use this instruction in an event task. A compiling error will occur.
- The maximum number of Send, Rcv, and SenCmd instructions that can be executed simultaneously is 32.
- An error will occur in the following cases. *Error* will change to TRUE.
 - a) A member of *DstNetAdr* is outside of its range.
 - b) *SendSize*, *DstArea*, or *DstCh* is outside of its range.
 - c) A member of *Option* is outside of its range.
 - d) The value of *SendSize* exceeds the size of *SrcDat[]*.
 - e) The value of *_Port_isAvailable* is FALSE.
 - f) Communications fail.
 - g) The **Do not use** option is selected for FINS/UDP and FINS/TCP connection has not been established.
 - h) More than 32 Send, Rcv, and SendCmd instructions are executed simultaneously.
- If the value of Error code "Error ID" is WORD#16#0800, the expansion error code "ErrorIDEx" has the meaning of end code for the communication command in this instruction.
Refer to *End Codes in 5-1 Command Lists* of the *SYSMAC CS/CJ/CP/NSJ-series Communications Commands Reference Manual (Cat. No. W342)* for details.

Sample Programming

Refer to *Sample Programming* on page 3-13 of the Rcv instruction.

Rcv

Requests a node on the network to send and receives data.

Instruction	Name	FB/ FUN	Graphic expression	ST expression
Rcv	Receive from Network	FB		Rcv_instance(Execute, SrcNetAdr, CommPort, SrcArea, SrcCh, RcvSize, DstDat, Option, Done, Busy, Error, ErrorID, ErrorIDEx);

Variable

	Name	Input/ output	Contents	Valid range	Unit	Initial value	
SrcNetAdr	Network address at source	Input	Specifies the network address and node address at send source	---	---	---	
CommPort	Designation of port at receive destination		Selects the serial port at receive destination	_NONE	---	_NONE	
SrcArea	Data source area		Specifies the area type at send source	_CIO _WR _HR _TIMER _COUNTER _DM _EM0 : _EM18	---	---	_DM
SrcCh	Data source CH		Specifies the first ch at send source	0 to 32,767	ch	0	
RcvSize	Number of receive words		Specifies the number of words in the receive data.	0 to Max. data length *1	Word	1	
Option	Response		Specifies response monitoring and resending	---	---	---	
DstDat[] array	First element of receive array	Input/output	Beginning of data (array) to be received	16#0000 to 16#FFFF	---	*2	

*1. This may vary depending on the network type.

*2. If you omit an input parameter, the default value is not applied. A building error will occur.

	Boo lean	Bit strings				Integers							Real num- bers		Times, durations, dates and text strings					
	BOOL	BYTE	WORD	DWORD	LWORD	USINT	UINT	UDINT	ULINT	SINT	INT	DINT	LINT	REAL	LREAL	TIME	DATE	TOD	DT	STRING
SrcNetAdr	Refer to <i>Function</i> on page 3-11 for details on the structure <code>_sDNET_ADR</code> .																			
CommPort	For enumeration <code>_ePORT</code> enumerator, refer to <i>Function</i> on page 3-11.																			
SrcArea	For enumeration <code>_eAREA</code> enumerator, refer to <i>Function</i> on page 3-11.																			
SrcCh							OK													
RcvSize							OK													
Option	Refer to <i>Function</i> on page 3-11 for details on the structure <code>_sRESPONSE</code> .																			
DstDat[] ar- ray			OK																	

Function

When *Execute* changes from FALSE to TRUE, *SrcNetAdr* and *CommPort* are requested to send the data specified by *SrcArea* and *SrcCh*.

The received data is stored in *DstDat[]*.

The data type of *SrcNetAdr* is `structure_sDNET_ADR`. The specifications are shown below.

Variable	Name	Contents	Data type	Valid range	Unit	Initial value
SrcNetAdr	Network address at source	Specifies the network address and node address at send source	<code>_sDNET_ADR</code>	---	---	---
NetNo	Network address	Network address	USINT	0 to 127	---	0
NodeNo	Node address	Node address	USINT	Depends on data type.		
UnitNo	Unit address	Unit address	BYTE	Depends on data type.		

The data type of *CommPort* is `enumeration_ePORT`.

The meaning of the enumerator of `enumeration_ePORT` is as follows.

Enumerator	Meaning
<code>_NONE</code>	The send destination is not a serial port (host link mode).

The data type of *SrcArea* is `enumeration_eAREA`.

The meaning of the enumerator of `enumeration_eAREA` is as follows.

Enumerator	Meaning
<code>_CIO</code>	Core I/O Area, Work Area, etc.
<code>_WR</code>	Work Area
<code>_HR</code>	Holding Area
<code>_TIMER</code>	Timer Area
<code>_COUNTER</code>	Counter Area
<code>_DM</code>	Data Memory Area
<code>_EM0</code>	0 bank area of Expansion Memory Area

Enumerator	Meaning
:	:
_EM18	24 bank area of Expansion Memory Area

The data type of *Option* is structure *_sRESPONSE*. The specifications are shown below.

Variable	Name	Contents	Data type	Valid range	Unit	Initial value
Option	Response	Response monitoring and retry specifications	_sRESPONSE	---	---	---
	isNonResp	TRUE: Response is not required. FALSE: Response is required.	BOOL	Depends on data type.	---	FALSE
	TimeOut	Timeout time 0: 2.0 s	UINT		0.1 s	20 (2.0 s)
	Retry	Retry count	USINT	0 to 15	Count	0

If no response is returned within the timeout time *Option.TimeOut* when the value of the Response Not Necessary Flag *Option.isNonResp* is FALSE, the command is retried until the response is returned. The retry count is specified by *Option.Retry*.

The timeout time is *Option.TimeOut* x 0.1 s. However, when the value of *Option.TimeOut* is 0, the timeout time becomes 2.0 s. The initial value of *Option.TimeOut* is also 2.0 s.

Related System-defined Variables

Name	Meaning	Data type	Description
_Port_numUsingPort	Number of Used Ports	USINT	This is the number of ports that are currently used.
_Port_isAvailable	Network Communications Instruction Enabled Flag	BOOL	TRUE: A port is available. FALSE: A port is not available.

Precautions for Correct Use

- This instruction can be executed only when there is an available port. Therefore, use the system-defined variable *_Port_isAvailable* (Network Communications Instruction Enabled Flag) in an N.O. execution condition for the instruction.
- The command is not sent if the value of *RcvSize* is 0. In that case, the value of *Done* changes to TRUE.
- During execution of this instruction, set *Option.Retry* to a value other than 0 by considering the case when the send message or response is lost due to noise that occurs during communication. If no response is returned within *Option.TimeOut*, try to resend the message.
- Refer to the *CS/CJ/CP/NSJ-series Communications Commands Reference Manual (Cat. No. W342)* for specification of network address.

The FINS routing specification in the NX-series CPU Units differ from those in the CS/CJ-series CPU Units.

Refer to *A-1 Difference Between CS/CJ-series and NX-series in FINS Routing* on page A-2 for information on differences in routing specification.

- When this instruction is written in the ST program, make sure that the instruction is executed for each task period during execution of this instruction. Otherwise, normal processing may not be possible.
- You cannot use this instruction in an event task. A compiling error will occur.
- The maximum number of Send, Rcv, and SenCmd instructions that can be executed simultaneously is 32.
- An error will occur in the following cases. *Error* will change to TRUE.
 - a) A member of *SrcNetAdr* is outside of its range.
 - b) Broadcasting (*SrcNetAdr.NodeNo.=255*) is set.
 - c) Any of *SrcArea*, *SrcCh*, and *RcvSize* is outside of its range.
 - d) The value of *RcvSize* exceeds the size of *DstDat[]*.
 - e) The data type that is not supported is specified for *DstDat[]*.
 - f) A member of *Option* is outside of its range.
 - g) *Option.isNonResp* is TRUE and this instruction is executed.
 - h) The value of *_Port_isAvailable* is FALSE.
 - i) Communications fail.
 - j) The **Do not use** option is selected for FINS/UDP and FINS/TCP connection has not been established.
 - k) More than 32 Send, Rcv, and SendCmd instructions are executed simultaneously.
- If the value of Error code "Error ID" is WORD#16#0800, the expansion error code "ErrorIDEx" has the meaning of end code for the communication command in this instruction.

Refer to *End Codes in 5-1 Command Lists of the SYSMAC CS/CJ/CP/NSJ-series Communications Commands Reference Manual (Cat. No. W342)* for details.

Sample Programming

A 2CH data write command is sent to DM100 of network No. 0, node No. 2, and Unit No. 0. Then, the 2CH data read command is sent from DM100.

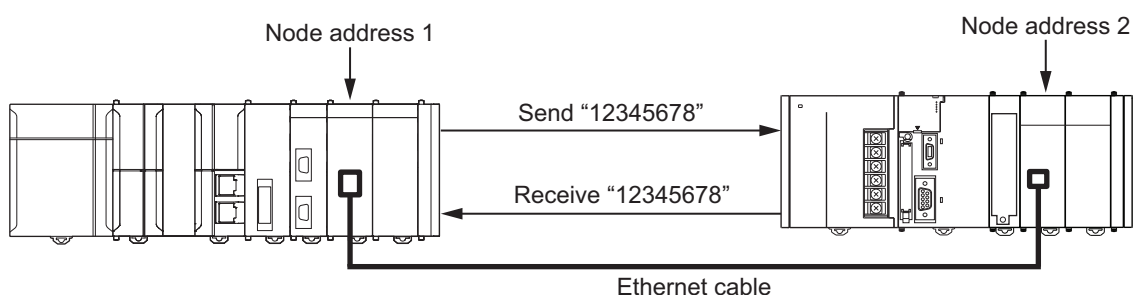

ST

Internal variable	Name	Data type	Initial value	Comment
	Trigger	BOOL	FALSE	Execution condition

Internal variable	Name	Data type	Initial value	Comment
	DoFinsTrigger	BOOL	FALSE	Processing
	SendExecute	BOOL	FALSE	Send instruction execution flag
	RcvExecute	BOOL	FALSE	Rcv instruction execution flag
	State	SINT	0	Sample programming status
	InDNetAdr	_sDNET_ADR	NetNo:=0, NodeNo:=0, UnitNo:=16#0	Network address at send destination
	InOption	_sRESPONSE	isNonResp:=FALSE, TimeOut:=0, Retry:=0	Response
	SrcDat	ARRAY [0..1] OF WORD	[2(16#0)]	Send data
	DstDat	ARRAY [0..1] OF WORD	[2(16#0)]	Receive data
	SendInstance	Send		Send instance
	RcvInstance	Rcv		Rcv instance

External variable	Name	Data type	Comment
	_Port_isAvailable	BOOL	Network Communications Instruction Enabled Flag

```

IF ( (Trigger=TRUE) AND (DoFinsTrigger=FALSE) AND (_Port_isAvailable=TRUE) ) THEN
  State:= 1;
  DoFinsTrigger:=TRUE;

  SendExecute := FALSE; // Send execution status
  RcvExecute := FALSE; // Rcv execution status
  InDNetAdr.NetNo :=USINT#0; // Set network address.
  InDNetAdr.NodeNo :=USINT#2;
  InDNetAdr.UnitNo :=BYTE#16#0;
  InOption.isNonResp :=FALSE; // Set
  InOption.TimeOut :=UINT#20;
  InOption.Retry :=USINT#2;
  SrcDat[0] :=WORD#16#1234; // Set command array.
  SrcDat[1] :=WORD#16#5678;
END_IF;

IF (DoFinsTrigger=TRUE) THEN
  SendInstance( Execute := SendExecute,
    DstNetAdr := InDNetAdr,
    CommPort := _NONE,
    SrcDat := SrcDat[0],
    SendSize := 2,
    DstArea := _DM,
    DstCh := 100,
    Option := InOption);

  RcvInstance ( Execute := RcvExecute,

```

```

SrcNetAdr := InDNetAdr,
CommPort := _NONE,
SrcArea := _DM,
SrcCh := 100,
RcvSize := 2,
DstDat := DstDat[0],
Option := InOption);

CASE State OF
1: // Execute Send.
    SendExecute := TRUE;
    IF (SendInstance.Done=TRUE) THEN
        State := 2;
    ELSIF (SendInstance.Error=TRUE) THEN
        State := 99;
    END_IF;

2: // Execute Rcv.
    RcvExecute := TRUE;
    IF (RcvInstance.Done=TRUE) THEN
        State := 3;
    ELSIF (RcvInstance.Error=TRUE) THEN
        State := 99;
    END_IF;

3: // Normal processing
    Trigger := FALSE;
    DoFinsTrigger:=FALSE;

99: // Abnormal processing
    Trigger := FALSE;
    DoFinsTrigger:=FALSE;
END_CASE;
END_IF;

```

SendCmd

Issues a desired command and receives a response.

Instruction	Name	FB/ FUN	Graphic expression	ST expression
SendCmd	Send Command	FB		SendCmd_instance(Execute, DstNetAdr, CommPort, CmdDat, CmdSize, RespDat, Option, Done, Busy, Error, ErrorID, ErrorIDEx);

Variables

	Meaning	I/O	Description	Valid range	Unit	Default
DstNetAdr	Destination network address	Input	Destination network address	---	---	---
CommPort	Destination serial port		Destination serial port	_NONE		_NONE
CmdDat[] (array)	Command array		Command to send	Depends on data type.		*1
CmdSize	Command data size		Command data size	0 to max. data length *2	Bytes	2
Option	Response		Response monitoring and retry specifications	---	---	---
RespDat[] (array)	Response storage array	In-out	Array to store response	Depends on data type.	---	---

*1. If you omit an input parameter, the default value is not applied. A building error will occur.

*2. This may vary depending on the network type.

	Boo lean	Bit strings				Integers								Real numbers		Times, durations, dates, and text strings					
	BOOL	BYTE	WORD	DWORD	LWORD	USINT	UINT	UDINT	ULINT	SINT	INT	DINT	LINT	REAL	LREAL	TIME	DATE	TOD	DT	STRING	
DstNetAdr																					
CommPort																					
CmdDat[] (array)		OK																			
CmdSize							OK														
Option																					
RespDat[] (array)		OK																			

Function

The SendCmd instruction sends the contents of command array CmdDat[] to the destination specified with destination network address *DstNetAdr* and destination serial port *CommPort*.

The command data size *CmdSize* specifies how many elements of CmdDat[] contain the command.

The response that is returned is stored in response storage array RespDat[].

The data type of *DstNetAdr* is structure `_sDNET_ADR`. The specifications are as follows:

Name	Meaning	Description	Data type	Valid range	Unit	Default
DstNetAdr	Destination network address	Destination network address	<code>_sDNET_ADR</code>	---	---	---
NetNo	Network address	Network address	USINT	0 to 127	---	0
NodeNo	Node address	Node address	USINT	Depends on data type.		
UnitNo	Unit address	Unit address	BYTE	Depends on data type.		

The data type of *CommPort* is enumerated type `_ePORT`.

The meanings of the enumerators of enumerated type `_ePORT` are as follows:

Enumerators	Meaning
<code>_NONE</code>	The destination is not a serial port in Host Link Mode.

The data type of *Option* is structure `_sRESPONSE`. The specifications are as follows:

Name	Meaning	Description	Data type	Valid range	Unit	Default
Option	Response	Response monitoring and retry specifications	<code>_sRESPONSE</code>	---	---	---
isNonResp	No response	TRUE: Response is not required. FALSE: Response is required.	BOOL	Depends on data type.	---	FALSE
TimeOut	Timeout time	Timeout time 0: 2.0 s	UINT		0.1 s	20 (2.0 s)
Retry	Retry count	Retry count	USINT	0 to 15	Time s	0

If no response is returned within the timeout time *Option.TimeOut* when the value of the Response Not Necessary Flag *Option.isNonResp* is FALSE, the command is retried until the response is returned.

The retry count is specified by *Option.Retry*.

The timeout time is *Option.TimeOut* multiplied by 0.1 s. However, if the value of *Option.TimeOut* is 0, the timeout time is 2.0 s. The default value of *Option.TimeOut* is 2.0 s.

Related System-defined Variables

Name	Meaning	Data type	Description
_Port_numUsingPort	Number of Used Ports	USINT	This is the number of ports that are currently used.
_Port_isAvailable	Network Communications Instruction Enabled Flag	BOOL	TRUE: A port is available. FALSE: A port is not available.

Precautions for Correct Use

- This instruction can be executed only when there is an available port. Therefore, use the system-defined variable *_Port_isAvailable* (Network Communications Instruction Enabled Flag) in an N.O. execution condition for the instruction.
- The command is not sent if the value of *CmdSize* is 0. In that case, the value of *Done* changes to TRUE.
- During execution of this instruction, set *Option.Retry* to a value other than 0 by considering the case when the send message or response is lost due to noise that occurs during communication. If no response is returned within *Option.TimeOut*, try to resend the message.
- Refer to the *CS/CJ/CP/NSJ-series Communications Commands Reference Manual (Cat. No. W342)* for specification of network address.
The FINS routing specification in the NX-series CPU Units differ from those in the CS/CJ-series CPU Units.
Refer to *A-1 Difference Between CS/CJ-series and NX-series in FINS Routing* on page A-2 for information on differences in routing specification.
- When this instruction is written in the ST program, make sure that the instruction is executed for each task period during execution of this instruction. Otherwise, normal processing may not be possible.
- You cannot use this instruction in an event task. A compiling error will occur.
- The maximum number of Send, Rcv, and SenCmd instructions that can be executed simultaneously is 32.
- An error will occur in the following cases. *Error* will change to TRUE.
 - a) A member of *DstNetAdr* is outside of its range.
 - b) *CmdSize* is outside of its range.
 - c) The value of *CmdSize* exceeds the size of *CmdDat[]*.
 - d) A member of *Option* is outside of its range.
 - e) The response size exceeds the size of *RespDat[]*.
 - f) The value of *_Port_isAvailable* is FALSE.
 - g) Communications fail.
 - h) The **Do not use** option is selected for FINS/UDP and FINS/TCP connection has not been established.
 - i) More than 32 Send, Rcv, and SendCmd instructions are executed simultaneously.
- If the value of Error code "Error ID" is WORD#16#0800, the expansion error code "ErrorIDEx" has the meaning of end code for the communication command in this instruction.
Refer to *End Codes in 5-1 Command Lists* of the *SYSMAC CS/CJ/CP/NSJ-series Communications Commands Reference Manual (Cat. No. W342)* for details.

Sample Programming

In this sample, the SendCmd instruction sends CPU UNIT DATA READ command from the network No. 0, node No. 2, Unit No. 0 and receives the data.

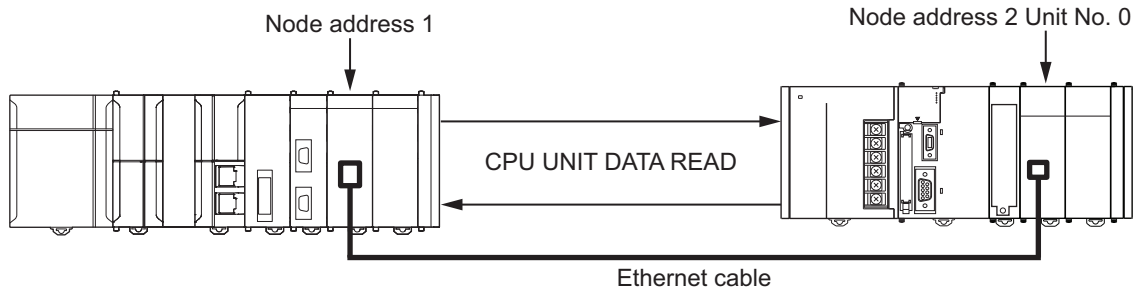

ST

Internal Variables	Name	Data type	Initial value	Comment
	Trigger	BOOL	FALSE	Execution condition
	DoFinsTrigger	BOOL	FALSE	Processing
	SendCmdExecute	BOOL	FALSE	SendCmd instruction execution flag
	State	SINT	0	Sample programming status
	InDNetAdr	_sDNET_ADR	NetNo:=0, NodeNo:=0, UnitNo:=16#0	Network address at send destination
	InOption	_sRESPONSE	isNonResp:=FALSE, TimeOut:=0, Retry:=0	Response
	CmdDat	ARRAY[0..1] OF BYTE	[2(16#0)]	Send data
	RespDat	ARRAY[0..1023] OF BYTE	[1024(16#0)]	Receive data
	SendCmdInstance	SendCmd		SendCmd instance

External variable	Name	Data type	Comment
	_Port_isAvailable	BOOL	Network Communications Instruction Enabled Flag

```

IF ( (Trigger=TRUE) AND (DoFinsTrigger=FALSE) AND (_Port_isAvailable=TRUE) ) THEN
  State:= 1;
  DoFinsTrigger:=TRUE;

  SendCmdExecute := FALSE; // Send execution status
  InDNetAdr.NetNo :=USINT#0; // Set network address.
  InDNetAdr.NodeNo :=USINT#2;
  InDNetAdr.UnitNo :=BYTE#16#0;
  InOption.isNonResp :=FALSE; // Set response.
  InOption.TimeOut :=UINT#20;
  InOption.Retry :=USINT#2;

```

```
    CmdDat[0] :=BYTE#16#05; // Set command array.
    CmdDat[1] :=BYTE#16#01;
END_IF;

IF (DoFinsTrigger=TRUE) THEN
    SendCmdInstance( Execute :=SendCmdExecute,
        DstNetAdr:=InDNetAdr,
        CommPort :=_NONE,
        CmdDat := CmdDat [0],
        CmdSize :=UINT#2,
        RespDat := RespDat [0],
        Option :=InOption);

CASE State OF
    1: // Execute SendCmd.
        SendCmdExecute := TRUE;
        IF (SendCmdInstance.Done=TRUE) THEN
            State := 2;
        ELSIF (SendCmdInstance.Error=TRUE) THEN
            State := 99;
        END_IF;

    2: // Normal processing
        Trigger := FALSE;
        DoFinsTrigger:=FALSE;

    99: // Abnormal processing
        Trigger := FALSE;
        DoFinsTrigger:=FALSE;
END_CASE;
END_IF;
```



Troubleshooting

This section describes the errors that may occur during communications with CPU Units.

4-1	Troubleshooting	4-2
-----	-----------------------	-----

4-1 Troubleshooting

Refer to *End Codes in 5-1 Command Lists* of the *SYSMAC CS/CJ/CP/NSJ-series Communications Commands Reference Manual (Cat. No. W342)* for details about the errors that may occur during communications with CPU Units.

Refer to the manual of each relevant unit for details about the errors that may occur during communications with other OMRON Units.



Appendices

A-1	Difference Between CS/CJ-series and NX-series in FINS Routing.....	A-2
A-1-1	Communication When 0 Is Specified for the Destination Network Address....	A-2
A-1-2	Operation of Routing Table during Clear All Memory Operation	A-4

A

A-1 Difference Between CS/CJ-series and NX-series in FINS Routing

The FINS routing specification settings in the NX-series CPU Units differ from those in the CS/CJ-series CPU Units by the following points:

- Communication when 0 is specified for the destination network address
- Operation of the routing table during Clear All Memory operation.

A-1-1 Communication When 0 Is Specified for the Destination Network Address

The communication may vary depending on the CPU Unit as described below.

CPU Unit	Operation
NX Series	Routing of the network of the built-in EtherNet/IP port.
CS/CJ Series	Routing of the network of the Communications Unit that has the smallest unit number among the installed CS/CJ-series Special Units.



Additional Information

For the CS/CJ-series CPU Units, the FINS command is issued to the network of the FINS network Communications Unit that has the smallest unit number.

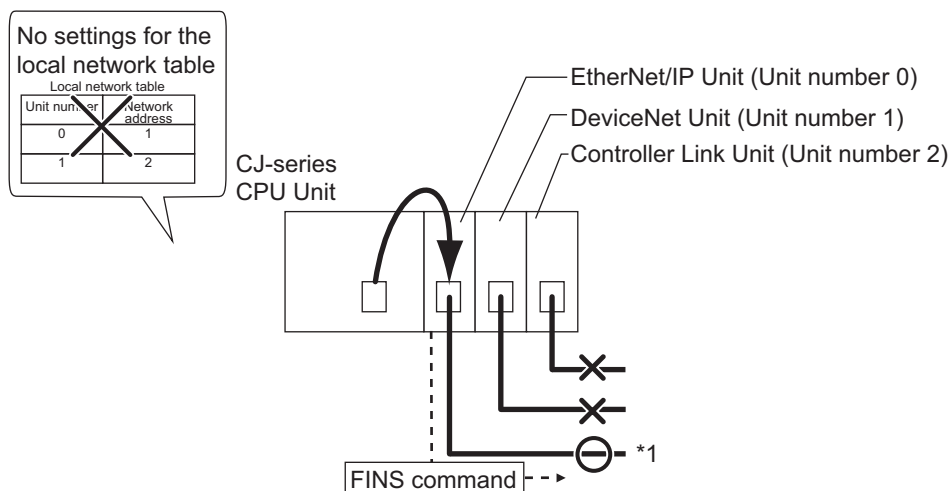

*1. When the FINS command specified with network address 0 and node address n is issued to a CPU Unit with no local network table specified, the FINS command is issued to the FINS network of the lowest unit number.

When the opposite unit is the CS/CJ-series CPU Unit and 0 is specified for the destination network address, the communication may or may not be possible as described below.

Communication is possible when network number 0 is specified

- When only one FINS network Communications Unit is connected to the opposite CS/CJ-series CPU Unit.
- When multiple FINS network Communications Units are connected to the opposite CS/CJ-series CPU Units, and the FINS network Communications Unit is connected to the CS/CJ-series CPU Unit that has the smallest unit number.

In this case, the routing table setting is not required for the NX-series CPU Unit.

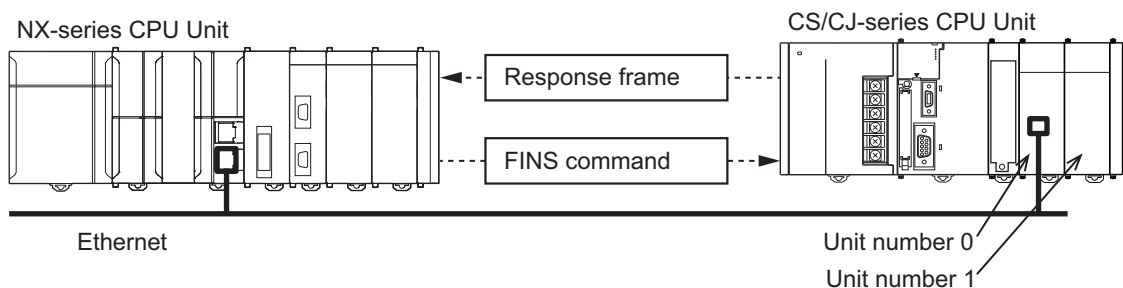

Communication is not possible when network number 0 is specified

- When multiple FINS network Communications Units are connected to the opposite CS/CJ-series CPU Units, and the FINS network Communication Unit is connected to a CS/CJ-series CPU Unit other than the unit that has the smallest unit number.

In this case, routing table setting is required for both the NX-series CPU Unit and the CS/CJ-series CPU Unit.

A

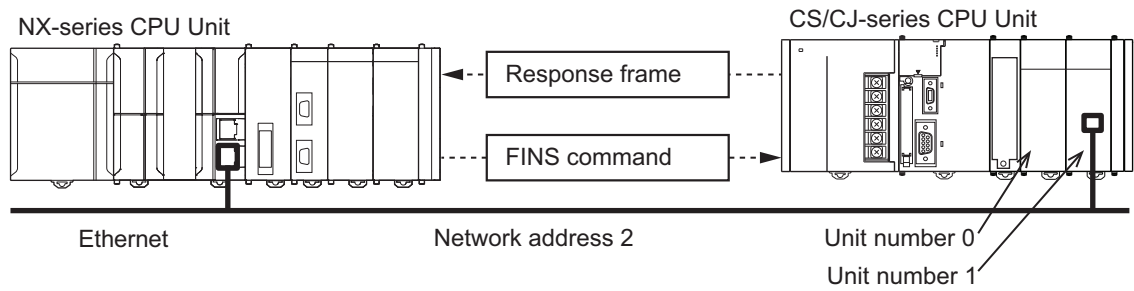

The example below shows the routing table setting for the NX-series CPU Unit.

FINS Routing Table				
Local Network Table				
No.	Unit Type	Unit No.	Unit/Port	Local Network
1	Built-in EtherNet/IP Port	250	Unit	2

The example below shows the routing table setting for the CS/CJ-series CPU Unit.

[Local network table]

No.	Local network table	Unit number
1	1	0
2	2	1
3		

A-1-2 Operation of Routing Table during Clear All Memory Operation

During Clear All Memory operation of the NX-series CPU Units, the routing table is cleared together with the local network table and relay network table.



Index

Index

R

Rcv (Receive from Network).....	3-10
Receive from Network.....	3-10

S

Send (Send to Network).....	3-6
Send Command.....	3-16
Send to Network.....	3-6
SendCmd (Send Command).....	3-16

V

version.....	16
--------------	----

OMRON Corporation Industrial Automation Company

Kyoto, JAPAN

Contact : www.ia.omron.com

Regional Headquarters

OMRON EUROPE B.V.

Wegalaan 67-69, 2132 JD Hoofddorp
The Netherlands

Tel: (31) 2356-81-300 Fax: (31) 2356-81-388

OMRON ASIA PACIFIC PTE. LTD.

438B Alexandra Road, #08-01/02 Alexandra
Technopark, Singapore 119968

Tel: (65) 6835-3011 Fax: (65) 6835-3011

OMRON ELECTRONICS LLC

2895 Greenspoint Parkway, Suite 200
Hoffman Estates, IL 60169 U.S.A.

Tel: (1) 847-843-7900 Fax: (1) 847-843-7787

OMRON (CHINA) CO., LTD.

Room 2211, Bank of China Tower,
200 Yin Cheng Zhong Road,
PuDong New Area, Shanghai, 200120, China

Tel: (86) 21-6023-0333 Fax: (86) 21-5037-2388

Authorized Distributor:

©OMRON Corporation 2018-2024 All Rights Reserved.
In the interest of product improvement,
specifications are subject to change without notice.

Cat. No. W596-E1-05 0724