

Simple, Compact Inverters JX-series

Replace Guide From 3G3JX to 3G3MX2

3G3MX2-A□□□□

3G3JX-A□□□□

Replace
Guide

NOTE

All rights reserved. No part of this publication may be reproduced, stored in a retrieval system, or transmitted, in any form, or by any means, mechanical, electronic, photocopying, recording, or otherwise, without the prior written permission of OMRON.

No patent liability is assumed with respect to the use of the information contained herein. Moreover, because OMRON is constantly striving to improve its high-quality products, the information contained in this manual is subject to change without notice.

Every precaution has been taken in the preparation of this manual. Nevertheless, OMRON assumes no responsibility for errors or omissions. Neither is any liability assumed for damages resulting from the use of the information contained in this publication.

Introduction

This guide provides the reference information for replacement and does not contain safety information and other details that are required for actual use. Thoroughly read and understand the manuals for both the old and new inverters to ensure that the system is used safely. Review the entire contents of these manuals, including all safety precautions, precautions for safe use, and precautions for correct use.

Intended Audience

This guide is intended for the following personnel.

- Personnel in charge of introducing control equipment
- Personnel in charge of designing control systems
- Personnel in charge of installing and maintaining control equipment
- Personnel in charge of managing control systems and facilities

The personnel must also have the following knowledge.

- Knowledge of electrical systems (an electrical engineer or the equivalent)

Applicable Products

This guide covers the following products.

- 3G3JX series Inverter
- 3G3MX2 series Type V1 Inverter

Terms and Conditions Agreement

Warranties.

(a) Exclusive Warranty. Omron's exclusive warranty is that the Products will be free from defects in materials and workmanship for a period of twelve months from the date of sale by Omron (or such other period expressed in writing by Omron). Omron disclaims all other warranties, express or implied.

(b) Limitations. OMRON MAKES NO WARRANTY OR REPRESENTATION, EXPRESS OR IMPLIED, ABOUT NON-INFRINGEMENT, MERCHANTABILITY OR FITNESS FOR A PARTICULAR PURPOSE OF THE PRODUCTS. BUYER ACKNOWLEDGES THAT IT ALONE HAS DETERMINED THAT THE PRODUCTS WILL SUITABLY MEET THE REQUIREMENTS OF THEIR INTENDED USE.

Omron further disclaims all warranties and responsibility of any type for claims or expenses based on infringement by the Products or otherwise of any intellectual property right. (c) Buyer Remedy. Omron's sole obligation hereunder shall be, at Omron's election, to (i) replace (in the form originally shipped with Buyer responsible for labor charges for removal or replacement thereof) the non-complying Product, (ii) repair the non-complying Product, or (iii) repay or credit Buyer an amount equal to the purchase price of the non-complying Product; provided that in no event shall Omron be responsible for warranty, repair, indemnity or any other claims or expenses regarding the Products unless Omron's analysis confirms that the Products were properly handled, stored, installed and maintained and not subject to contamination, abuse, misuse or inappropriate modification. Return of any Products by Buyer must be approved in writing by Omron before shipment. Omron Companies shall not be liable for the suitability or unsuitability or the results from the use of Products in combination with any electrical or electronic components, circuits, system assemblies or any other materials or substances or environments. Any advice, recommendations or information given orally or in writing, are not to be construed as an amendment or addition to the above warranty.

See <http://www.omron.com/global/> or contact your Omron representative for published information.

Limitation on Liability; Etc.

OMRON COMPANIES SHALL NOT BE LIABLE FOR SPECIAL, INDIRECT, INCIDENTAL, OR CONSEQUENTIAL DAMAGES, LOSS OF PROFITS OR PRODUCTION OR COMMERCIAL LOSS IN ANY WAY CONNECTED WITH THE PRODUCTS, WHETHER SUCH CLAIM IS BASED IN CONTRACT, WARRANTY, NEGLIGENCE OR STRICT LIABILITY.

Further, in no event shall liability of Omron Companies exceed the individual price of the Product on which liability is asserted.

Suitability of Use.

Omron Companies shall not be responsible for conformity with any standards, codes or regulations which apply to the combination of the Product in the Buyer's application or use of the Product. At Buyer's request, Omron will provide applicable third party certification documents identifying ratings and limitations of use which apply to the Product. This information by itself is not sufficient for a complete determination of the suitability of the Product in combination with the end product, machine, system, or other application or use. Buyer shall be solely responsible for determining appropriateness of the particular Product with respect to Buyer's application, product or system. Buyer shall take application responsibility in all cases.

NEVER USE THE PRODUCT FOR AN APPLICATION INVOLVING SERIOUS RISK TO LIFE OR PROPERTY OR IN LARGE QUANTITIES WITHOUT ENSURING THAT THE SYSTEM AS A WHOLE HAS BEEN DESIGNED TO ADDRESS THE RISKS, AND THAT THE OMRON PRODUCT(S) IS PROPERLY RATED AND

INSTALLED FOR THE INTENDED USE WITHIN THE OVERALL EQUIPMENT OR SYSTEM.

Programmable Products.

Omron Companies shall not be responsible for the user's programming of a programmable Product, or any consequence thereof.

Performance Data.

Data presented in Omron Company websites, catalogs and other materials is provided as a guide for the user in determining suitability and does not constitute a warranty. It may represent the result of Omron's test conditions, and the user must correlate it to actual application requirements. Actual performance is subject to the Omron's Warranty and Limitations of Liability.

Change in Specifications.

Product specifications and accessories may be changed at any time based on improvements and other reasons. It is our practice to change part numbers when published ratings or features are changed, or when significant construction changes are made. However, some specifications of the Product may be changed without any notice. When in doubt, special part numbers may be assigned to fix or establish key specifications for your application. Please consult with your Omron's representative at any time to confirm actual specifications of purchased Product.

Errors and Omissions.

Information presented by Omron Companies has been checked and is believed to be accurate; however, no responsibility is assumed for clerical, typographical or proofreading errors or omissions.

Precautions

- When building a system, check the specifications for all devices and equipment that will make up the system and make sure that the OMRON products are used well within their rated specifications and performances. Safety measures, such as safety circuits, must be implemented in order to minimize the risks in the event of a malfunction.
- Thoroughly read and understand the manuals for all devices and equipment that will make up the system to ensure that the system is used safely. Review the entire contents of these manuals, including all safety precautions, precautions for safe use, and precautions for correct use.
- Confirm all regulations, standards, and restrictions that the system must adhere to.

[Trademarks/Copyrights]

Company names and product names in this document are the trademarks or registered trademarks of their respective companies.

Microsoft product screen shot(s) reprinted with permission from Microsoft Corporation.

Related Manuals

Please see the manuals below for related product information. Use these manuals for reference.

Manual name	Cat. No.	Model	Description
3G3JX Series Compact Simplified Inverter User's Manual	I558	3G3JX-□□□□□	Describes how to install and wire the inverter, set parameters needed to operate the inverter, and remedies to be taken and inspection methods to be used in case that problems occur.
3G3MX2 Series Type V1 Multi-function Compact Inverter User's Manual	I585	3G3MX2-□□□□□-V1	Describes how to install and wire the inverter, set parameters needed to operate the inverter, and remedies to be taken and inspection methods to be used in case that problems occur.

Revision History

A manual revision code appears as a suffix to the catalog number on the front and back covers of the manual.



Revision code	Date	Revised content
01	July 2019	Original production

Index

Introduction	3
Intended Audience	3
Applicable Products	3
Terms and Conditions Agreement	4
Precautions	6
Related Manuals	7
Revision History	8
1. Target model	10
2. Precautions for replacement	11
3. External Dimensions and Mounting dimensions	12
3.1. External Dimensions	12
3.2. External Dimensions	13
4. Arrangement and Function of Terminal Block	17
4.1. Control Circuit Terminal Block	17
5. Functional difference	19
5.1. Dual duty rating	19
5.2. Modbus communication	19
6. Parameter List	20
6.1. The difference of parameter arrangement, parameter name and default value	20
6.2. The difference of multi-function Input Settings	21
6.3. The difference of multi-function Output Settings	22
7. Modbus Communication Data Correspondence List	23
7.1. Coil Number	23
7.2. Register Number	24

1. Target model

(1) Replaced (old) model

3G3JX series Compact Simplified Inverter

3G3JX-□□□□□

(2) New model

3G3MX2 Series Type V1 Multi-function Compact Inverter

3G3MX2-□□□□□-V1

2. Precautions for replacement

- (1) There are some differences between 3G3JX and 3G3MX2-V1. Before replacement, refer to not only this guide but also related product user's manuals.
- (2) 3G3JX has a 3-phase 400-V class 3.7 kW capacitor model. Please replace with a 3-phase 400-V class 4.0 kW capacitor model.
- (3) 3G3JX has single/3-phase 200-V class models. Please replace with single-phase 200-V class models or 3-phase 200-V class models.
- (4) There are some differences between 3G3JX and 3G3MX2-V1 in mounting dimensions and arrangement and function of terminal block. Refer to related product user's manuals.
- (5) For differences between 3G3JX and 3G3MX2-V1 in default parameter values and parameter functions, refer to this guide. For details of functions, refer to related product user's manuals at the time of setting.
- (6) There is no volume control on 3G3MX2-V1. To input commands with the volume control, please use the optional operator 3G3AX-OP01.
- (7) To connect the CX-Drive and 3G3MX2-V1, please use a commercially available USB cable. The 3G3JX dedicated cable 3G3AX-PCAN2 cannot be used with 3G3MX2-V1.
- (8) 3G3JX has a built-in radio noise filter. To use 3G3MX2-V1 under the same installation conditions, please attach an optional radio noise filter.
- (9) Please note that the program of the host controller needs to be changed when replacing 3G3JX using Modbus communication. The digital operator for 3G3JX cannot be used for 3G3MX2-V1.

3. External Dimensions and Mounting dimensions

The following tables show external dimensions and mounting dimensions of 3G3JX and 3G3MX2-V1. You can install multiple 3G3MX2-V1s side by side like 3G3JXs. Note that the external dimensions of 3G3MX2-V1 are smaller than or equal to 3G3JX but the depths (D) of all 3G3MX2-V1 models and the heights (H) of over 5.5 kW models of 3G3MX2-V1 are larger than 3G3JX.

3.1. External Dimensions

■ 3-phase 200-V class*1

3G3JX Series							3G3MX2-V1 Series						
Model 3G3JX-	Dimensions (mm)			Mounting dimensions (mm)			Model 3G3MX2-	Dimensions (mm)			Mounting dimensions (mm)		
	W	H	D	W1	H1	Screw hole		W	H	D	W1	H1	Screw hole
A2002	80	155	97.4	67	143	Φ5	A2002-V1	68	128	109	56	118	Φ4.5
A2004	80	155	111.4	67	143	Φ5	A2004-V1	68	128	122.5	0	0	Φ4.5
A2007	80	155	134.4	67	143	Φ5	A2007-V1	68	128	145.5	0	0	Φ4.5
A2015	110	189	159.4	98	176	Φ5	A2015-V1	108	128	170.5	0	0	Φ4.5
A2022	110	189	159.4	98	176	Φ5	A2022-V1	108	128	170.5	0	0	Φ4.5
A2037	110	189	159.4	98	176	Φ5	A2037-V1	140	128	170.5	0	0	Φ4.5
A2055	180	250	169.4	164	235	Φ6	A2055-V1	140	260	155	0	0	Φ6
A2075	180	250	169.4	164	235	Φ6	A2075-V1	140	260	155	0	0	Φ6

■ 3-phase 400-V class

3G3JX Series							3G3MX2-V1 Series						
Model 3G3JX -	Dimensions (mm)			Mounting dimensions (mm)			Model 3G3MX2-	Dimensions (mm)			Mounting dimensions (mm)		
	W	H	D	W1	H1	Screw hole		W	H	D	W1	H1	Screw hole
A4004	110	189	132.4	98	176	Φ5	A4004-V1	108	128	143.5	96	118	Φ4.5
A4007	110	189	159.4	98	176	Φ5	A4007-V1	108	128	170.5	96	118	Φ4.5
A4015	110	189	159.4	98	176	Φ5	A4015-V1	108	128	170.5	96	118	Φ4.5
A4022	110	189	159.4	98	176	Φ5	A4022-V1	108	128	170.5	96	118	Φ4.5
A4037	110	189	159.4	98	176	Φ5	A4040-V1	140	128	170.5	128	118	Φ4.5
A4055	180	250	169.4	164	235	Φ6	A4055-V1	140	260	155	122	248	Φ6
A4075	180	250	169.4	164	235	Φ6	A4075-V1	140	260	155	122	248	Φ6.

■ Single-phase 200-V class*2

3G3JX Series							3G3MX2-V1 Series						
Model 3G3JX -	Dimensions (mm)			Mounting dimensions (mm)			Model 3G3MX2-	Dimensions (mm)			Mounting dimensions (mm)		
	W	H	D	W1	H1	Screw hole		W	H	D	W1	H1	Screw hole
AE002	80	155	97.4	67	143	Φ5	AB002-V1	68	128	109	56	118	Φ4.5
AE004	80	155	111.4	67	143	Φ5	AB004-V1	68	128	122.5	56	118	Φ4.5
AE007	110	189	132.4	98	176	Φ5	AB007-V1	108	128	170.5	96	118	Φ4.5

AE015	110	189	159.4	98	176	Φ 5	AB015-V1	108	128	170.5	96	118	Φ 4.5
AE022	110	189	159.4	98	176	Φ 5	AB022-V1	108	128	170.5	96	118	Φ 4.5

- *1. When using 3G3JX-AE□ with 3-phase 200 V input, select from 3G3MX2-V1 3-phase 200 V input specifications.
- *2. When using 3G3JX-AE□ with single-phase 200 V input, select from 3G3MX2-V1 single-phase 200 V input specifications.

3.2. External Dimensions

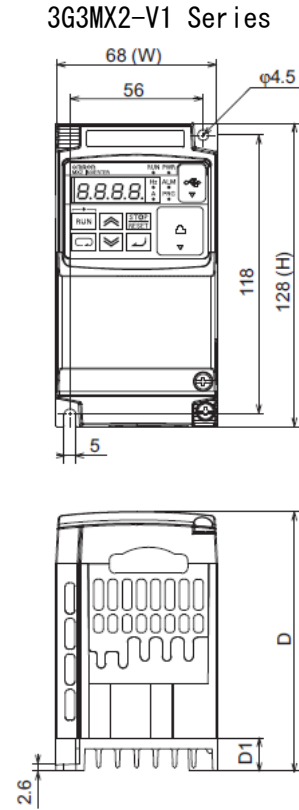
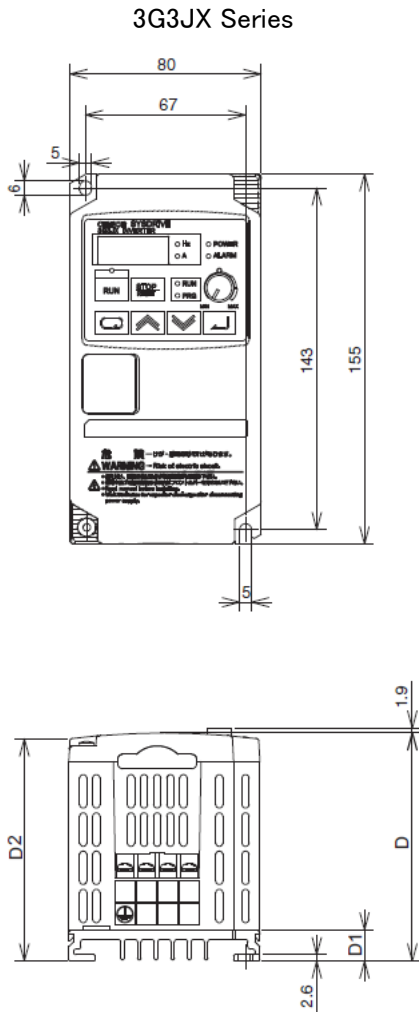

Model 3G3JX-	D [mm]	D1 [mm]	D2 [mm]
A2002	95.5	13	93
AE002			
A2004	109.5	27	107
AE004			
A2007	132	50	130

Model 3G3MX2-	D [mm]	D1 [mm]
A2002-V1	109	13.5
AB002-V1		
A2004-V1	122.5	27
AB004-V1		
A2007-V1	145.5	50

3G3JX Series

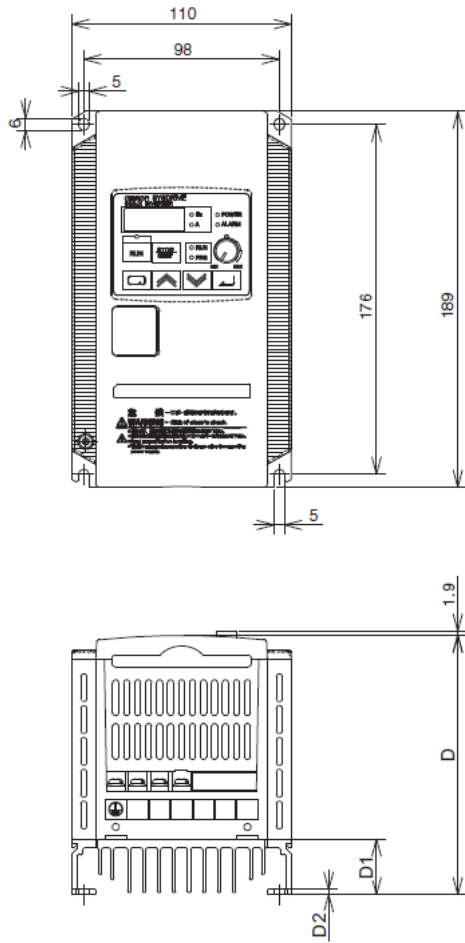

3G3MX2-V1 Series

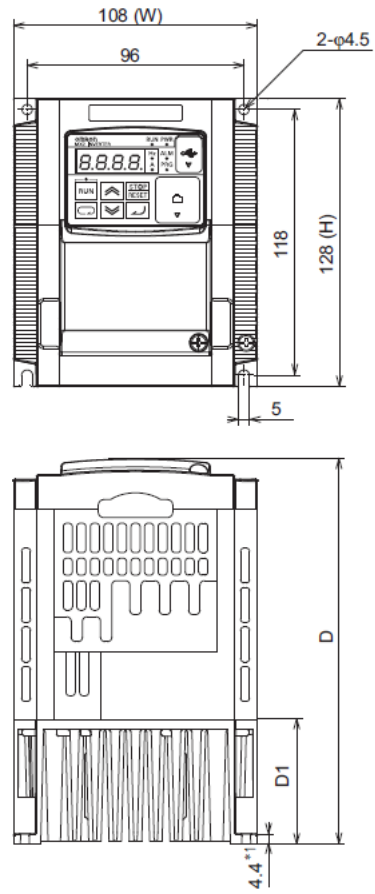

Model 3G3JX-	D [mm]	D1 [mm]	D2 [mm]
A4004	130.5	28	2.6
AE007			
A2015	157.5	55	6
A2022			
A4007			
A4015			
A4022			
AE015			
AE022			

Model 3G3MX2-	D [mm]	D1 [mm]
A4004-V1	143.5	28
A2015-V1	170.5	55
A2022-V1		
A4007-V1		
A4015-V1		
A4022-V1		
AB007-V1		
AB015-V1		
AB022-V1		

3G3JX Series

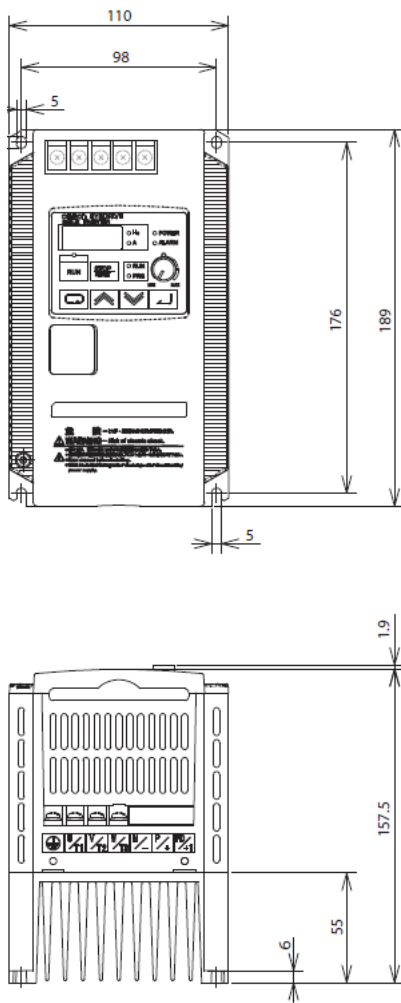

Model
3G3JX-
A2037
A4037

3G3MX2-V1 Series

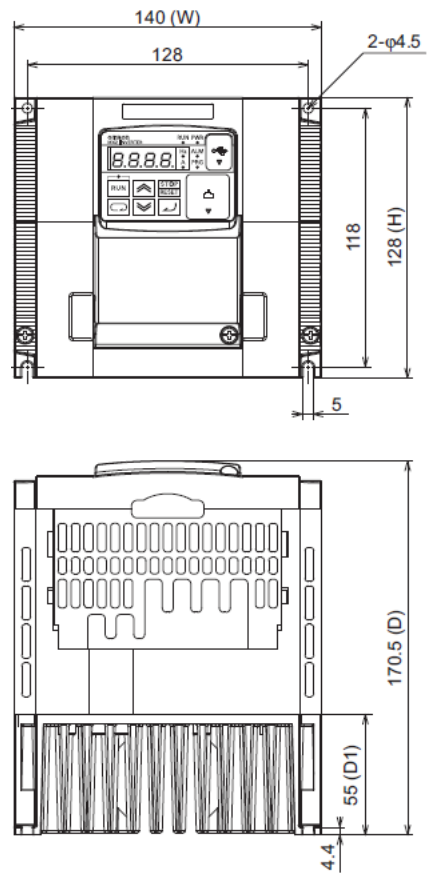

Model
3G3MX2-
A2037-V1
A4040-V1

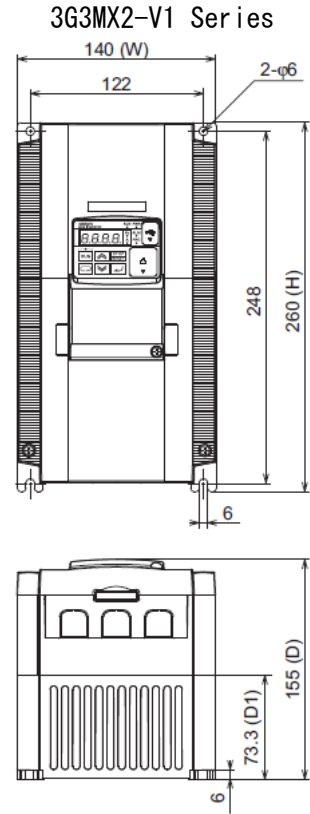
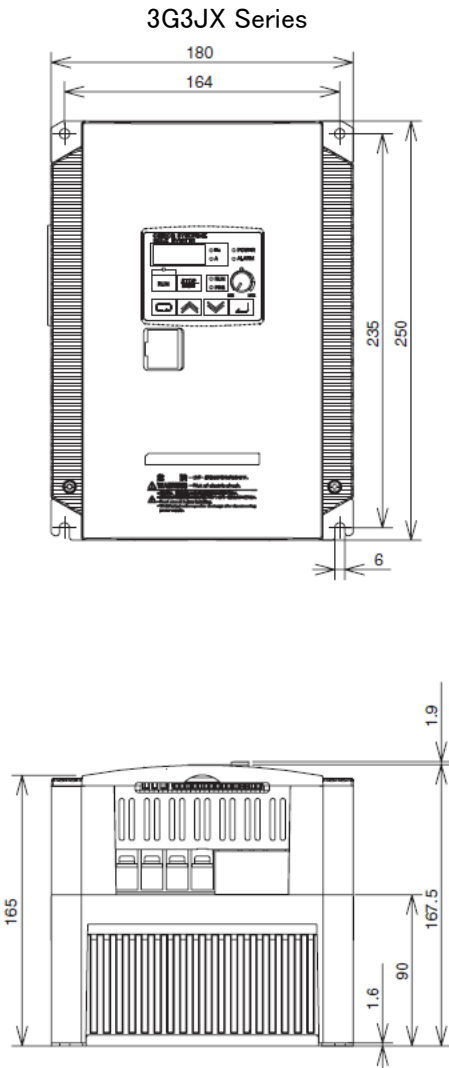

Model
3G3JX-
A2055
A2075
A4055
A4075

Model
3G3MX2-
A2055-V1
A2075-V1
A4055-V1
A4075-V1

4. Arrangement and Function of Terminal Block

There are some difference of Arrangement and Function of Terminal Block between 3G3JX and 3G3MX2-V1. Before setting, to refer this section. Refer to related product user's manual.

4.1. Control Circuit Terminal Block

3G3JX		3G3MX2-V1		Remarks
Terminal	Terminal name	Terminal	Terminal name	
P24	Internal 24 VDC	P24	Internal 24 VDC	
PSC	Input terminal power supply	PSC	Input terminal power supply	For sink logic input: Short-circuited to P24 For source logic input: Short-circuited to SC. To activate contact input via an external power supply, remove the short-circuit bar.
S1 S2 S3 S4	Multi-function input	S1 S2 S3 S4	Multi-function input	The terminals S3 and S4 are shared with the safety input. When the safety function selector switch is ON, S3 and S4 are automatically set to safety input (GS1, GS2).
S5	Multi-function input	S5 (TH)	Multi-function input (External thermistor input used in common)	When the Multi-function Input S5 Selection (C005) is set to 19 (TH: PTC thermistor thermal protection), the inverter will trip if the external thermistor detects a temperature error. (The inverter trips when the resistance of the thermistor is approximately 3 k Ω or higher.)
SC	Input signal common	SC	Input signal common	
AM	Analog frequency monitor/Analog output current monitor	AM	Multi-function analog output (Voltage)	This terminal can output the specified signal as a 0 to 10-VDC voltage signal.
FS	Frequency reference power supply	FS	Frequency reference power supply	
FV	Voltage frequency reference signal	FV	Voltage frequency reference signal	Frequency reference input (Analog voltage input)

FI	Current frequency reference signal	FI	Current frequency reference signal	Frequency reference input (Analog current input)
FC	Frequency reference common	SC	Input signal common	In 3G3MX2-V1, common terminal for the internal power supply, digital input, and analog I/O terminals.
P1	Multi-function output terminal	P1	Multi-function output terminal (Safety monitor terminal used in common)	This terminal is automatically set to P1 (EDM: Safety monitor signal) when the EDM function selector switch is turned ON.
PC	Output signal common	PC	Output signal common	
MA MB	Relay output signal	MA MB	Relay output terminal	
MC		MC	Relay output common	
SP	Sent and received data: Positive side	RS+	Modbus terminal(+)	In 3G3JX, it is located in the RJ45 connector for digital operator connection.
SN	Sent and received data: Negative side	RS-	Modbus terminal(-)	

5. Functional difference

5.1. Dual duty rating

3G3MX2-V1 supports the dual duty rating: heavy load (CT) and light load (VT) that allows the inverter to drive a motor whose capacity is one size large. Heavy load (CT) is used in this guide.

Heavy load (CT)	This mode is for general loads that temporarily exceed the rated torque during acceleration and deceleration.
Light load (VT)	This mode is for a fan, pump, or other device that operates at the rated motor torque or lower. With a load tolerance of 120% (of rated torque)/min, the inverter can drive a motor that is one size larger.

5.2. Modbus communication

Some Modbus addresses differ between 3G3JX and 3G3MX2-V1.

In order to operate correctly, refer to the *3G3MX2-V1 User's Manual* for the addresses and parameter settings and change not only parameter settings but also PLC/PC programs.

6. Parameter List

6.1. The difference of parameter arrangement, parameter name and default value

There are some difference of Parameter name, settings, number, date range and arrangement between 3G3JX and 3G3MX2-V1. Before setting, to refer this section. Refer to related product user's manuals.

Name	3G3JX		3G3MX2-V1		Remark
	Parameter No.	Default setting	Parameter No.	Default setting	
Frequency reference selection	A001	00: Digital Operator (FREQ adjuster)	A001	02: Digital Operator	The initial value differs because there is no adjuster on 3G3MX-V1.
FV/FI selection	A005	02: Switches between FV/FREQ adjuster via terminal AT	A005	00: Switch between FV (Voltage) and FI (Current)	
Jogging stop selection	A039	00: Free-run stop	A039	04: Deceleration stop on jogging stop/Enabled during operation	Set A039 to 03 to be the same setting as 3G3JX.
Torque boost selection	A041	00: Manual torque boost only	A041	01: Automatic torque boost	In addition to manual torque boost, 3G3MX-V1 has automatic torque boost enabled by default. For applications with excessive starting torque, such as fans or pumps, turn off automatic torque boost.
Manual torque boost voltage	A042	5	A042	1	
Manual torque boost frequency	A043	2.5	A043	5	
Acceleration time 2	A092	15	A092	10	Set A092 to 15 to be the same setting as 3G3JX.
Deceleration time 2	A093	15	A093	10	Set A093 to 15 to be the same setting as 3G3JX.
Acceleration pattern selection	A097	00: Line	A097	01: S-shape curve	Set A097 to 00 to be the same setting as 3G3JX.
Deceleration pattern selection	A098	00: Line	A098	01: S-shape curve	Set A098 to 00 to be the same setting as 3G3JX.
FI start ratio	A103	0	A103	20	Set A103 to 0 to be the same setting as 3G3JX.
FI start selection	A105	01: 0 Hz start	A105	00: FI Start Frequency (A101)	Set A105 to 01 to be the same setting as 3G3JX.
Operation frequency input A setting	A141	01: Digital Operator (FREQ adjuster)	A141	02: Input FV (Voltage)	Set A141 to 01 to be the same setting as 3G3JX.
Operation frequency input B setting	A142	2: FV 入力	A142	03: Input FI (Current)	Set A142 to 02 to be the same setting as 3G3JX.
2nd frequency reference selection	A201	00: Digital Operator (FREQ adjuster)	A201	02: Digital Operator	Set A201 to 00 to be the same setting as 3G3JX.
2nd torque boost selection	A241	00: Manual torque boost only	A241	01: Automatic torque boost	In addition to manual torque boost, 3G3MX-V1 has automatic torque boost enabled by default. For applications with excessive starting torque, such as fans or pumps, turn off automatic torque boost.
2nd manual torque boost voltage	A242	0	A242	1	
2nd manual torque boost frequency	A243	0	A243	5	
2nd acceleration time 2	A292	15	A292	10	Set A292 to 15 to be the same setting as 3G3JX.
2nd deceleration time 2	A293	15	A293	10	Set A293 to 15 to be the same setting as 3G3JX.
Electronic thermal characteristics selection	B013	00: Reduced torque characteristics 1	B013	01: Constant torque characteristics	Set B013 to 00 to be the same setting as 3G3JX.
Starting voltage of non-stop function at momentary power interruption	B051	0	B051	220	Set B051 to 0.0 to be the same setting as 3G3JX.
Stop deceleration level of non-stop function at momentary power interruption	B052	0	B052	360	Set B052 to 0.0 to be the same setting as 3G3JX.
Overvoltage protection integral time during deceleration	B056	0.2	B134	1	Set B134 to 0.2 to be the same setting as 3G3JX.
Carrier frequency	B083	3	B083	10	Set B083 to 3.0 to be the same setting as 3G3JX.
Initialization selection	B084	00: Clears the trip monitor	B084	00: Initialization disabled	Set B084 to 01 to be the same setting as 3G3JX.
Overvoltage LAD stop function level setting	B131	380	B096	360	Set B096 to 380 to be the same setting as 3G3JX.
2nd electronic thermal characteristics selection	B213	00: Reduced torque characteristics 1	B213	01: Constant torque characteristics	Set B213 to 00 to be the same setting as 3G3JX.
Overvoltage protection function selection during deceleration	B133	00: Disabled	B130	01: Enabled (DC voltage kept constant)	Set B130 to 00 to be the same setting as 3G3JX.
Automatic carrier reduction	B150	00: Disabled	B089	01: Enabled (dependent on current)	Set B089 to 0 to be the same setting as 3G3JX.
AM selection	C028	00: Output frequency	C028	07: LAD frequency	Set C028 to 00 to be the same setting as 3G3JX.
Overload warning level	C041	1.4	C041	1.84	Set C041 to rated current to be the same setting as 3G3JX.
Communication speed selection (Baud rate selection)	C071	4: 4800bps	C071	5: 9600bps	Set C071 to 04 to be the same setting as 3G3JX.
Reset selection	C102	00: Trip reset at power-on	C102	02: Enabled only during trip (Reset at power-on)	Set C102 to 00 to be the same setting as 3G3JX.
Logic operation function B input	C142	01: FA1 (constant speed arrival signal)	C143	00: RUN (Signal during RUN)	Set C143 to 02 to be the same setting as 3G3JX.
Output frequency setting/monitor	F001	0	F001	6	Set F001 to 0 to be the same setting as 3G3JX.

6.2. The difference of multi-function Input Settings

There are some difference of multi-function Input Settings between 3G3JX and 3G3MX2-V1. Before setting, to refer the following list. Refer to related product user's manuals.

Data No.	3G3JX		3G3MX2-V1	
	Code	Function name	Code	Function name
0	FW	forward	FW	Forward
1	RV	reverse	RV	Reverse
2	CF1	multi-step speed setting binary 1	CF1	Multi-step speed setting binary 1
3	CF2	Multi-step speed setting binary 2	CF2	Multi-step speed setting binary 2
4	CF3	multi-step speed setting binary 3	CF3	Multi-step speed setting binary 3
5	CF4	multi-step speed setting binary 4	CF4	Multi-step speed setting binary 4
6	JG	jogging	JG	Jogging
7	DB	external DC injection braking	DB	External DC injection braking
8	SET	2nd control	SET	2nd control
9	2CH	2-step acceleration/deceleration	2CH	2-step acceleration/deceleration
11	FRS	free-run stop	FRS	Free-run stop
12	EXT	external trip	EXT	External trip
13	USP	USP function	UPS	Power recovery restart prevention function
14	-	-	CS	Commercial switching
15	SFT	soft lock	SFT	Soft lock
16	AT	analog input switching	AT	Analog input switching
18	RS	reset	RS	Reset
19	PTC	thermistor input	TH	PTC thermistor thermal protection
20	STA	3-wire start	STA	3-wire start
21	STP	3-wire stop	STP	3-wire stop
22	F/R	3-wire forward/reverse	F/R	3-wire forward/reverse
23	PID	PID enabled/disabled	PID	PID disabled
24	PIDC	PID integral reset	PIDC	PID integral reset
27	UP	UP/DWN function accelerated	UP	Remote operation accelerated
28	DWN	UP/DWN function decelerated	DWN	Remote operation decelerated
29	UDC	UP/DWN function data clear	UDC	Remote operation data clear
31	OPE	forced operator	OPE	Forced operator function
50	ADD	frequency addition	ADD	Set frequency A145 addition

51	F-TM	forced terminal block	F-TM	Forced terminal block
52	RDY	ready function	ATR	Torque command input permission
53	SP-SET	special 2nd function	KHC	Integrated power clear
64	EMR	emergency shutoff	-	-
255	No function	-	no	No allocation

6.3. The difference of multi-function Output Settings

There are some difference of multi-function Output Settings between 3G3JX and 3G3MX2-V1. Before setting, to refer the following table. Refer to related product user's manuals.

Data No.	3G3JX		3G3MX2-V1	
	Code	Function name	Code	Function name
0	RUN	signal during RUN	RUN	Signal during RUN
1	FA1	constant speed arrival signal	FA1	Constant speed arrival signal
2	FA2	over set frequency arrival signal	FA2	Set frequency exceeded signal
3	OL	overload warning	OL	Overload warning
4	OD	excessive PID deviation	OD	Excessive PID deviation
5	AL	alarm output	AL	Alarm signal
6	Dc	disconnection detection	FA3	Set-frequency only signal
7	FBV	PID FB status output	OTQ	Overtorque/Undertorque signal
8	NDc	network error	-	-
9	LOG	logic operation output	UV	Signal during undervoltage
10	ODc	Do not use.	TRQ	Torque limit
43	LOC	light load detection signal	LOC	Low current signal

7. Modbus Communication Data Correspondence List

There are some difference of Modbus Communication Coil Number and Register Number between 3G3JX and 3G3MX2-V1. Adjust the program of the host controller after referring to the table below and check the operation. In addition, be sure to refer to the user's manuals for each inverter.

7.1. Coil Number

Item	R/W	Description	3G3JX	3G3MX		
			Coil No.	Coil No.	Modbus coil spec. No.	
RUN command	R/W	1: Run 0: Stop (Enabled when A002 = 03)	0001h	0001h	0000h	
Rotation direction command		1: Reverse 0: Forward (Enabled when A002 = 03)	0002h	0002h	0001h	
External Trip (EXT)		1: Trip	0003h	0003h	0002h	
Trip reset (RS)		1: Reset	0004h	0004h	0003h	
Multi-function Input 1		1 : ON 0 : OFF		0007h	0007h	0006h
Multi-function Input 2				0008h	0008h	0007h
Multi-function Input 3				0009h	0009h	0008h
Multi-function Input 4				000Ah	000Ah	0009h
Multi-function Input 5			000Bh	000Bh	000Ah	
Operation status	R	1: Run 0: Stop (Interlocked with d003)	000Eh	000Fh	000Eh	
RUN direction		1: Reverse 0: Forward (Interlocked with d003)	000Fh	0010h	000Fh	
Inverter ready		1: Ready 0: Not ready	0010h	0011h	0010h	
AL (Alarm signal)		1: ON 0: OFF	0014h	0018h	0017h	
OD (Excessive PID deviation)		1 : ON 0 : OFF		0015h	0017h	0016h
OL (Overload warning)				0016h	0016h	0015h
FA2 (Set frequency exceeded signal)				0017h	0015h	0014h
FA1 (Constant speed arrival signal)				0018h	0014h	0013h
RUN (During RUN)				0019h	0013h	0012h
During data write		1: Writing 0: Normal	001Ah	0049h	0048h	
CRC error		1: Error 0: No error		001Bh	004Ah	0049h
Overrun error				001Ch	004Bh	004Ah
Framing error				001Dh	004Ch	004Bh
Parity error			001Eh	004Dh	004Ch	
Checksum error			001Fh	004Eh	004Dh	

7.2. Register Number

In 3G3MX2-V1, (Register address) = (Register number) - 1。

Function name	3G3JX				3G3MX2-V1							
	Register No.	Parameter No.	Monitor or setting data	Data resolution	Register No.	Parameter No.	Monitor or setting data	Data resolution				
Frequency reference (Enable when A001 = 03)	0002h	-	0 ~ 4000	0.1[Hz]	0001h 0002h	F001(HIGH) F001(LOW)	0 to Maximum frequency	0.01[Hz]				
Inverter status	0003h	-	00: Default 02: Stop 03: Run 04: Free-run stop (FRS) 05: Jogging 06: DC injection braking 07: Retry 08: Trip 09: Undervoltage	-	0003h	-	0: Initial status 2: Stop 3: Run 4: Free-run stop 5: Jogging 6: DC injection braking 8: Trip 9: During UV	-				
PID feedback (Enable when A076 = 02)	0005h	-	0 ~ 1000	0.1[%]	0006h	-	0~10000	0.01[%]				
Output frequency monitor	1002h	d001	0 ~ 4000	0.1[Hz]	1001h 1002h	d001(HIGH) d001(LOW)	0~40000 (In the high-frequency mode : ~58000)	0.01[Hz]				
Output current monitor	1003h	d002	0 ~ 2000	0.1[%]	1003h	d002	0~65530	0.01[A]				
Rotation direction monitor	1004h	d003	00: Stop 01: Forward 02: Reverse	-	1004h	d003	0: Stop 1: Forward 2: Reverse	-				
PID feedback value monitor (A075 PID scale)	1005h 1006h	d004(MSB) d004(LSB)	0 ~ 999900	0.01[%]	1005h 1006h	d004(HIGH) d004(LOW)	0~100000	0.1				
Multi-function input monitor	1007h	d005	0 to 63 Multi-function input status, Bit 0 = [1] to Bit 4 = [5]	-	1007h	d005	2 ⁰ : Terminal S1 ~2 ⁵ : Terminal S7/EB	ビット				
Multi-function output monitor	1008h	d006	0 to 7 Multi-function output status, Bit 0 = [P1] Bit 1 = Not used. Bit 2 = [MA]	-	1008h	d006	2 ⁰ : Terminal P1 ~2 ¹ : Terminal P2 2 ⁵ : Relay output terminal MA	ビット				
Output frequency monitor (after conversion)	1009h 100Ah	d007(MSB) d007(LSB)	0 ~ 3996000	0.01	1009h 100Ah	d007(HIGH) d007(LOW)	0~3999600 (In the high-frequency mode : ~5799420)	0.01				
Output voltage monitor	100Ch	d013	0 ~ 20000	0.01[%]	1011h	d013	0~6000	0.1[V]				
Total RUN time	100Eh 100Fh	d016(MSB) d016(LSB)	0 ~ 999999	1[h]	1015h 1016h	d016(HIGH) d016(LOW)	0~999000	1[h]				
Power ON time monitor	1010h 1011h	d017(MSB) d017(LSB)	0 ~ 999999	1[h]	1017h 1018h	d017(HIGH) d017(LOW)	0~999000	1[h]				
Fin temperature monitor	116Ah	d018	0 ~ 2000	0.1[°C]	1019h	d018	-200~+1500	0.1[°C]				
Fault frequency monitor	0011h	d080	0 ~ 65535	-	0011h	d080	0~65535	1 [回]				
DC voltage monitor	116Ch	d102	0 ~ 9999	0.1[V]	1026h	d102	0~10000	0.1[V]				
Electronic thermal monitor	116Dh	d104	0 ~ 1000	0.1[%]	1028h	d104	0~1000	0.1[%]				
Fault monitor 1	0012h	d081	Trip monitor 1: Factor code	-	0012h 0013h	d081	Fault Monitor 1 Fault	-				
	0014h		Trip monitor 1: Frequency	0.1[Hz]	0014h 0015h		Fault Monitor 1 Inverter 0~40000(LOW)	0.01[Hz]				
	0016h		Trip monitor 1: Current	0.1[A]	0016h		0~58000(HIGH)	0.01[A]				
	0017h		Trip monitor 1: Voltage	1[V]	0017h		DC Voltage	0.1[V]				
	0018h		Trip monitor 1: Run time (MSB)	1[h]	0018h		Total RUN Time (HIGH)	1[h]				
	0019h		Trip monitor 1: Run time (LSB)		0019h		Total RUN Time (LOW)					
	001Ah		Trip monitor 1: ON time (MSB)	1[h]	001Ah		Total Power ON Time (HIGH)	1[h]				
	001Bh		Trip monitor 1: ON time (LSB)		001Bh		Total Power ON Time (LOW)					
Fault monitor 2	001Ch	d082	Trip monitor 2: Factor code	-	001Ch 001Dh	d082	Fault Monitor 1 Fault	-				
	001Eh		Trip monitor 2: Frequency	0.1[Hz]	001Eh 001Fh		Fault Monitor 1 Inverter Status 0~40000(LOW)	0.01[Hz]				
	0020h		Trip monitor 2: Current	0.1[A]	0020h		0~58000(HIGH)	0.01[A]				
	0021h		Trip monitor 2: Voltage	1[V]	0021h		Output Current	0.1[V]				
	0022h		Trip monitor 2: Run time (MSB)	1[h]	0022h		DC Voltage	1[h]				
	0023h		Trip monitor 2: Run time (LSB)		0023h		Total RUN Time (HIGH)					
	0024h		Trip monitor 2: ON time (MSB)	1[h]	0024h		Total RUN Time (LOW)	1[h]				
	0025h		Trip monitor 2: ON time (LSB)		0025h		Total Power ON Time (HIGH)					
Fault monitor 3	0026h	d083	Trip monitor 3: Factor code	-	0026h 0027h	d083	Fault Monitor 1 Fault	-				
	0028h		Trip monitor 3: Frequency	0.1[Hz]	0028h 0029h		Fault Monitor 1 Inverter 0~40000(LOW)	0.01[Hz]				
	002Ah		Trip monitor 3: Current	0.1[A]	002Ah		0~58000(HIGH)	0.01[A]				
	002Bh		Trip monitor 3: Voltage	1[V]	002Bh		Output Current	0.1[V]				
	002Ch		Trip monitor 3: Run time (MSB)	1[h]	002Ch		DC Voltage	1[h]				
	002Dh		Trip monitor 3: Run time (LSB)		002Dh		Total RUN Time (HIGH)					
	002Eh		Trip monitor 3: ON time (MSB)	1[h]	002Eh		Total RUN Time (LOW)	1[h]				
	002Fh		Trip monitor 3: ON time (LSB)		002Fh		Total Power ON Time (HIGH)					
Acceleration time 1	1014h 1015h	F002(MSB) F002(LSB)	1 to 300000 The second decimal place is ignored when the value is over 10000 (100.0 seconds).	0.01[s]	1103h 1104h	F002(HIGH) F002(LOW)	0~360000	0.01[s]				
2nd acceleration time 1	1501h 1502h	F202(MSB) F202(LSB)			2103h 2104h	F202(HIGH) F202(LOW)						
Deceleration time 1	1016h 1017h	F003(MSB) F003(LSB)			1105h 1106h	F003(HIGH) F003(LOW)						
2nd deceleration time 1	1503h 1504h	F203(MSB) F203(LSB)			2105h 2106h	F203(HIGH) F203(LOW)						
Operator rotation direction selection	1018h	F004			0: Forward 1: Reverse	-			1107h	F004	00: Forward 01: Reverse	-

Frequency reference selection	1019h	A001	00: Digital Operator (volume) 01: Terminal 02: Digital Operator (F001) 03: ModBus communication 10: Frequency operation result	-	1201h	A001	00: Volume 01: Control circuit terminal block (Analog input) 02: Digital Operator 03: Modbus communication 04: Option 06: Pulse train frequency 07: DriveProgramming 10: Operation function output	-
RUN command selection	101Ah	A002	01: Terminal 02: Digital Operator 03: ModBus communication	-	1202h	A002	01: Control circuit terminal block (DriveProgramming) 02: Digital Operator 03: Modbus communication 04: Option	-
Base frequency	101Bh	A003	30. to maximum frequency A004	1[Hz]	1203h	A003	300 to 1st Maximum Frequency	0.1[Hz]
2nd base frequency	150Ch	A203	30. to maximum frequency A204		2203h	A203	300 to 2nd Maximum Frequency	
Maximum frequency	101Ch	A004	30 ~ 400	1[Hz]	1204h	A004	1st Base Frequency to 4000 (In the high-frequency mode : ~5800)	0.1[Hz]
2nd maximum frequency	150Dh	A204			1st Base Frequency to 4000 (In the high-frequency mode : ~5800)			
FV/FI selection	101Dh	A005	02: Switches between FV/VR via terminal AT 03: Switches between FI/VR via terminal AT 04: Terminal FV 05: Terminal FI	-	1205h	A005	00: Switch between FV and FI 02: Switch between FV and volume 03: Switch between FI and volume	-
FV start frequency	1020h	A011	0 ~ 4000	0.1[Hz]	120Bh	A011(HIGH)	0~4000 (In the high-frequency mode : ~58000)	0.01[Hz]
FV end frequency	1022h	A012			120Ch	A011(LOW)		
FV start ratio	1023h	A013			120Dh	A012(HIGH)		
FV end ratio	1024h	A014			120Eh	A012(LOW)		
FV start selection	1025h	A015	00: Start frequency A011 01: 0 Hz	-	1210h	A013 A014	0~100	1[%]
FV, FI sampling	1026h	A016	1 ~ 17	-	1211h	A015	00: FV Start Frequency (A011) 01: 0 Hz	-
Multi-step speed reference 0	1029h	A020	0.0/Starting frequency to 4000	0.1[Hz]	1216h	A020(HIGH)	0 Starting Frequency to 1st Maximum Frequency 0 Starting Frequency to 2nd Maximum Frequency 0 Starting frequency to Maximum frequency	0.01[Hz]
					1217h	A020(LOW)		
					2216h	A220(HIGH)		
					2217h	A220(LOW)		
					1218h	A021(HIGH)		
					1219h	A021(LOW)		
					121Ah	A022(HIGH)		
					121Bh	A022(LOW)		
					121Ch	A023(HIGH)		
					121Dh	A023(LOW)		
					121Eh	A024(HIGH)		
					121Fh	A024(LOW)		
					1220h	A025(HIGH)		
					1221h	A025(LOW)		
					1222h	A026(HIGH)		
					1223h	A026(LOW)		
1224h	A027(HIGH)							
1225h	A027(LOW)							
1226h	A028(HIGH)							
1227h	A028(LOW)							
1228h	A029(HIGH)							
1229h	A029(LOW)							
122Ah	A030(HIGH)							
122Bh	A030(LOW)							
122Ch	A031(HIGH)							
122Dh	A031(LOW)							
122Eh	A032(HIGH)							
122Fh	A032(LOW)							
1230h	A033(HIGH)							
1231h	A033(LOW)							
1232h	A034(HIGH)							
1233h	A034(LOW)							
1234h	A035(HIGH)							
1235h	A035(LOW)							
Jogging frequency	1048h	A038	0 ~ 999	0.01[Hz]	1238h	A038	Starting Frequency to 999 (In the high-frequency mode : 10000)	0.01[Hz]
Jogging stop selection	1049h	A039	00: Free-run stop 01: Deceleration stop 02: DC injection braking stop	-	1239h	A039	00: Free-running on jogging stop/ Disabled during operation 01: Deceleration stop on jogging stop/ Disabled during operation 02: DC injection braking on jogging stop/ Disabled during operation 03: Free-running on jogging stop/ Enabled during operation 04: Deceleration stop on jogging stop/ Enabled during operation 05: DC injection braking on jogging stop/ Enabled during operation	-
Torque boost selection	104Ah	A041	00: Manual torque boost only	-	123Bh	A041	00: Manual torque boost	-
2nd torque boost selection	1510h	A241	01: Simple torque boost	-	223Bh	A241	01: Automatic torque boost	-
Manual torque boost voltage	104Bh	A042	0 ~ 200	0.1[%]	123Ch	A042	0~200	0.1[%]
2nd manual torque boost	1511h	A242			223Ch	A242		
Manual torque boost	104Ch	A043	0 ~ 500	0.1[%]	123Dh	A043	0~500	0.1[%]
2nd manual torque boost	1512h	A243			223Dh	A243		
V/f characteristics selection	104Dh	A044	00: VC	-	123Eh	A044	00: Constant torque characteristics	-
2nd V/f characteristics selection	1513h	A244	01: 1.7th power of VP 06: Special VP	-	223Eh	A244	01: Reduced torque characteristics 02: Free V/f setting	-

Output voltage gain	104Eh	A045	20 ~ 100	1[%]	123Fh	A045	20~100	1[%]				
2nd output voltage gain	1514h	A245			223Fh	A245						
DC injection braking selection	1051h	A051	00: Disabled 01: Enabled during stop 02: Output frequency<A052 DB	-	1245h	A051	00: Disabled 01: Enabled 02: Enabled (Operates only at set frequency)	-				
DC injection braking frequency	1052h	A052	0 ~ 600	0.1[Hz]	1246h	A052	0~6000	0.01[Hz]				
DC injection braking delay time	1053h	A053	0 ~ 50	0.1[s]	1247h	A053	0~50	0.1[s]				
DC injection braking power	1054h	A054	0 ~ 100	1[%]	1248h	A054	0~100 (70)	1[%]				
DC injection braking time	1055h	A055	0 ~ 600	0.1[s]	1249h	A055	0~600	0.1[s]				
DC injection braking method selection	1056h	A056	00: Edge operation 01: Level operation	-	124Ah	A056	00: Edge operation 01: Level operation	-				
Frequency upper limit	105Ah	A061	0.0/Frequency lower limit : A062 x 10 to Maximum frequency : A004 x 10	0.1[Hz]	124Fh	A061(HIGH)	0	0.01[Hz]				
2nd frequency upper limit	1517h	A261	0.0/2nd frequency lower limit : A262 x 10 to 2nd max. frequency : A204 x 10		1250h	A061(LOW)	1st Frequency Lower Limit to 1st Maximum Frequency					
Frequency lower limit	105Bh	A062	0.0/Starting frequency : b082 x 10 to Frequency upper limit: A061 x 10		224Fh	A261(HIGH)	0					
2nd frequency lower limit	1518h	A262	0.0/Starting frequency : b082 x 10 to 2nd frequency upper limit: A261x10		2250h	A261(LOW)	2nd Frequency Lower Limit to 2nd Maximum Frequency					
Jump frequency 1	105Dh	A063	0 ~ 4000	0.1[Hz]	1251h	A062(HIGH)	0	0.01[Hz]				
Jump frequency 2	1060h	A065			1252h	A062(LOW)	Starting Frequency to 1st Maximum Frequency					
Jump frequency 3	1063h	A067			1251h	A262(HIGH)	0					
Jump frequency width 1	105Eh	A064			1252h	A262(LOW)	Starting Frequency to 2nd Frequency Upper Limit					
Jump frequency width 2	1061h	A066	0 ~ 100	0.1[Hz]	1253h	A063(HIGH)	0~40000 (In the high-frequency mode : ~58000)	0.01[Hz]				
Jump frequency width 3	1064h	A068			1254h	A063(LOW)						
PID selection	1068h	A071			00: Disabled 01: Enabled	-			1256h	A065(HIGH)		
PID P gain	1069h	A072	2 ~ 50	0.1	1257h	A065(LOW)						
PID I gain	106Ah	A073	0 ~ 1500	0.1[s]	1259h	A067(HIGH)						
PID D gain	106Bh	A074	0 ~ 1000	0.1[s]	125Ah	A067(LOW)						
PID scale	106Ch	A075	1 ~ 9999	0.01	1255h	A064	0~1000 (In the high-frequency mode : ~10000)	0.01[Hz]				
					1258h	A066						
					125Bh	A068						
PID feedback selection	106Dh	A076	00: Feedback (FI) 01: Feedback (FV) 02: External communication 10: Operation function output	-	125Fh	A071	00: Disabled 01: Enabled 02: Enabled (Reverse output enabled)	-				
Reverse PID function	106Eh	A077	00: OFF (Deviation = Target value - Feedback value) 01: ON (Deviation = Feedback value - Target value)	-	1260h	A072	0~2500	0.01				
PID output limit function	106Fh	A078	0 ~ 1000	0.1[%]	1261h	A073	0~36000	0.1[s]				
AVR selection	1070h	A081	00: Always ON 01: Always OFF 02: OFF during deceleration	-	1262h	A074	0~10000	0.01[s]				
AVR voltage selection	1071h	A082	200-V class 0: 200/ 1: 215/ 2: 220/ 3: 230/ 4: 240 400-V class 0: 380/ 1: 400/ 2: 415/ 3: 440/ 4: 460/ 5: 480	-	1263h	A075	1~9999	0.01				
RUN mode selection	1072h	A085	00: Normal operation 01: Energy-saving operation	-	1266h	A078	0~1000	0.1[%]				
Energy-saving response/	1073h	A086	0 ~ 1000	0.1[%]	126Eh	A086	0~1000	0.1[%]				
Acceleration time 2	1074h	A092(MSB)	1 to 300000 The second decimal place is ignored when the value is over 10000 (100.0 seconds).	0.01 [s]	1274h	A092(HIGH)	0~360000	0.01[s]				
2nd acceleration time 2	1075h	A092(LSB)			1275h	A092(LOW)						
Deceleration time 2	1519h	A292(MSB)			1276h	A093(HIGH)						
	151Ah	A292(LSB)			1277h	A093(LOW)						
2nd deceleration time 2	1076h	A093(MSB)			1271h	A293(HIGH)						
	1077h	A093(LSB)			1272h	A293(LOW)						
2-step acceleration/ deceleration selection	151Bh	A293(MSB)										
	151Ch	A293(LSB)										
2-step acceleration/ deceleration selection	1078h	A094			00: Switched via terminal 2CH 01: Switched by setting	-			1278h	A094	00: Switch via 2CH terminal (multi-function input: 09) 01: Switch by setting(A095/ A295/ A096/ A296)	-
2-step acceleration frequency	107Ah	A095			0 ~ 4000	0.1[Hz]			1279h	A095(HIGH)	0~40000 (In the high-frequency mode : ~58000)	0.01[Hz]
2nd 2-step acceleration frequency	151Fh	A295	127Ah	A095(LOW)								
2-step deceleration frequency	107Ch	A096	1274h	A295(HIGH)								
	1521h	A296	1275h	A295(LOW)								
Acceleration pattern selection	107Dh	A097	127Bh	A096(HIGH)			00: Line 01: S-shape curve	127Dh	A097	00: Line 01: S-shape curve 02: U-shape curve 03: Inverted U-shape curve 04: EL-S-shape curve		
	Deceleration pattern selection	107Eh	A098	127Ch								
FI start frequency	1080h	A101	0 ~ 4000	0.1[Hz]	1276h	A296(HIGH)	0~40000 (In the high-frequency mode : ~58000)	0.01[Hz]				
FI end frequency	1082h	A102			1277h	A296(LOW)						
	1083h	A103										
FI start ratio	1083h	A103			0 ~ 100	1			1281h	A101(HIGH)	0~100	1[%]
FI end ratio	1084h	A104			1282h	A101(LOW)						
					1283h	A102(HIGH)						
					1284h	A102(LOW)						
					1285h	A103						
					1286h	A104						

FI start selection	1085h	A105	00: Start frequency A101 01: 0 Hz	-	1287h	A105	00: FI Start Frequency (A101) 01: 0 Hz	-
Operation frequency input A setting	108Eh	A141	00: Digital Operator (F001) 01: Digital Operator (volume) 02: Input FV 03: Input FI	-	12AFh	A141	00: Digital Operator (A020/A220) 01: Volume 02: Voltage (FV) input 03: Current (FI) input	-
Operation frequency input B setting	108Fh	A142	04: RS485 communications	-	12B0h	A142	04: Modbus communication 05: Option 07: Pulse train frequency	-
Operator selection	1090h	A143	00: Addition (A + B) 01: Subtraction (A - B) 02: Multiplication (A × B)	-	12B1h	A143	00: Addition (A141 + A142) 01: Subtraction (A141 - A142) 02: Multiplication (A141 × A142)	-
Frequency addition amount	1091h	A145	0 ~ 4000	0.1[Hz]	12B3h 12B4h	A145(HIGH) A145(LOW)	0~40000 (In the high-frequency mode : ~58000)	0.01[Hz]
Frequency addition direction	1093h	A146	00: Adds the A145 value to the output	-	12B5h	A146	00: Frequency reference + A145 01: Frequency reference - A145	-
VR start frequency	1095h	A151	0 ~ 4000	0.1[Hz]	12C6h 12C7h	A161(HIGH) A161(LOW)	0~40000 (In the high-frequency mode : ~58000)	0.01[Hz]
VR end frequency	1097h	A152	0 ~ 4000	0.1[Hz]	12C8h 12C9h	A162(HIGH) A162(LOW)	0~40000 (In the high-frequency mode : ~58000)	0.01[Hz]
VR start ratio	1098h	A153	0 ~ 100	1[%]	12CAh	A163	0 to VR End Ratio	1[%]
VR end ratio	1099h	A154	0 ~ 100	1[%]	12CBh	A164	VR Start Ratio to 100	1[%]
VR start selection	109Ah	A155	0, 1	-	12CCh	A165	00: VR Start Frequency (A161) 01: 0 Hz	-
Retry selection	10A5h	b001	00: Alarm 01: 0 Hz start 02: Frequency matching restart 03: Trip after frequency matching deceleration stop	-	1301h	b001	00: Trip 01: 0-Hz restart 02: Frequency matching restart 03: Trip after frequency matching deceleration stop 04: Frequency pull-in restart	-
Allowable momentary power	10A6h	b002	3 ~ 250	0.1[s]	1302h	b002	3~250	0.1[s]
Retry wait time	10A7h	b003	3 ~ 1000	0.1[s]	1303h	b003	3~1000	0.1[s]
Momentary power interruption/undervoltage trip during stop selection	10A8h	b004	00: Disabled 01: Enabled	-	1304h	b004	00: Disabled 01: Enabled 02: Disabled during stop and deceleration stop by turning off the RUN command	-
Momentary power interruption retry time	10A9h	b005	00: 16 times 01: No limit	-	1305h	b005	00: 16 times 01: No limit	-
Starting frequency at frequency pull-in restart	1170h	b011	00: Frequency at interruption 01: Max. frequency 02: Set frequency	-	131Fh	b030	00: Frequency at interruption 01: Maximum frequency 02: Set frequency (Frequency reference)	-
Electronic thermal level	10ADh	b012	2000 to 10000	0.01[%]	130Dh	b012	200~1000	0.1[%]
2nd electronic thermal level	1527h	b212	Set the rated current to 10000	-	230Ch	b212	200~1000	0.1[%]
Electronic thermal characteristics selection	10AEh	b013	00: Reduced torque characteristics 1 01: Constant torque characteristics	-	130Eh	b013	00: Reduced torque characteristics 01: Constant torque characteristics	-
2nd electronic thermal characteristics selection	1528h	b213	02: Reduced torque characteristics 2	-	230Dh	b213	02: Free setting	-
Overload limit selection	10B5h	b021	00: Disabled 01: Enabled in acceleration/constant	-	1316h 2316h	b021 b221	00: Disabled 01: Enabled during	-
2nd overload limit selection	1529h	b221	00: Disabled 01: Enabled in acceleration/constant	-	1317h 2317h	b022 b222	200~2000	0.1[%]
Overload limit level	10B6h	b022	00: Disabled 01: Enabled in acceleration/constant	0.01[%]	1318h 2318h	b023 b223	1~30000	0.1[s]
2nd overload limit level	152Ah	b222	1 ~ 300	0.1[s]	1319h 2319h	b024 b224	1~30000	0.1[s]
Overload limit parameter	10B7h	b023	1 ~ 30000	0.1[s]	131Eh	b029	1~30000	0.1[s]
2nd overload limit parameter	152Bh	b223	1 ~ 30000	0.1[s]	131Fh	b030	1~30000	0.1[s]
Deceleration rate constant	1171h	b029	200 ~ 20000	0.01[%]	131Dh	b028	200~2000	0.1[%]
Frequency pull-in restart	1172h	b030	00: Data other than b031 cannot be changed when terminal SFT is ON. 01: Data other than b031 and the specified frequency parameter cannot be changed when terminal SFT is ON. 02: Data other than b031 cannot be changed. 03: Data other than b031 and the specified frequency parameter cannot be changed. 10: Data other than parameters changeable during operation cannot be changed.	-	1320h	b031	00: Data other than b031 cannot be changed when terminal SFT is ON. 01: Data other than b031 and the set frequency cannot be changed when terminal SFT is ON. 02: Data other than b031 cannot be changed. 03: Data other than b031 and set frequency cannot be changed. 10: Data can be changed during RUN.	-
Selection of non-stop function at momentary power interruption	10C9h	b050	00: Disabled 01: Enabled (Stop) 02: Enabled (Restart)	-	1334h	b050	00: Disabled 01: Enabled (Deceleration stop) 02: Enabled (Constant voltage, without recovery) 03: Enabled (Constant voltage, with recovery)	-
Starting voltage of non-stop function at momentary power interruption	10CAh	b051	0 ~ 10000	0.1[V]	1335h	b051	0~10000	0.1[V]
Stop deceleration level of non-stop function at momentary power interruption	10CBh	b052	0 ~ 10000	0.1[V]	1336h	b052	0~10000	0.1[V]
Deceleration time of nonstop function at momentary	10CCh	b053	1 ~ 30000	0.1[s]	1337h 1338h	b053(HIGH) b053(LOW)	1~360000	0.01[s]
Deceleration starting width of non-stop function at momentary power interruption	10CEh	b054	0 ~ 100	0.1[Hz]	1339h	b054	0~1000 (In the high-frequency mode : 10000)	0.01[Hz]
Overvoltage protection proportional gain during deceleration	1173h	b055	2 ~ 50	0.1	1388h	b133	0~500	0.01
Overvoltage protection integral time during deceleration	1174h	b056	0 ~ 1500	0.1[s]	1389h	b134	0~1500	0.1[s]

Starting frequency	10D1h	b082	5 ~ 99	0.1[Hz]	1355h	b082	1~999 (In the high-frequency mode : ~10000)	0.01[Hz]
Carrier frequency	10D2h	b083	20 ~ 120	0.1[kHz]	1356h	b083	20~150 (100)	0.1[kHz]
Initialization selection	10D3h	b084	00: Clears the trip monitor 01: Initializes data 02: Clears the trip monitor and initializes data	-	1357h	b084	00: Initialization disabled 01: Clearing fault monitor 02: Initialize data 03: Clear fault monitor + Initialize data 04: Clear fault monitor + Initialize data + Clear DriveProgramming	-
Initialization parameter selection	10D4h	b085	00: Fixed Do not change.	-	1358h	b085	Do not change the default 00.	-
Frequency conversion	10D5h	b086	1 ~ 999	0.1	1359h	b086	1~9999	0.01
STOP key selection	10D6h	b087	00: Enabled 01: Disabled	-	135Ah	b087	00: Enabled 01: Disabled 02: Only RESET enabled	-
Free-run stop selection	10D7h	b088	00: 0 Hz start 01: Frequency pull-in restart	-	135Bh	b088	00: 0-Hz restart 01: Frequency matching restart 02: Frequency pull-in restart	-
Stop selection	10DAh	b091	00: Deceleration→Stop 01: Free-run stop	-	135Eh	b091	00: Deceleration stop 01: Free-run stop	-
Cooling fan control	10DBh	b092	00: Always ON 01: ON during RUN 02: Depends on the fin temperature	-	135Fh	b092	00: Always enabled 01: Enabled only during operation (including 5 minutes after power on/stop) 02: Dependent on cooling fin temperature	-
Overvoltage protection function selection during deceleration	1176h	b133	00: Disabled 01: Enabled	-	1385h	b130	00: Disabled 01: DC voltage kept constant 02: Acceleration enabled	-
Overvoltage protection level setting during deceleration	1177h	b134	200-V class: 330. to 395. 400-V class: 660. to 790.	1[V]	1386h	b131	200-V class: 330 to 395 400-V class: 660 to 790	1[V]
Overcurrent suppression function	10F7h	b140	00: Disabled 01: Enabled	-	131Ch	b027	00: Disabled 01: Enabled 02: Enabled (at reduced voltage startup)	-
Automatic carrier reduction	10F8h	b150	00: Disabled 01: Enabled	-	135Ch	b089	00: Disabled 01: Enabled (dependent on current) 02: Enabled (dependent on cooling fin temperature)	-

Multi-function input 1 selection	1103h	C001	00: FW 01: RV 02: CF1 03: CF2 04:CF3 05: CF4 06: JG 07: DB 08: SET 09: 2CH 11: FRS 12: EXT 13: USP 15: SFT 16: AT 18: RS 19: PTC terminal 5 only 20: STA 2+1: STP 22: F/R 23: PID 24: PIDC 27: UP 28: DWN 29: UDC 31: OPE 50: ADD 51: F-TM 52: RDY 53: SP-SET 64: EMR(automatically allocated to terminal 3 if enabled) 255: NO		1401h	C001	00: FW (Forward) 01: RV (Reverse) 02: CF1 (Multi-step speed setting binary 1) 03: CF2 (Multi-step speed setting binary 2) 04: CF3 (Multi-step speed setting binary 3) 05: CF4 (Multi-step speed setting binary 4) 06: JG (Jogging) 07: DB (External DC injection braking) 08: SET (2nd control) 09: 2CH (2-step acceleration/deceleration) 11: FRS (Free-run stop) 12: EXT (External trip) 13: USP (Power recovery restart prevention function) 14: CS (Commercial switch) 15: SFT (Soft lock) 16: AT (Analog input switching) 18: RS (reset) 19: TH (PTC thermistor thermal protection) <C005 only> 20: STA (3-wire start) 21: STP (3-wire stop) 22: F/R (3-wire forward/reverse) 23: PID (PID disabled) 24: PIDC (PID integral reset) 27: UP (Remote operation accelerated) 28: DWN (Remote operation decelerated) 29: UDC (Remote operation data clear) 31: OPE (Forced operator function) 32: SF1 (Multi-step speed setting bit 1) 33: SF2 (Multi-step speed setting bit 2) 34: SF3 (Multi-step speed setting bit 3) 35: SF4 (Multi-step speed setting bit 4) 36: SF5 (Multi-step speed setting bit 5) 37: SF6 (Multi-step speed setting bit 6) 38: SF7 (Multi-step speed setting bit 7) 39: OLR (Overload limit switching) 40: TL (Torque limit enabled) 41: TRQ1 (Torque limit switching 1) 42: TRQ2 (Torque limit switching 2) 44: BOK (Brake confirmation) 46: LAC (LAD cancel) 47: PCLR (Current position clear) 50: ADD (Set frequency A145 addition) 51: F-TM (Forced terminal block) 52: ATR (Torque reference input permission) 53: KHC (Integrated power clear) 56: MI1 (General-purpose input 1) 57: MI2 (General-purpose input 2) 58: MI3 (General-purpose input 3)	
2nd multi-function input 1 selection	1532h	C201						
Multi-function input 2 selection	1104h	C002			1402h	C002		
2nd multi-function input 2 selection	1533h	C202						
Multi-function input 3 selection	1105h	C003			1403h	C003		
2nd multi-function input 3 selection	1534h	C203						
Multi-function input 4 selection	1106h	C004			1404h	C004		
2nd multi-function input 4 selection	1535h	C204						
Multi-function input 5 selection	1107h	C005			1405h	C005		
2nd multi-function input 5 selection	1536h	C205						
Multi-function input 1	110Bh	C011	00 : NO 01 : NC		140Bh	C011	00: NO (NO contact) 01: NC (NC contact)	
Multi-function input 2	110Ch	C012			140Ch	C012		
Multi-function input 3	110Dh	C013			140Dh	C013		
Multi-function input 4	110Eh	C014			140Eh	C014		
Multi-function input 5	110Fh	C015			140Fh	C015		

Multi-function output terminal P1 selection	1114h	C021	00: RUN 01: FA1 02: FA2 03: OL 04: OD 05: AL 06: Dc 07: FBV 08: NDc 09: LOG 10: ODC(Do not use.) 43: LOC	-	1415h	C021	00: RUN (During RUN) 01: FA1 (Constant speed arrival signal) 02: FA2 (Set frequency exceeded signal) 03: OL (Overload warning) 04: OD (Excessive PID deviation) 05: AL (Alarm signal) 06: FA3 (Set-frequency only signal) 07: OTQ (Overtorque/Undertorque signal) 09: UV (Signal during undervoltage) 10: TRQ (Torque limit) 11: RNT (RUN time over) 12: ONT (Power ON time over) 13: THM (Electronic thermal warning) 19: BRK (Brake release) 20: BER (Brake error) 21: ZS (0-Hz detection signal) 22: DSE (Excessive speed deviation) 23: POK (Position ready) 24: FA4 (Set frequency exceeded signal 2) 25: FA5 (Set-frequency only signal 2) 26: OL2 (Overload warning 2) 27: FVDC (Analog FV disconnection detection) 28: FIDc (Analog FI disconnection detection) 31: FBV (PID feedback comparison) 32: NDc (Communications disconnection detection) 33: LOG1 (Logic operation output 1) 34: LOG2 (Logic operation output 2) 35: LOG3 (Logic operation output 3) 39: WAC (Capacitor life warning) 40: WAF (Cooling fan life warning) 41: FR (Starting contact signal) 42: OHF (Cooling fin overheat warning) 43: LOC (Low current signal) 44: MO1 (General-purpose output 1) 45: MO2 (General-purpose output 2) 46: MO3 (General-purpose output 3) 50: IRDY (Operation ready) 51: FWR (Forward run) 52: RVR (Reverse run) 53: MJA (Fatal fault signal) 54: WCFV (Window comparator FV) 55: WCFI (Window comparator FI) 58: FREF (Frequency reference source) 59: REF (RUN command source) 60: SETM (Motor 2 selection) 62: EDM (Safety device monitor signal) 63: OPO (Option) 255: no (No allocation)	-
Relay output (MA, MB) function selection	1119h	C026		-	141Ah	C026	00: Output frequency 01: Output current 02: Output torque 04: Output voltage 05: Input power 06: Electronic thermal load rate 07: LAD frequency 10: Cooling fin temperature 11: Output torque (signed) 13: DriveProgramming (YA(1)) 16: Option (No applicable Option)	-
AM selection	111Bh	C028	00: F (Output frequency) 01: A (Output current)	-	141Ch	C028		-
Multi-function output	111Dh	C031	00 : NO	-	141Fh	C031	00: NO (NO contact)	-
Relay output (MA, MB)	1122h	C036	01 : NC	-	1424h	C036	01: NC (NC contact)	-
Light load signal output mode	1178h	C038	00: Enabled during acceleration/ deceleration/ constant speed 01: Enabled only during constant speed	-	1426h	C038	00: During acceleration/ deceleration and constant speed 01: Only during constant speed	-
Light load detection level	1179h	C039	0 to 20000	0.01[%]	1427h	C039	0~2000	0.1[%]
Overload warning level	1124h	C041	0 to 20000		1429h	C041		
2nd overload warning level	153Ah	C241	Set to 10000 at rated current	0.01[%]	2429h	C241	0~2000	0.1[%]
Arrival frequency during acceleration	1126h	C042			142Ah	C042(HIGH)		
Arrival frequency during deceleration	1128h	C043	0 ~ 4000	0.1[Hz]	142Bh	C042(LOW)	0~40000 (In the high-frequency mode : 58000)	0.01[Hz]
PID deviation excessive	1129h	C044	0 ~ 1000	0.1[%]	142Ch	C043(HIGH)		
					142Dh	C043(LOW)		
					142Eh	C044	0~1000	0.1[%]

Communication speed selection (Baud rate selection)	1138h	C071	Do not change through ModBus communication. For setting, refer to "ModBus Setting" (4-78).	0.1[%]	144Bh	C071	03(2400bps)/ 04(4800bps)/ 05(9600bps)/ 06(19.2kbps)/ 07(38.4kbps)/ 08(57.6kbps)/ 09(76.8kbps)/ 10(115.2kbps)	-	
Communication station No.	1139h	C072			144Ch	C072	1~247		
Communication parity selection	113Bh	C074			144Eh	C074	00: No/ 01: Even/ 02: Odd		
Communication stop bit selection	113Ch	C075			144Fh	C075	1: 1 bit 2: 2 bits		
Communication error selection	113Dh	C076			1450h	C076	00: Trip 01: Trip after deceleration stop 02: Ignore 03: Free-run stop 04: Deceleration stop		
Communication error timeout	113Eh	C077			1451h	C077	0: Timeout disabled 1 to 9999		0.01[s]
Communication wait time	113Fh	C078			1452h	C078	0~1000		1[ms]
FV adjustment	1141h	C081			1455h	C081	0~2000		0.1[%]
FI adjustment	1142h	C082			1456h	C082			
UP/DWN selection	1149h	C101			00 : OFF 01 : ON	-	1469h		C101
Reset selection	114Ah	C102	00: Trip reset at power-on 01: Trip reset when the power is OFF 02: Enabled only during trip (Reset when the power is ON.) 03: Trip reset only	-	146Ah	C102	00: Trip reset at power-on 01: Trip reset at power-off 02: Enabled only during trip (Reset at power-on) 03: Trip reset only	-	
Logic operation function A input	1150h	C141	00 : RUN/01 : FA1/02 : FA2/03 : OL/04 : OD/05 : AL/06 : Dc/07 : FBV/08 : NDC/10 : ODC (使用しないでください) /43 : LOC	-	1492h	C142	Same as C021 (Except 33 (LOG1) to 35 (LOG3), 63 (OP0), and 255 (no))	-	
Logic operation function B input	1151h	C142		1493h	C143				
Logic operator selection	1152h	C143	00 : AND/01 : OR/02 : XOR	-	1494h	C144	00:AND 01:OR 02:XOR	-	
Output terminal P1 ON delay	1153h	C144	0 ~ 1000	0.1[s]	1486h	C130	0~1000	0.1[s]	
Output terminal P1 OFF	1154h	C145			1487h	C131			
Relay output ON delay	1157h	C148			1490h	C140			
Relay output OFF delay	1158h	C149			1491h	C141			
Motor capacity selection	1165h	H003	00 : 0.2/ 02 : 0.4/ 04 : 0.75/ 06 : 1.5/ 07 : 2.2/ 09 : 3.7/ 11 : 5.5/ 12 : 7.5	-	1503h	H003	00:0.1/ 01:0.2/ 02:0.4/ 03:0.55/ 04:0.75/ 05:1.1/ 06:1.5/ 07:2.2/ 08:3.0/ 09:3.7/ 10:4.0/ 11:5.5/ 12:7.5/ 13:11.0/ 14:15.0/ 15:18.5	-	
2nd motor capacity selection	1541h	H203		2503h	H203				
Motor pole number selection	1166h	H004	2/4/6/8	1[極]	1504h	H004	00:2P/ 01:4P/ 02:6P/ 03:8P 04~23:10~48Pは設定しないでください	-	
2nd motor pole number	1542h	H204			2504h	H204			
Stabilization parameter	1168h	H006	0. ~ 255.	1[%]	1507h	H006	0~255	1[%]	
2nd stabilization parameter	1544h	H206			2507h	H206			
Enter command	0900h	-	Indefinite value	-	0900h	-	1	-	

Please note that 3G3MX2-V1 does not provide the following functions:

Function name	3G3JX	
	Register No.	Parameter No.
Overload limit source selection	10BBh	b028
2nd overload limit source selection	152Ch	b228
AM adjustment	10CFh	b080
Monitor display selection	10D8h	b089
Overvoltage LAD stop function	10F5h	b130
Overvoltage LAD stop function level setting	10F6h	b131
Ready function selection	10F9h	b151
PID FB upper limit	112Eh	C052
PID FB lower limit	112Fh	C053
Operator/ModBus selection	1137h	C070
AM offset adjustment	1145h	C086

Note: Do not use this document to operate the Unit.

OMRON Corporation Industrial Automation Company

Tokyo, JAPAN

Contact: www.ia.omron.com

Regional Headquarters

OMRON EUROPE B.V.

Wegalaan 67-69, 2132 JD Hoofddorp
The Netherlands
Tel: (31)2356-81-300/Fax: (31)2356-81-388

OMRON ELECTRONICS LLC

2895 Greenspoint Parkway, Suite 200
Hoffman Estates, IL 60169 U.S.A
Tel: (1) 847-843-7900/Fax: (1) 847-843-7787

OMRON ASIA PACIFIC PTE. LTD.

No. 438A Alexandra Road # 05-05/08 (Lobby 2),
Alexandra Technopark,
Singapore 119967
Tel: (65) 6835-3011/Fax: (65) 6835-2711

OMRON (CHINA) CO., LTD.

Room 2211, Bank of China Tower,
200 Yin Cheng Zhong Road,
PuDong New Area, Shanghai, 200120, China
Tel: (86) 21-5037-2222/Fax: (86) 21-5037-2200

Authorized Distributor:

© OMRON Corporation 2019 All Rights Reserved.
In the interest of product improvement,
specifications are subject to change without notice.

Cat. No. I924-E1-01

0919 (0919)