

AC Servomotor/Servo Drives

Replace Guide

From G Series with General-purpose Pulse Train or Analog Input

to G5 Series with General-purpose Pulse Train or Analog Input

R88M-K[], R88D-KT[]

R88M-G[], R88D-GT[]



Replace
Guide

NOTE

All rights reserved. No part of this publication may be reproduced, stored in a retrieval system, or transmitted, in any form, or by any means, mechanical, photocopying, recording, or otherwise, without the prior written permission of OMRON.

No patent liability is assumed with respect to the use of the information contained herein. Moreover, because OMRON is constantly striving to improve its high-quality products, the information contained in this manual is subject to change without notice. Every precaution has been taken in the preparation of this manual. Nevertheless, OMRON assumes no responsibility for errors or omissions. Neither is any liability assumed for damages resulting from the use of the information contained in this publication.

Introduction

This Guide does not contain safety information and other details that are required for actual use. Thoroughly read and understand the manuals for all of the devices that are used in this Guide to ensure that the system is used safely. Review the entire contents of these materials, including all safety precautions, precautions for safe use, and precautions for correct use.

Intended Audience

This Guide is intended for the following personnel.

- Personnel in charge of introducing FA systems
- Personnel in charge of designing FA systems

The personnel must also have the following knowledge.

- Knowledge of electrical systems (an electrical engineer or the equivalent)
- Knowledge of AC Servomotors/Drives

Applicable Products

This Guide covers the following products.

- G-series AC Servomotors/Servo Drives with General-purpose Pulse Train or Analog Input
- G5-series AC Servomotors/Servo Drives with General-purpose Pulse Train or Analog Input

Terms and Conditions Agreement

Warranties

(a) Exclusive Warranty. Omron's exclusive warranty is that the Products will be free from defects in materials and workmanship for a period of twelve months from the date of sale by Omron (or such other period expressed in writing by Omron). Omron disclaims all other warranties, express or implied.

(b) Limitations. OMRON MAKES NO WARRANTY OR REPRESENTATION, EXPRESS OR IMPLIED, ABOUT NON-INFRINGEMENT, MERCHANTABILITY OR FITNESS FOR A PARTICULAR PURPOSE OF THE PRODUCTS. BUYER ACKNOWLEDGES THAT IT ALONE HAS DETERMINED THAT THE PRODUCTS WILL SUITABLY MEET THE REQUIREMENTS OF THEIR INTENDED USE.

Omron further disclaims all warranties and responsibility of any type for claims or expenses based on infringement by the Products or otherwise of any intellectual property right. (c) Buyer Remedy.

Omron's sole obligation hereunder shall be, at Omron's election, to (i) replace (in the form originally shipped with Buyer responsible for labor charges for removal or replacement thereof) the non-complying Product, (ii) repair the non-complying Product, or (iii) repay or credit Buyer an amount equal to the purchase price of the non-complying Product; provided that in no event shall Omron be responsible for warranty, repair, indemnity or any other claims or expenses regarding the Products unless Omron's analysis confirms that the Products were properly handled, stored, installed and maintained and not subject to contamination, abuse, misuse or inappropriate modification. Return of any Products by Buyer must be approved in writing by Omron before shipment. Omron Companies shall not be liable for the suitability or unsuitability or the results from the use of Products in combination with any electrical or electronic components, circuits, system assemblies or any other materials or substances or environments. Any advice, recommendations or information given orally or in writing, are not to be construed as an amendment or addition to the above warranty.

See <http://www.omron.com/global/> or contact your Omron representative for published information.

Limitation on Liability; Etc

OMRON COMPANIES SHALL NOT BE LIABLE FOR SPECIAL, INDIRECT, INCIDENTAL, OR CONSEQUENTIAL DAMAGES, LOSS OF PROFITS OR PRODUCTION OR COMMERCIAL LOSS IN ANY WAY CONNECTED WITH THE PRODUCTS, WHETHER SUCH CLAIM IS BASED IN CONTRACT, WARRANTY, NEGLIGENCE OR STRICT LIABILITY.

Further, in no event shall liability of Omron Companies exceed the individual price of the Product on which liability is asserted.

Suitability of Use

Omron Companies shall not be responsible for conformity with any standards, codes or regulations which apply to the combination of the Product in the Buyer's application or use of the Product. At Buyer's request, Omron will provide applicable third party certification documents identifying ratings and limitations of use which apply to the Product. This information by itself is not sufficient for a complete determination of the suitability of the Product in combination with the end product, machine, system, or other application or use. Buyer shall be solely responsible for determining appropriateness of the particular Product with respect to Buyer's application, product or system. Buyer shall take application responsibility in all cases.

NEVER USE THE PRODUCT FOR AN APPLICATION INVOLVING SERIOUS RISK TO LIFE OR PROPERTY WITHOUT ENSURING THAT THE SYSTEM AS A WHOLE HAS BEEN DESIGNED TO ADDRESS THE RISKS, AND THAT THE OMRON PRODUCT(S) IS PROPERLY RATED AND INSTALLED FOR THE INTENDED USE WITHIN THE OVERALL EQUIPMENT OR SYSTEM.

Programmable Products

Omron Companies shall not be responsible for the user's programming of a programmable Product, or any consequence thereof.

Performance Data

Data presented in Omron Company websites, catalogs and other materials is provided as a guide for the user in determining suitability and does not constitute a warranty. It may represent the result of Omron's test conditions, and the user must correlate it to actual application requirements. Actual performance is subject to the Omron's Warranty and Limitations of Liability

Change in Specifications

Product specifications and accessories may be changed at any time based on improvements and other reasons. It is our practice to change part numbers when published ratings or features are changed, or when significant construction changes are made. However, some specifications of the Product may be changed without any notice. When in doubt, special part numbers may be assigned to fix or establish key specifications for your application. Please consult with your Omron's representative at any time to confirm actual specifications of purchased Product.

Errors and Omissions

Information presented by Omron Companies has been checked and is believed to be accurate; however, no responsibility is assumed for clerical, typographical or proofreading errors or omissions.

Precautions

- When building a system, check the specifications for all devices and equipment that will make up the system and make sure that the OMRON products are used well within their rated specifications and performances. Safety measures, such as safety circuits, must be implemented in order to minimize the risks in the event of a malfunction.
- Thoroughly read and understand the manuals for all devices and equipment that will make up the system to ensure that the system is used safely. Review the entire contents of these manuals, including all safety precautions, precautions for safe use, and precautions for correct use.
- Confirm all regulations, standards, and restrictions that the system must adhere to.
- Check the user program for proper execution before you use it for actual operation.

Trademarks

- Microsoft product screen shot(s) reprinted with permission from Microsoft Corporation.
- Other company names and product names in this Guide are the trademarks or registered trademarks of their respective companies.

Revision History

A manual revision code appears as a suffix to the catalog number on the front and back covers of the manual.

Cat. No.	I877-E1-01
-----------------	-------------------

↑
Revision code

Revision code	Date	Revised content
01	April 2022	Original production

CONTENTS

Introduction.....	3
Intended Audience	3
Applicable Products	3
Terms and Conditions Agreement	4
Precautions	6
Trademarks.....	6
Revision History	7
1. Outline.....	9
2. Precautions for Replacement.....	10
3. Replacement List.....	11
3.1. Servomotors with Rated Rotation Speed of 3,000 r/min	11
3.2. Flat Servomotors with Rated Rotation Speed of 3,000 r/min	11
3.3. Servomotors with Rated Rotation Speed of 2,000 r/min and 1,500 r/min	11
3.4. Servomotors with Rated Rotation Speed of 1,000 r/min	12
4. Comparison of Servomotor Dimensions	13
4.1. Servomotors with Rated Rotation Speed of 3,000 r/min (Main Circuit Power Supply Voltage: 100 V or 200 V)	13
4.2. Servomotors with Rated Rotation Speed of 2,000 r/min (Main Circuit Power Supply Voltage: 200 V)	17
4.3. Servomotors with Rated Rotation Speed of 1,500 r/min (Main Circuit Power Supply Voltage: 200 V)	18
4.4. Servomotors with Rated Rotation Speed of 1,000 r/min (Main Circuit Power Supply Voltage: 200 V)	19
5. Comparison of Servo Drive Dimensions	21
6. Layout and Specifications of Connectors and Terminal Blocks of Servo Drive	23
6.1. Layout and Specifications of Connectors and Terminal Blocks of Main Circuit Wiring and Motor Wiring	23
6.2. Layout and Specifications of Connectors of Control Circuit	28
7. Gain Adjustment Methods	34
7.1. Gain Adjustment Method (Auto Tuning).....	34
7.2. Using Gain Adjustment Values for G Series as Those for G5 Series	39
8. Connecting with Host Controllers	40
8.1. For Host Controllers of Pulse Output Type Example: Position Control Unit (for CJ Series) Such as CJ1W-NC□□3.....	40
8.2. For Host Controllers of Analog Output Type Example: Motion Control Unit (for CS1 Series) Such as CS1W-MC□21-V1	41
8.3. Transferring Absolute (Absolute Value) Encoder Data to Host Controllers Target: Position Control Unit (High-Speed Type) CJ1W-NC□□4, Motion Control Unit (for CS1 Series) CS1W-MC□21-V1	42
9. Detailed Comparison of Parameters	44
9.1. Function Selection Parameters	44
9.2. Parameters Related to Gain	47
9.3. Parameters Related to Position Control	53
9.4. Parameters Related to Speed and Torque Control	55
9.5. Parameters Related to Sequence	57
Appendix. List of Cables Connecting G5-series Servo Drives and Servomotors.....	60

1. Outline

Thank you for adopting the Omron Servomotors and Servo Drives.

This manual describes the comparative information for replacing the conventional G-series AC Servomotors/Servo Drives with General-purpose Pulse Train or Analog Input, R88M-G and R88D-GT□, (hereinafter called the G series or G) with the G5-series AC Servomotors/Servo Drives with General-purpose Pulse Train or Analog Input, R88M-K and R88D-KT□, (hereinafter called the G5 series or G5).

To check the details that are not described in this manual, refer to the User's Manual for the Servomotors and Servo Drives concerned.

No.	Manual No.	Manual name
1.	I562	R88M-G□, R88D-GT□ AC Servomotors/Servo Drives with General-purpose Pulse Train or Analog Input G series User's Manual
2.	I571	R88M-K□, R88D-KT□ AC Servomotors/Servo Drives with General-purpose Pulse Train or Analog Input G5 series User's Manual

2. Precautions for Replacement

The following table shows the precautions for replacing the G series with the G5 series.

Read the comparisons of both series shown in this manual and the User's Manual of both series, before considering replacement.

No.	Classification	Item	G series	G5 series	Remarks
1.	Specifications and performance	Speed response frequency	1 kHz	2 kHz	Both the specifications and performance are improved in the G5 series.
2.		Encoder resolution	<ul style="list-style-type: none"> Incremental encoder Phases A and B: 2,500 pulses/rotation (Multiple of 4: 10,000 pulses/rotation) Absolute (absolute value) encoder 17 bits Phases A and B: 32,768 pulses/rotation (Multiple of 4: 131,072 pulses/rotation) 	<ul style="list-style-type: none"> Incremental encoder Phases A and B: 262,144 pulses/rotation (Multiple of 4: 1,048,576 pulses/rotation) Absolute (absolute value) encoder 17 bits Phases A and B: 32,768 pulses/rotation (Multiple of 4: 131,072 pulses/rotation) 	
3.		Output signal	There are six output signals: <ul style="list-style-type: none"> Brake Interlock (fixed) Servo Ready Output (fixed) Alarm Output (fixed) Positioning Completion Output (fixed) General-purpose Output 1 (set by Pn0A) General-purpose Output 2 (set by Pn09) 	There are four output signals: <ul style="list-style-type: none"> General-purpose output 1 (set by Pn410) General-purpose output 2 (set by Pn411) Alarm output (fixed) General-purpose output 4 (set by Pn413) 	The G5 series has less output signals by two. Set appropriate functions to the general-purpose outputs to make adjustments.
4.		Parameter Unit	Present	Absent	For the G5 series, parameters are set from CX-Drive (computer tool).
5.	Servomotor dimensions	Standard type	Example) 100 W motor: □40×92	Example) 100 W motor: □40×92	Same in dimensions.
6.		Flat type	Example) 100 W motor: □60×60.5	Example) 100 W motor: □40×92	The G5 series has no flat Servomotors, so the dimensions are significantly different.
7.		Comparison of dimensions between R88M-G1K030T□ and R88M-K1K030T□	<ul style="list-style-type: none"> Without brake: □90×175 With brake: □90×200 	<ul style="list-style-type: none"> Without brake: □100×141 With brake: □100×168 	The motor frame is enlarged from □90 to □100.
8.		Comparison of dimensions between R88M-G4K020T□ and R88M-K4K020T□	<ul style="list-style-type: none"> Without brake: □150×242 With brake: □150×267 	<ul style="list-style-type: none"> Without brake: □176×177 With brake: □176×206 	The motor frame is enlarged from □150 to □176.
9.		Drip-proof structure	IP65	IP67	It is improved in the G5 series.
10.	Servo Drive dimensions	Drive body	Example) 100 W drive: 150×40×130	Example) 100 W drive: 150×40×130	Same in dimensions.
11.		Installation style of R88D-GT75H and R88D-KT75H.	Front mounting only	Wall mounting and front mounting	The G5 series supports both wall mounting and front mounting.
12.	Function	STO function	Absent	Present	All the functions are covered because of upward compatibility. However, parameter Nos. are different, so refer to 9. <i>Detailed Comparison of Parameters.</i>
13.		RS-232/485 function	Present	Absent (Substituted with USB function)	
14.		Fully-closed control	Absent	Present	

3. Replacement List

3.1. Servomotors with Rated Rotation Speed of 3,000 r/min

Main circuit power supply voltage	G series			G5 series			Remarks
	Motor capacity	Motor model R88M-	Drive model R88D-	Motor capacity	Motor model R88M-	Drive model R88D-	
Single-phase 100 V	50 W	G05030H/T□	GTA5L	50 W	K05030H/T□	KTA5L	Compatible with 200-V Servomotors.
	100 W	G10030L/S□	GT01L	100 W	K10030L/S□	KT01L	
	200 W	G20030L/S□	GT02L	200 W	K20030L/S□	KT02L	
	400 W	G40030L/S□	GT04L	400 W	K40030L/S□	KT04L	
Single-phase 200 V	50 W	G05030H/T□	GT01H	50 W	K05030H/T□	KT01H	
	100 W	G10030H/T□	GT01H	100 W	K10030H/T□	KT01H	
	200 W	G20030H/T□	GT02H	200 W	K20030H/T□	KT02H	
	400 W	G40030H/T□	GT04H	400 W	K40030H/T□	KT04H	
	750 W	G75030H/T□	GT08H	750 W	K75030H/T□	KT08H	
	1 kW	G1K030T□	GT15H	1 kW	K1K030T□	KT15H	
	1.5 kW	G1K530T□	GT15H	1.5 kW	K1K530T□	KT15H	
3-phase 200 V	750 W	G75030H/T□	GT08H	750 W	K75030H/T□	KT08H	The motor flange dimension is changed from □90 to □100.
	1 kW	G1K030T□	GT15H	1 kW	K1K030T□	KT15H	
	1.5 kW	G1K530T□	GT15H	1.5 kW	K1K530T□	KT15H	
	2 kW	G2K030T□	GT20H	2 kW	K2K030T□	KT20H	
	3 kW	G3K030T□	GT30H	3 kW	K3K030T□	KT30H	
	4 kW	G4K030T□	GT50H	4 kW	K4K030T□	KT50H	
	5 kW	G5K030T□	GT50H	5 kW	K5K030T□	KT50H	

3.2. Flat Servomotors with Rated Rotation Speed of 3,000 r/min

Main circuit power supply voltage	G series			G5 series			Remarks
	Motor capacity	Motor model R88M-	Drive model R88D-	Motor capacity	Motor model R88M-	Drive model R88D-	
Single-phase 100 V	100 W	GP10030L/S□	GT01L	100 W	K10030L/S□	KT01L	The G5 series has no flat type of Servomotors, so the external dimensions are significantly different.
	200 W	GP20030L/S□	GT02L	200 W	K20030L/S□	KT02L	
	400 W	GP40030L/S□	GT04L	400 W	K40030L/S□	KT04L	
Single-phase 200 V	100 W	GP10030H/T□	GT01H	100 W	K10030H/T□	KT01H	
	200 W	GP20030H/T□	GT02H	200 W	K20030H/T□	KT02H	
	400 W	GP40030H/T□	GT04H	400 W	K40030H/T□	KT04H	

3.3. Servomotors with Rated Rotation Speed of 2,000 r/min and 1,500 r/min

Main circuit power supply voltage	G series			G5 series			Remarks
	Motor capacity	Motor model R88M-	Drive model R88D-	Motor capacity	Motor model R88M-	Drive model R88D-	
Single-phase 200 V	1 kW	G1K020T□	GT10H	1 kW	K1K020T□	KT10H	
	1.5 kW	G1K520T□	GT15H	1.5 kW	K1K520T□	KT15H	
3-phase 200 V	1 kW	G1K020T□	GT10H	1 kW	K1K020T□	KT10H	The motor flange dimension is changed from □150 to □176.
	1.5 kW	G1K520T□	GT15H	1.5 kW	K1K520T□	KT15H	
	2 kW	G2K020T□	GT20H	2 kW	K2K020T□	KT20H	
	3 kW	G3K020T□	GT30H	3 kW	K3K020T□	KT30H	
	4 kW	G4K020T□	GT50H	4 kW	K4K020T□	KT50H	
	5 kW	G5K020T□	GT50H	5 kW	K5K020T□	KT50H	
	7.5 kW	G7K515T□	GT75H	7.5 kW	K7K515T□	KT75H	

3.4. Servomotors with Rated Rotation Speed of 1,000 r/min

Main circuit power supply voltage	G series			G5 series			Remarks
	Motor capacity	Motor model R88M-	Drive model R88D-	Motor capacity	Motor model R88M-	Drive model R88D-	
Single-phase 200 V	900 W	G90010T□	GT15H	900 W	K90010T□	KT15H	
3-phase 200 V	900 W	G90010T□	GT15H	900 W	K90010T□	KT15H	
	2 kW	G2K010T□	GT30H	2 kW	K2K010T□	KT30H	
	3 kW	G3K010T□	GT50H	3 kW	K3K010T□	KT50H	
	4.5 kW	G4K510T□	GT50H	4.5 kW	K4K510T□	KT50H	
	6 kW	G6K010T□	GT75H	6 kW	K6K010T□	KT75H	

4. Comparison of Servomotor Dimensions

Since the G series and the G5 series are different in Servomotor dimensions, check the following comparison of dimensions in designing.

- Leaders and dimensions (symbols) on outline drawings and dimensional drawings are shown in red for ease of recognition.
- For dimensions (numbers) in tables, the dimensions becoming larger and smaller when the G series is replaced with the G5 series are respectively shown in red and blue.

4.1. Servomotors with Rated Rotation Speed of 3,000 r/min (Main Circuit Power Supply Voltage: 100 V or 200 V)

■ 50 W or 100 W motor (100 V or 200 V)

- G without 50 W or 100 W brake

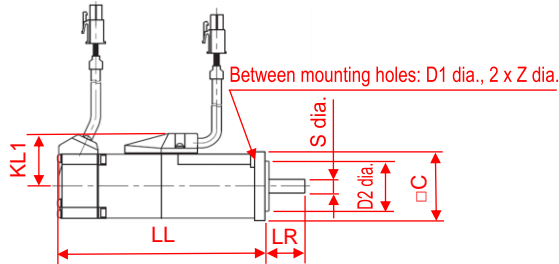

- G with 50 W or 100 W brake

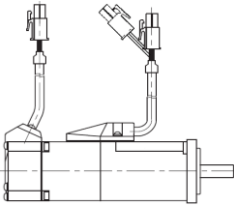

- G5 without 50 W or 100 W brake

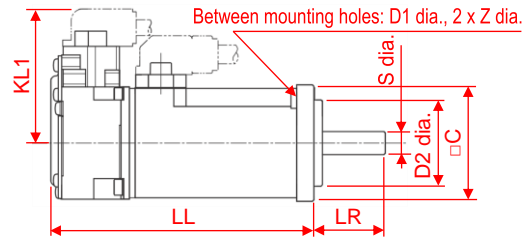

- G5 with 50 W or 100 W brake

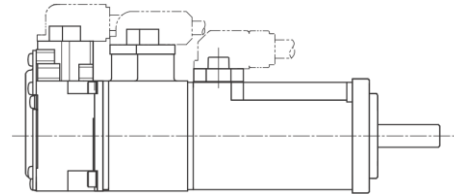

Motor capacity	Specifications	Series	Motor model R88M-	Dimension [mm]								Remarks
				LL	LR	S	D1	D2	C	Z	KL1	
50 W	Without brake	G series	G05030□	72	25	8	46	30	40	4.3	32	Connectors are located differently. • For G, connectors are located on the lead cable ends. • For G5, connectors are located on the Servomotor body.
		G5 series	K05030□	72	25	8	46	30	40	4.3	46.6	
	With brake	G series	G05030□-B□	102	25	8	46	30	40	4.3	32	
		G5 series	K05030□-B□	102	25	8	46	30	40	4.3	46.6	
100 W	Without brake	G series	G10030□	92	25	8	46	30	40	4.3	32	
		G5 series	K10030□	92	25	8	46	30	40	4.3	46.6	
	With brake	G series	G10030□-B□	122	25	8	46	30	40	4.3	32	
		G5 series	K10030□-B□	122	25	8	46	30	40	4.3	46.6	

■ 200 W or 400 W motor (100 V or 200 V)

● G without 200 W or 400 W brake

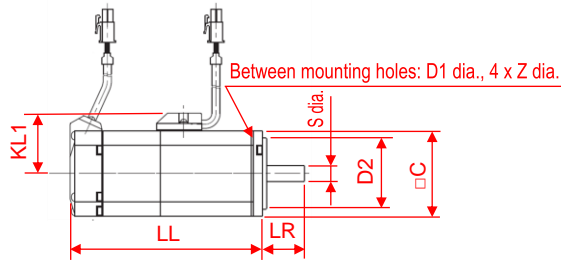

● G with 200 W or 400 W brake

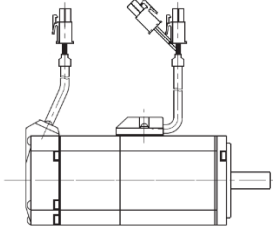

● G5 without 200 W or 400 W brake

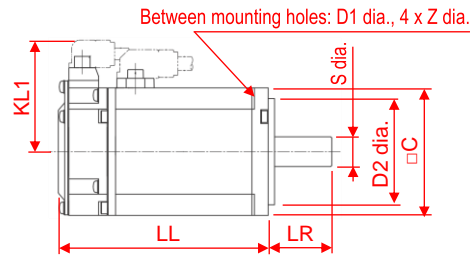

● G5 with 200 W or 400 W brake

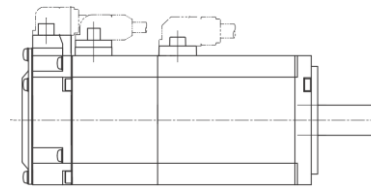

Motor capacity	Specifications	Series	Motor model R88M-	Dimension [mm]								Remarks
				LL	LR	S	D1	D2	C	Z	KL1	
200 W	Without brake	G series	G20030□	79.5	30	11	70	50	60	4.5	43	Connectors are located differently. ● For G, connectors are located on the lead cable ends. ● For G5, connectors are located on the Servomotor body.
		G5 series	K20030□	79.5	30	11	70	50	60	4.5	52.5	
	With brake	G series	G20030□-B□	116	30	11	70	50	60	4.5	43	
		G5 series	K20030□-B□	116	30	11	70	50	60	4.5	52.5	
400 W	Without brake	G series	G40030□	99	30	14	70	50	60	4.5	43	
		G5 series	K40030□	99	30	14	70	50	60	4.5	52.5	
	With brake	G series	G40030□-B□	135.5	30	14	70	50	60	4.5	43	
		G5 series	K40030□-B□	135.5	30	14	70	50	60	4.5	52.5	

■ 750 W motor (200 V)

● G without 750 W brake

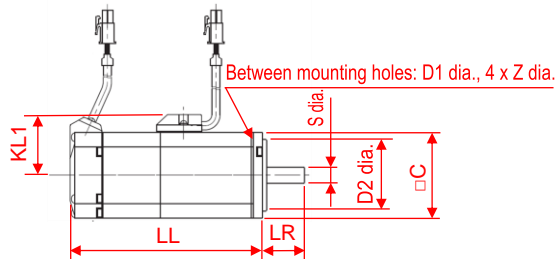

● G with 750 W brake

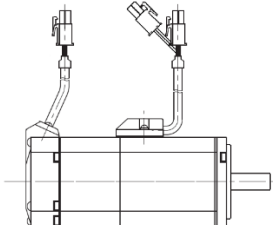

● G5 without 750 W brake

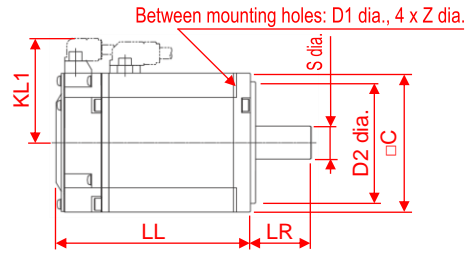

● G5 with 750 W brake

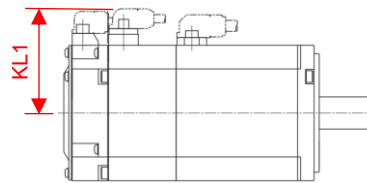

Motor capacity	Specifications	Series	Motor model R88M-	Dimension [mm]								Remarks
				LL	LR	S	D1	D2	C	Z	KL1	
750 W	Without brake	G series	G75030□	112.2	35	19	90	70	80	6	53	Connectors are located differently. ● For G, connectors are located on the lead cable ends. ● For G5, connectors are located on the Servomotor body.
		G5 series	K75030□	112.2	35	19	90	70	80	6	60	
	With brake	G series	G75030□-B□	149.2	35	19	90	70	80	6	53	
		G5 series	K75030□-B□	148.2	35	19	90	70	80	6	61.6	

■ 1 kW, 1.5 kW, 2 kW, 3 kW, 4 kW, or 5 kW motor (200 V)

● G of 1 kW, 1.5 kW, 2 kW, 3 kW, 4 kW, or 5 kW

● G5 of 1 kW, 1.5 kW, 2 kW, 3 kW, 4 kW, or 5 kW

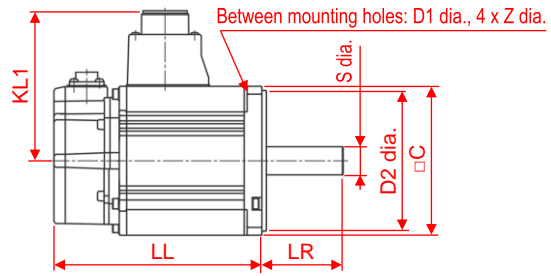
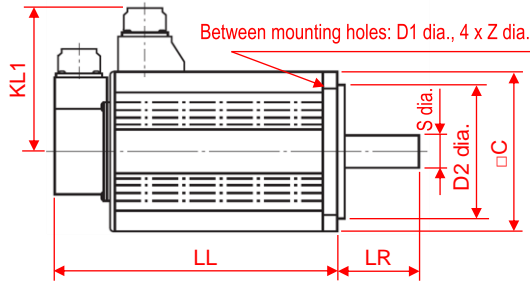

Motor capacity	Specifications	Series	Motor model R88M-	Dimension [mm]								Remarks
				LL	LR	S	D1	D2	C	Z	KL1	
1 kW	Without brake	G series	G1K030T□	175	55	19	100	80	90	6.6	98	Connector directions are the same.
		G5 series	K1K030T□	141	55	19	115	95	100	9	101	
	With brake	G series	G1K030T-B□	200	55	19	100	80	90	6.6	98	
		G5 series	K1K030T-B□	168	55	19	115	95	100	9	101	
1.5 kW	Without brake	G series	G1K530T□	180	55	19	115	95	100	9	103	
		G5 series	K1K530T□	159.5	55	19	115	95	100	9	101	
	With brake	G series	G1K530T-B□	205	55	19	115	95	100	9	103	
		G5 series	K1K530T-B□	186.5	55	19	115	95	100	9	101	
2 kW	Without brake	G series	G2K030T□	205	55	19	115	95	100	9	103	
		G5 series	K2K030T□	178.5	55	19	115	95	100	9	101	
	With brake	G series	G2K030T-B□	230	55	19	115	95	100	9	103	
		G5 series	K2K030T-B□	205.5	55	19	115	95	100	9	101	
3 kW	Without brake	G series	G3K030T□	217	55	22	145	110	120	9	111	
		G5 series	K3K030T□	190	55	22	145	110	120	9	113	
	With brake	G series	G3K030T-B□	242	55	22	145	110	120	9	111	
		G5 series	K3K030T-B□	215	55	22	145	110	120	9	113	
4 kW	Without brake	G series	G4K030T□	240	65	24	145	110	130	9	118	
		G5 series	K4K030T□	208	65	24	145	110	130	9	118	
	With brake	G series	G4K030T-B□	265	65	24	145	110	130	9	118	
		G5 series	K4K030T-B□	236	65	24	145	110	130	9	118	
5 kW	Without brake	G series	G5K030T□	280	65	24	145	110	130	9	118	
		G5 series	K5K030T□	243	65	24	145	110	130	9	118	
	With brake	G series	G5K030T-B□	305	65	24	145	110	130	9	118	
		G5 series	K5K030T-B□	271	65	24	145	110	130	9	118	

■ 100 W, 200 W, or 400 W flat Servomotors (100 V or 200 V)

- G without 100 W, 200 W, or 400 W brake

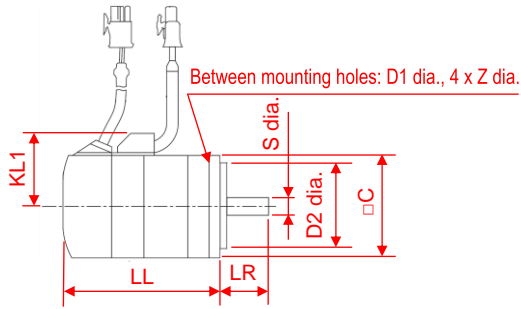

- G with 100 W, 200 W, or 400 W brake

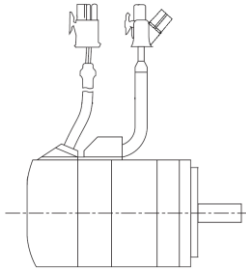

- G5 without 100 W, 200 W, or 400 W brake

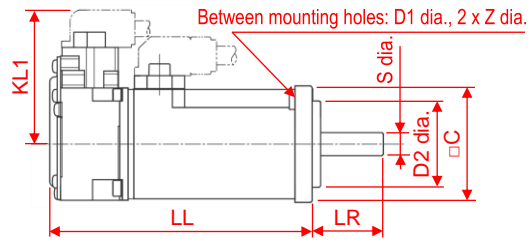

- G5 with 100 W, 200 W, or 400 W brake

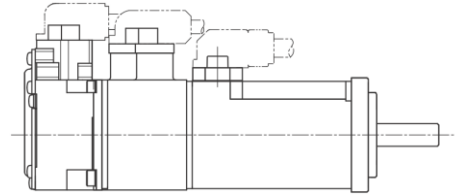

Motor capacity	Specifications	Series	Motor model R88M-	Dimension [mm]								Remarks
				LL	LR	S	D1	D2	C	Z	KL1	
100 W	Without brake	G series	GP10030L□	60.5	25	8	70	50	60	4.5	43	Connectors are located differently. • For G, connectors are located on the lead cable ends. • For G5, connectors are located on the Servomotor body.
			GP10030H□									
			GP10030S□	87.5								
			GP10030T□									
	G5 series	K10030□	92									
		With brake	G series	GP10030L-B□	84.5	25	8	70	50	60	4.5	
GP10030H-B□												
GP10030S-B□	111.5											
GP10030T-B□												
G5 series	K10030□-B□	122										
	200 W	Without brake	G series	GP20030L□	67.5	30	11	90	70	80	5.5	
GP20030H□												
GP20030S□				94.5								
GP20030T□												
G5 series		K20030□	79.5									
		With brake	G series	GP20030L-B□	100	30	11	90	70	80	5.5	53
GP20030H-B□												
GP20030S-B□	127											
GP20030T-B□												
G5 series	K20030□-B□	116										
	400 W	Without brake	G series	GP40030L□	82.5	30	14	90	70	80	5.5	53
GP40030H□												
GP40030S□				109.5								
GP40030T□												
G5 series		K40030□	99									
		With brake	G series	GP40030L-B□	115	30	14	90	70	80	5.5	53
GP40030H-B□												
GP40030S-B□	142											
GP40030T-B□												
G5 series	K40030□-B□	135.5										

4.2. Servomotors with Rated Rotation Speed of 2,000 r/min (Main Circuit Power Supply Voltage: 200 V)

■ 1 kW, 1.5 kW, 2 kW, 3 kW, 4 kW, or 5 kW motor (200 V)

● G of 1 kW, 1.5 kW, 2 kW, 3 kW, 4 kW, or 5 kW

● G5 of 1 kW, 1.5 kW, 2 kW, 3 kW, 4 kW, or 5 kW

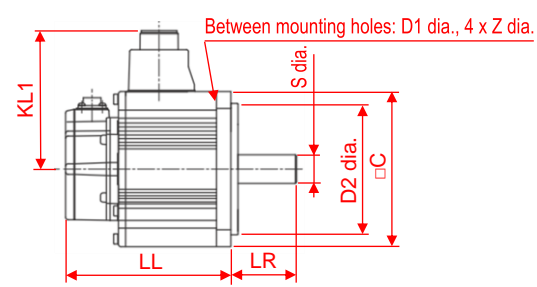
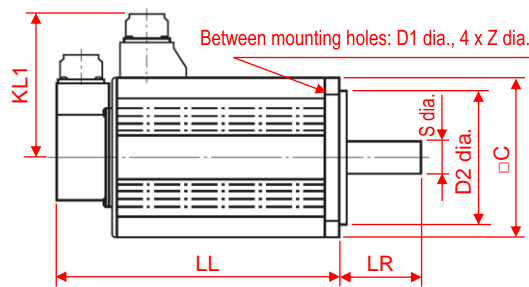

Motor capacity	Specifications	Series	Motor model R88M-	Dimension [mm]								Remarks
				LL	LR	S	D1	D2	C	Z	KL1	
1 kW	Without brake	G series	G1K020T□	150	55	22	145	110	130	9	118	Connector directions are the same.
		G5 series	K1K020T□	138	55	22	145	110	130	9	116	
	With brake	G series	G1K020T-B□	175	55	22	145	110	130	9	118	
		G5 series	K1K020T-B□	166	55	22	145	110	130	9	116	
1.5 kW	Without brake	G series	G1K520T□	175	55	22	145	110	130	9	118	
		G5 series	K1K520T□	155.5	55	22	145	110	130	9	116	
	With brake	G series	G1K520T-B□	200	55	22	145	110	130	9	118	
		G5 series	K1K520T-B□	183.5	55	22	145	110	130	9	116	
2 kW	Without brake	G series	G2K020T□	200	55	22	145	110	130	9	118	
		G5 series	K2K020T□	173	55	22	145	110	130	9	116	
	With brake	G series	G2K020T-B□	225	55	22	145	110	130	9	118	
		G5 series	K2K020T-B□	201	55	22	145	110	130	9	116	
3 kW	Without brake	G series	G3K020T□	250	65	24	145	110	130	9	118	
		G5 series	K3K020T□	208	65	24	145	110	130	9	118	
	With brake	G series	G3K020T-B□	275	65	24	145	110	130	9	118	
		G5 series	K3K020T-B□	236	65	24	145	110	130	9	118	
4 kW	Without brake	G series	G4K020T□	242	65	28	165	130	150	11	128	
		G5 series	K4K020T□	177	70	35	200	114.3	176	13.5	140	
	With brake	G series	G4K020T-B□	267	65	28	165	130	150	11	128	
		G5 series	K4K020T-B□	206	70	35	200	114.3	176	13.5	140	
5 kW	Without brake	G series	G5K020T□	225	70	35	200	114.3	176	13.5	143	
		G5 series	K5K020T□	196	70	35	200	114.3	176	13.5	140	
	With brake	G series	G5K020T-B□	250	70	35	200	114.3	176	13.5	143	
		G5 series	K5K020T-B□	225	70	35	200	114.3	176	13.5	140	

4.3. Servomotors with Rated Rotation Speed of 1,500 r/min (Main Circuit Power Supply Voltage: 200 V)

■ 7.5 kW motor (200 V)

● G of 7.5 kW

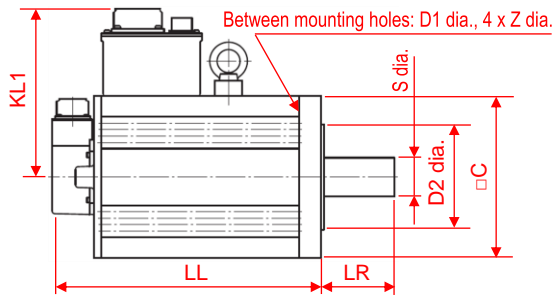

● G5 of 7.5 kW

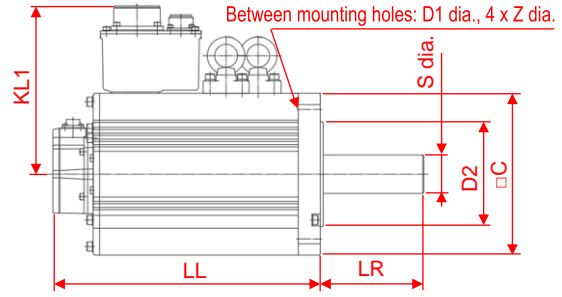

Motor capacity	Specifications	Series	Motor model R88M-	Dimension [mm]								Remarks
				LL	LR	S	D1	D2	C	Z	KL1	
7.5 kW	Without brake	G series	G7K515T□	340.5	113	42	200	114.3	176	13.5	183	Connector directions are the same.
		G5 series	K7K515T□	312	113	42	200	114.3	176	13.5	184	
	With brake	G series	G7K515T-B□	380.5	113	42	200	114.3	176	13.5	183	
		G5 series	K7K515T-B□	337	113	42	200	114.3	176	13.5	184	

4.4. Servomotors with Rated Rotation Speed of 1,000 r/min (Main Circuit Power Supply Voltage: 200 V)

■ 900 W, 2 kW, or 3 kW motor (200 V)

- G of 900 W, 2 kW, or 3 kW

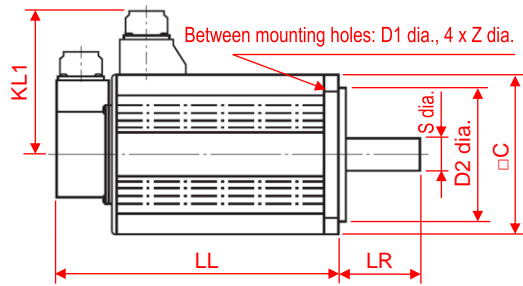

- G5 of 900 W, 2 kW, or 3 kW

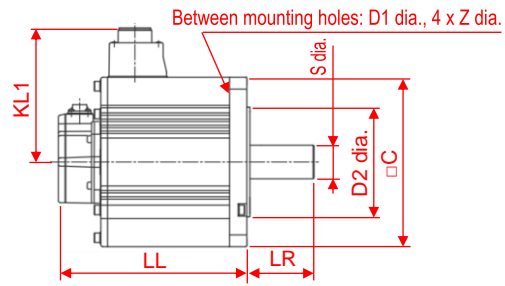

Motor capacity	Specifications	Series	Motor model R88M-	Dimension [mm]								Remarks
				LL	LR	S	D1	D2	C	Z	KL1	
900 W	Without brake	G series	G90010T□	175	70	22	145	110	130	9	118	Connector directions are the same.
		G5 series	K90010T□	155.5	70	22	145	110	130	9	116	
	With brake	G series	G90010T-B□	200	70	22	145	110	130	9	118	
		G5 series	K90010T-B□	183.5	70	22	145	110	130	9	116	
2 kW	Without brake	G series	G2K010T□	182	80	35	200	114.3	176	13.5	143	
		G5 series	K2K010T□	163.5	80	35	200	114.3	176	13.5	140	
	With brake	G series	G2K010T-B□	207	80	35	200	114.3	176	13.5	143	
		G5 series	K2K010T-B□	192.5	80	35	200	114.3	176	13.5	140	
3 kW	Without brake	G series	G3K010T□	222	80	35	200	114.3	176	13.5	143	
		G5 series	K3K010T□	209.5	80	35	200	114.3	176	13.5	140	
	With brake	G series	G3K010T-B□	271	80	35	200	114.3	176	13.5	143	
		G5 series	K3K010T-B□	238.5	80	35	200	114.3	176	13.5	140	

■ 4.5 kW motor (200 V)

● G of 4.5 kW

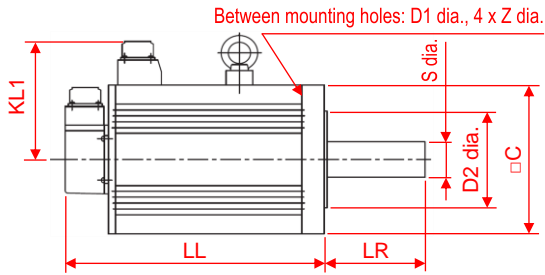

● G5 of 4.5 kW

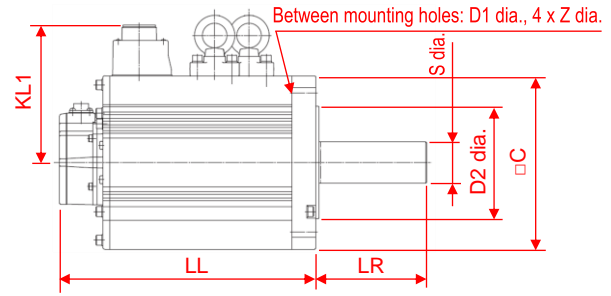

Motor capacity	Specifications	Series	Motor model R88M-	Dimension [mm]								Remarks
				LL	LR	S	D1	D2	C	Z	KL1	
4.5 kW	Without brake	G series	G4K510T□	300.5	113	42	200	114.3	176	13.5	143	Connector directions are the same.
		G5 series	K4K510T□	266	113	42	200	114.3	176	13.5	140	
	With brake	G series	G4K510T-B□	337.5	113	42	200	114.3	176	13.5	143	
		G5 series	K4K510T-B□	291	113	42	200	114.3	176	13.5	140	

■ 6 kW motor (200 V)

● G of 6 kW

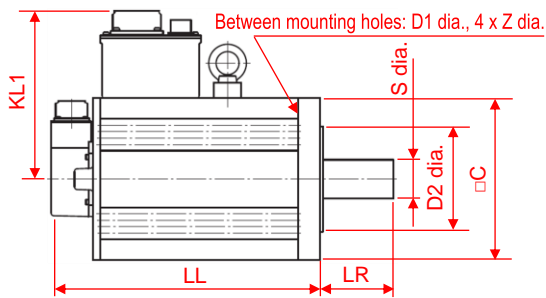

● G5 of 6 kW

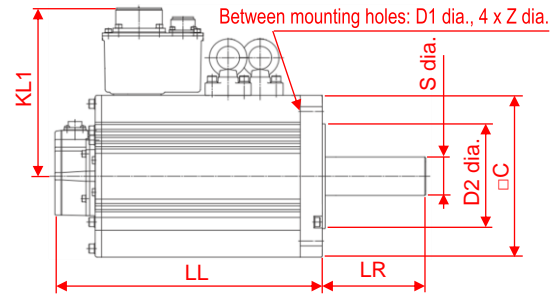

Motor capacity	Specifications	Series	Motor model R88M-	Dimension [mm]								Remarks
				LL	LR	S	D1	D2	C	Z	KL1	
6 kW	Without brake	G series	G6K010T□	340.5	113	42	200	114.3	176	13.5	183	Connector directions are the same.
		G5 series	K6K010T□	312	113	42	200	114.3	176	13.5	184	
	With brake	G series	G6K010T-B□	380.5	113	42	200	114.3	176	13.5	183	
		G5 series	K6K010T-B□	337	113	42	200	114.3	176	13.5	184	

5. Comparison of Servo Drive Dimensions

Since the G series and the G5 series are different in drive dimensions, check the following comparison of dimensions in designing.

- Leaders and dimensions (symbols) on outline drawings and dimensional drawings are shown in **red** for ease of recognition.
- For dimensions (numbers) in tables, the dimensions becoming larger and smaller when the G series is replaced with the G5 series are respectively shown in **red** and **blue**.

■ Reference outline drawings of drives

• G Drive R88D-GT01H

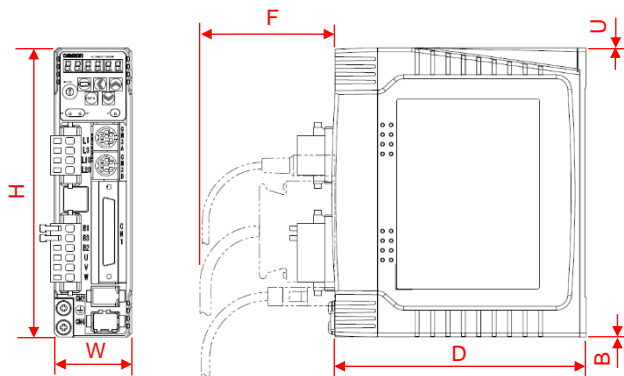

• G5 Drive R88D-KT01H

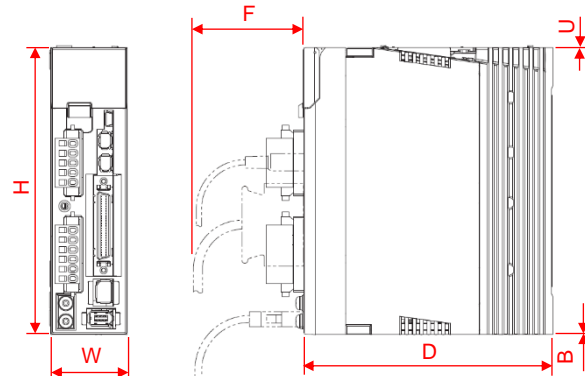

• G Drive R88D-GT20H

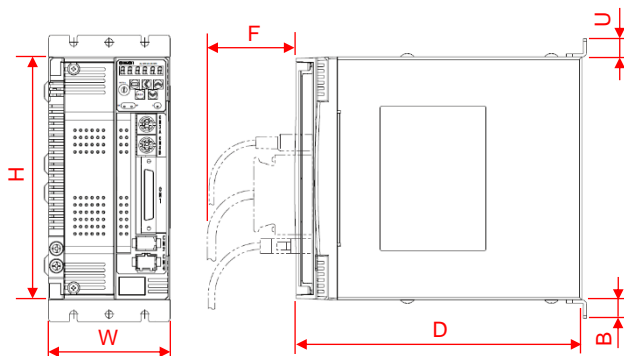

• G5 Drive R88D-KT20H

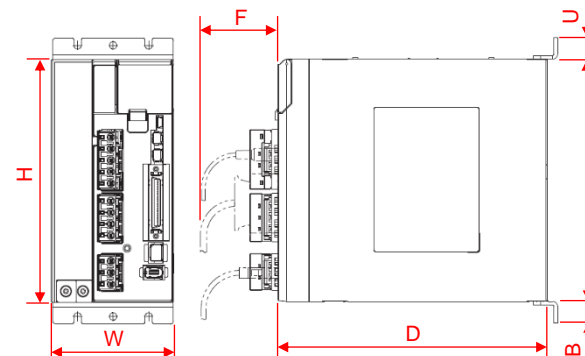

• G Drive R88D-GT75H

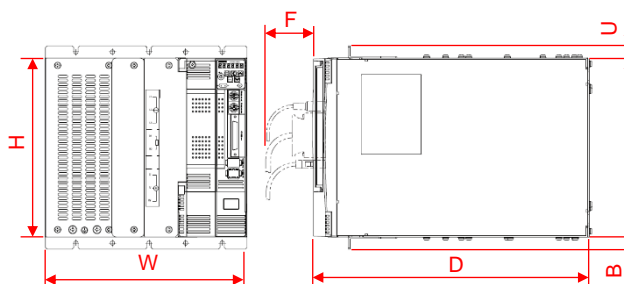

• G5 Drive R88D-KT75H

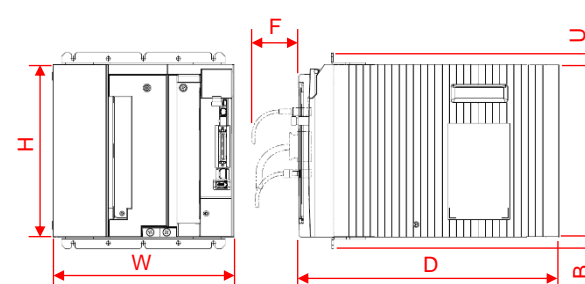

■ Main circuit power supply voltage 200 V drive dimensions

Motor capacity	Series	Drive model R88D-	Dimension [mm]						Remarks
			H	W	D	F	U	B	
100 W or 200 W	G series	GT01H/GT02H	150	40	130	70	0	0	
	G5 series	KT01H/KT02H	150	40	130	70	0	0	
400 W	G series	GT04H	150	55	130	70	0	0	
	G5 series	KT04H	150	55	130	70	0	0	
750 W	G series	GT08H	150	65	170	70	0	0	
	G5 series	KT08H	150	65	170	70	0	0	
1 kW or 1.5 kW	G series	GT10H/GT15H	150	85	170	70	0	0	
	G5 series	KT10H/KT15H	150	86	170	70	0	0	
2 kW	G series	GT20H	168	85	200	70	15	15	
	G5 series	KT20H	168	86	193.5	70	15	15	
3 kW or 5 kW	G series	GT30H/GT50H	220	130	200	70	15	15	
	G5 series	KT30H/KT50H	220	130	212	70	15	15	
7.5 kW	G series	GT75H	220	248	339.3	70	15	15	
	G5 series	KT75H	220	233	334	70	15	15	

- For G, front mounting is only allowed.
- For G5, wall mounting and front mounting are both allowed.

■ Main circuit power supply voltage 100 V drive dimensions

Motor capacity	Series	Drive model R88D-	Dimension [mm]						Remarks
			H	W	D	F	U	B	
50 W or 100 W	G series	GTA5L/GT01L	150	40	130	70	0	0	
	G5 series	KTA5L/KT01L	150	40	130	70	0	0	
200 W	G series	GT02L	150	55	130	70	0	0	
	G5 series	KT02L	150	55	130	70	0	0	
400 W	G series	GT04L	150	65	170	70	0	0	
	G5 series	KT04L	150	65	170	70	0	0	

6. Layout and Specifications of Connectors and Terminal Blocks of Servo Drive

The G5 series has inherited the layout and specifications of connectors and terminal blocks of the G series, so you can change wiring without great difficulty.

The below shows the layout and specifications of the connectors and terminal blocks of each drive model. Read the descriptions, and then consider replacement design.

6.1. Layout and Specifications of Connectors and Terminal Blocks of Main Circuit Wiring and Motor Wiring

- 50 W to 200 W drives (100 V) or 100 W to 400 W drives (200 V)
- G series: R88D-GTA5L/GT01L/GT02L/GT01H/GT02H/GT04H
- G5 series: R88D-KTA5L/ KT01L/KT02L/KT01H/KT02H/KT04H

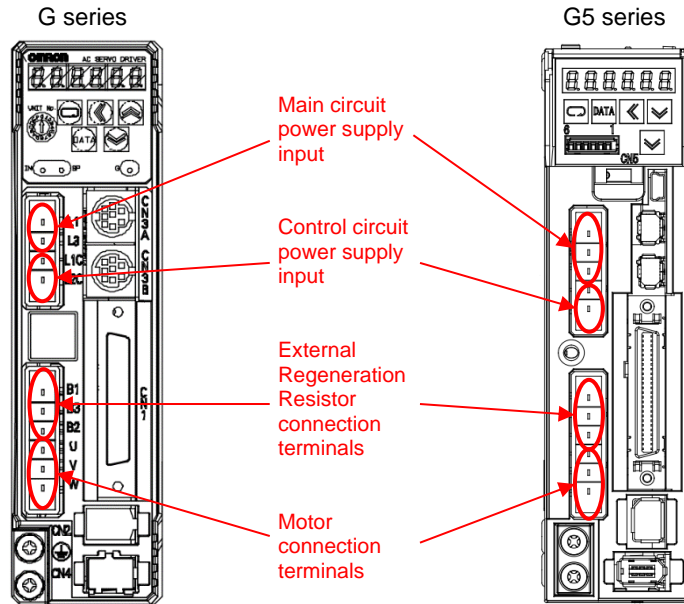

In both the G and the G5 series, input single-phase 100 V and 200 V to the L1 terminal and the L3 terminal.

G series				G5 series			
Terminal	Symbol	Name	Outline specifications	Terminal	Symbol	Name	Outline specifications
CNA	L1	Main circuit power supply input	Single-phase 100 to 115 VAC Single-phase 200 to 240 VAC	CNA	L1	Main circuit power supply input	Single-phase 100 to 120 VAC Single-phase 200 to 240 VAC 3-phase 200 to 240 VAC
	L3				L3		
	L1C	Control circuit power supply input	Single-phase 100 to 115 VAC Single-phase 200 to 240 VAC		L1C	Control circuit power supply input	Single-phase 100 to 120 VAC Single-phase 200 to 240 VAC
	L2C				L2C		
CNB	B1	External Regeneration Resistor connection terminals	Internal Regeneration Resistor: B2–B3 short-circuited External Regeneration Resistor: Resistor: B1–B2 connected	CNB	B1	External Regeneration Resistor connection terminals	Internal Regeneration Resistor: B2–B3 short-circuited External Regeneration Resistor: Resistor: B1–B2 connected
	B3				B3		
	B2				B2		
	U	Motor connection terminals	Motor output of phase U, phase V, and phase W		U	Motor connection terminals	Motor output of phase U, phase V, and phase W
	V				V		
W	W						

- 400 W drive (100 V) or 750 W to 1.5 kW drives (200 V)
- G series: R88D-GT04L/GT08H/GT10H/GT15H
- G5 series: R88D-KT04L/KT08H/KT10H/KT15H

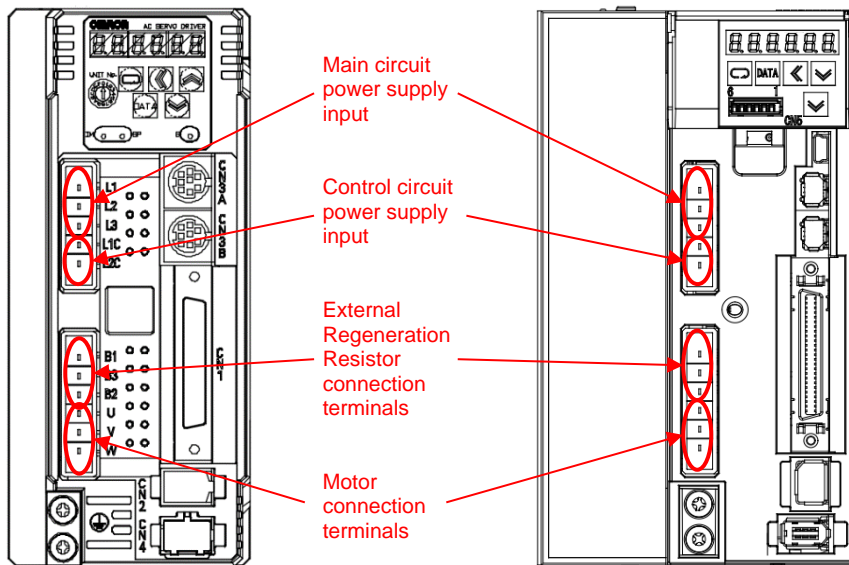

In both the G and the G5 series, input single-phase 100 V and 200 V to the L1 terminal and the L3 terminal.

G series				G5 series			
Terminal	Symbol	Name	Outline specifications	Terminal	Symbol	Name	Outline specifications
CNA	L1	Main circuit power supply input	Single-phase 100 to 115 VAC	CNA	L1	Main circuit power supply input	Single-phase 100 to 120 VAC
	L2		Single-phase 200 to 240 VAC		L2		Single-phase 200 to 240 VAC
	L3		3-phase 200 to 240 VAC		L3		3-phase 200 to 240 VAC
	L1C	Control circuit power supply input	Single-phase 100 to 115 VAC		L1C	Control circuit power supply input	Single-phase 100 to 120 VAC
L2C	Single-phase 200 to 240 VAC		L2C	Single-phase 200 to 240 VAC			
CNB	B1	External Regeneration Resistor connection terminals	Internal Regeneration Resistor: B2–B3 short-circuited External Regeneration Resistor: B1–B2 connected	CNB	B1	External Regeneration Resistor connection terminals	Internal Regeneration Resistor: B2–B3 short-circuited External Regeneration Resistor: B1–B2 connected
	B3				B3		
	B2				B2		
	U	Motor connection terminals	Motor output of phase U, phase V, and phase W		U	Motor connection terminals	Motor output of phase U, phase V, and phase W
V	V						
W	W						

■ 2 kW drive (200 V)
 G series: R88D-GT20H
 G5 series: R88D-KT20H

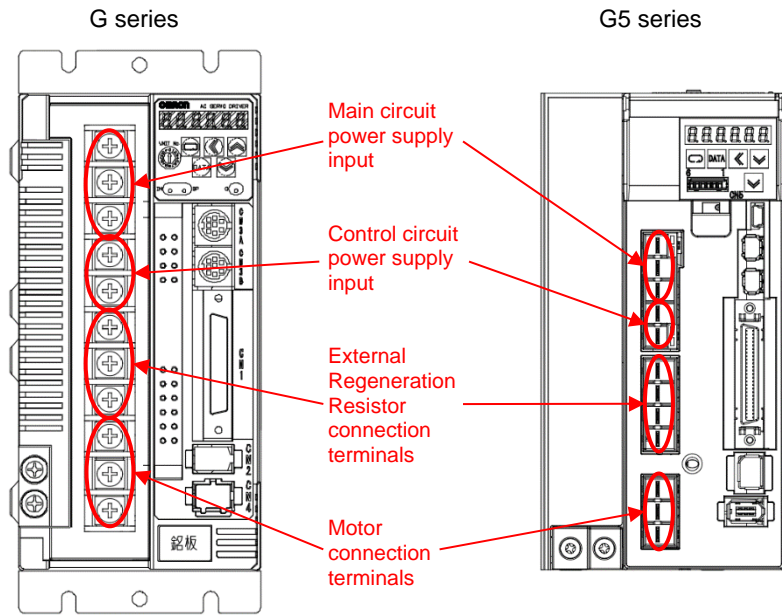

G series				G5 series			
Terminal	Symbol	Name	Outline specifications	Terminal	Symbol	Name	Outline specifications
TB	L1	Main circuit power supply input	3-phase 200 to 230 VAC	CNA	L1	Main circuit power supply input	3-phase 200 to 230 VAC
	L2				L2		
	L3				L3		
	L1C	Control circuit power supply input	Single-phase 200 to 230 VAC	L1C	Control circuit power supply input	Single-phase 200 to 230 VAC	
	L2C			L2C			
	B1	External Regeneration Resistor connection terminals	Internal Regeneration Resistor: B2-B3 short-circuited External Regeneration Resistor: B1-B2 connected	CNC	B1	External Regeneration Resistor connection terminals	Internal Regeneration Resistor: B2-B3 short-circuited External Regeneration Resistor: B1-B2 connected
	B3				B3		
B2	B2						
U	Motor connection terminals	Motor output of phase U, phase V, and phase W	NC	-	Do not connect.		
V			CNCB	U	Motor connection terminals	Motor output of phase U, phase V, and phase W	
W				V			
				W			

■ 3 kW to 5 kW drives (200 V)
 G series: R88D-GT30H/GT50H
 G5 series: R88D-KT30H/KT50H

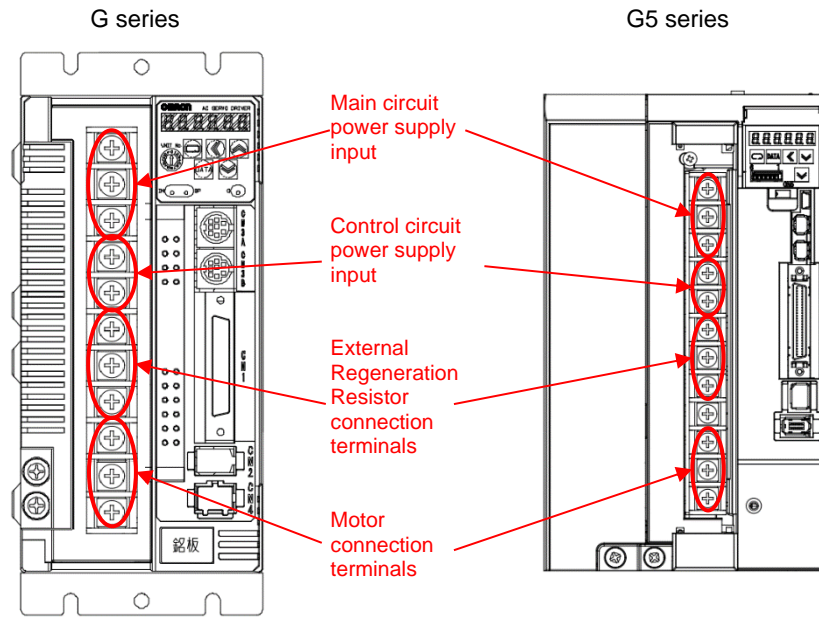

G series				G5 series			
Terminal	Symbol	Name	Outline specifications	Terminal	Symbol	Name	Outline specifications
TB	L1	Main circuit power supply input	3-phase 200 to 230 VAC	TB	L1	Main circuit power supply input	3-phase 200 to 230 VAC
	L2				L2		
	L3				L3		
	L1C	Control circuit power supply input	Single-phase 200 to 230 VAC		L1C	Control circuit power supply input	Single-phase 200 to 230 VAC
	L2C				L2C		
	B1	External Regeneration Resistor connection terminals	Internal Regeneration Resistor: B2–B3 short-circuited External Regeneration Resistor: B1–B2 connected		B1	External Regeneration Resistor connection terminals	Internal Regeneration Resistor: B2–B3 short-circuited External Regeneration Resistor: B1–B2 connected
	B3				B3		
B2			B2				
U	Motor connection terminals	Motor output of phase U, phase V, and phase W	NC	-	Do not connect.		
V			U	Motor connection terminals	Motor output of phase U, phase V, and phase W		
W			V				
				W			

■ 7.5 kW drive (200 V)
 G series: R88D-GT75H
 G5 series: R88D-KT75H

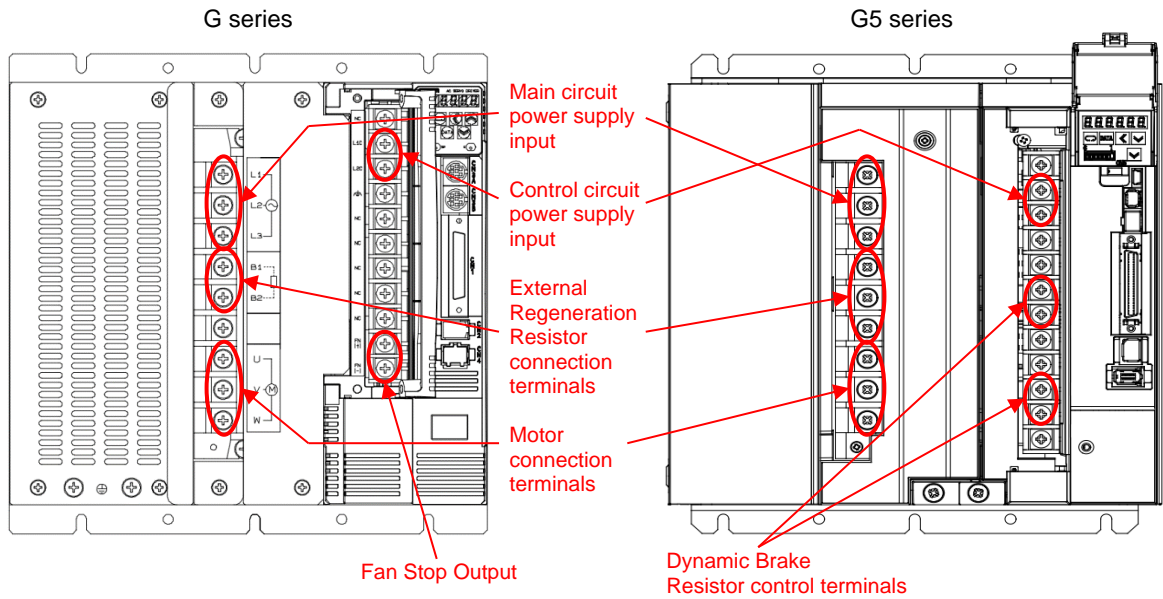

G series				G5 series				
Terminal	Symbol	Name	Outline specifications	Terminal	Symbol	Name	Outline specifications	
TB1	L1	Main circuit power supply input	3-phase 200 to 230 VAC	TB1	L1	Main circuit power supply input	3-phase 200 to 230 VAC	
	L2				L2			
	L3				L3			
	B1	External Regeneration Resistor connection terminals	Internal Regeneration Resistor: Not supported External Regeneration Resistor: B1–B2 connected		TB1	B1	External Regeneration Resistor connection terminals	Internal Regeneration Resistor: Not supported External Regeneration Resistor: B1–B2 connected
	B2		B2					
	NC	-	Do not connect.		N	-	Do not connect.	
U	Motor connection terminals	Motor output of phase U, phase V, and phase W	U	Motor connection terminals	Motor output of phase U, phase V, and phase W			
V			V					
W			W					
TB2	NC	-	Do not connect.	TB2	NC	-	Do not connect.	
	L1C	Control circuit power supply input	Single-phase 200 to 230 VAC		L1C	Control circuit power supply input	Single-phase 200 to 230 VAC	
	L2C				L2C			
	⊕	Frame ground			This is a ground terminal.	NC		-
	NC	-	Do not connect.		NC	-	Do not connect.	
	EX1				DB1	DB resistance control terminals*1	The DB1–DB2 output controls external dynamic brake resistor contacts.	
	EX2				DB2			
	EX2				NC	-	Do not connect.	
	NC	-	Do not connect.		NC	-	Do not connect.	
	FN(+)	Fan Stop Output			This is a drive internal fan stop warning output (30 VDC-50 mA or less).	DB3	DB resistance control terminals*1	Internal resistor: DB3–DB4 short-circuited External resistor: DB3–DB4 open
FN(-)	DB4							
NC	-	Do not connect.	NC	-	Do not connect.			

*1. Formally called *Dynamic Brake Resistor control terminals*.

6.2. Layout and Specifications of Connectors of Control Circuit

Layout of connectors of control circuit

The control circuit connectors are arranged on the drive front.

The G5 series does not support the RS-485 communications, RS-232 communications, and Parameter Unit functions of the G series.

For the G5 series, parameters can be set from CX-Drive (computer tool) via USB communications.

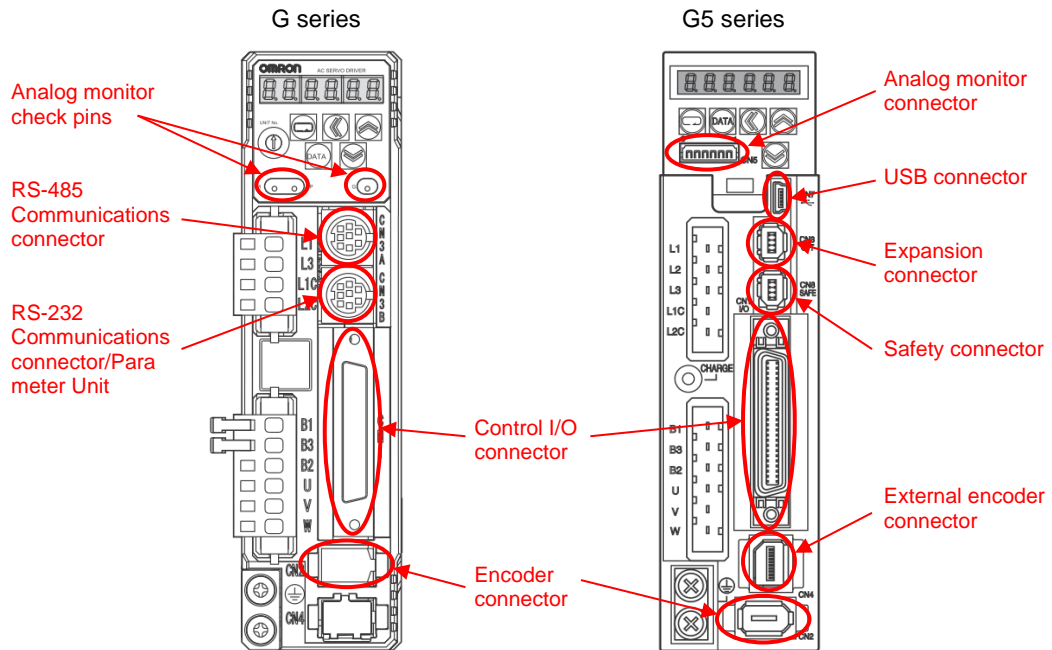

Control I/O connector

Pulse input

When you select position control (pulse train command) mode, input command pulses from the following pulse inputs. Select them according to the specifications of the host controller, then install wiring and set parameters.

Host controller pulse output circuit	Host controller specifications	Maximum input frequency of drive	CW (reverse) pulse input	CCW (forward) pulse input
Open collector	24 V power supply	200 kpps (multiple of 4) or less	1–4 pins	2–6 pins
	5 V power supply		3–4 pins	5–6 pins
Line driver	500 kpps (multiple of 4) or less	500 kpps (multiple of 4) or less	3–4 pins	5–6 pins
	500 kpps (multiple of 4) or more	G series: 2 Mpps (multiple of 4) or less G5 series: 4 Mpps (multiple of 4) or less	44–45 pins	46–47 pins

* Photocoupler inputs (1 to 6 pins) and line driver-specific inputs (44 to 47 pins) of pulse inputs are selected by using **Command Pulse Input Selection** (Pn40/Pn005). In both the G and the G5 series, the default setting is 0: *Photocoupler input (1 to 6 pins)*.

G series				G5 series			
Terminal	No.	Symbol	Name	Terminal	No.	Symbol	Name
CN1	1	+24VCW	24-V Open-collector Input for Command Pulse	CN1	1	+24VCW	24-V open-collector input for command pulse
	2	+24VCCW			2	+24VCCW	
	3	+CW/PULS/FA	Reverse Pulses Input/Feed Pulses Input, or 90° Phase Difference Pulse Input (Phase A)		3	+CW/+PULS/+FA	Reverse pulse, feed pulse, or 90° phase difference signal (phase A)
	4	-CW/PULS/FA			4	-CW/-PULS/-FA	
	5	+CCW/SIGN/FB	Forward Pulse Input/Direction Signal, or 90° Phase Difference Pulse Input (Phase B)		5	+CCW/+SIGN/+FB	Forward pulse, direction signal, or 90° phase difference signal (phase B)
	6	-CCW/SIGN/FB			6	-CCW/-SIGN/-FB	
	44	+CWLD	Reverse Pulse (input for line driver only)		44	+CWLD	Reverse pulse (input for line driver only)
45	-CWLD		45	-CWLD			
46	+CCWLD	Forward Pulse (input for line driver only)	46	+CCWLD	Forward pulse (input for line driver only)		
47	-CCWLD		47	-CCWLD			

[Electrical specifications]

- In both the G and the G5 series
 - Open collector: Photocoupler input current of 7 to 15 mA
 - Line driver: Applicable line driver AM26LS31A or equivalent

● Analog input

This is input when you issue a speed command, a torque command or a speed limit, or command a torque limit by means of analog voltage.

For analog inputs, their functions are switched according to a target control mode and parameter settings, so check the details before setup.

G series					G5 series				
Terminal	No.	Symbol	Control mode	Name	Terminal	No.	Symbol	Control mode	Name
CN1	14	-	Position	(Disabled)	CN1	14	-	Position	(Disabled)
		REF	Speed	Speed Command Input			REF	Speed	Speed command input
		TREF1	Torque	Torque Command Input*1			TREF1	Torque	Torque command input 1*1
		VLIM	Torque	Speed Limit Input*1			VLIM	Torque	Speed limit input*1
	15	AGND	-	Analog Input Ground		15	AGND1	-	Analog ground 1
		PCL	Position	Forward Torque Limit Input*2			PCL	Position	Forward torque limit input*2
	16	PCL	Speed	Forward Torque Limit Input*2		16	PCL	Speed	Forward torque limit input*2
		TREF2	Torque	Torque Command Input*1			TREF2	Torque	Torque command input 2*1
	17	AGND	-	Analog Input Ground		17	AGND1	-	Analog input ground 1
		NCL	Position	Reverse Torque Limit Input*2			NCL	Position	Reverse torque limit input*2
		NCL	Speed	Reverse Torque Limit Input*2			NCL	Speed	Reverse torque limit input*2
		-	Torque	(Disabled)			-	Torque	(Disabled)

*1. It operates as a torque command input when **Torque Command/Speed Limit Selection** (Pn5B/Pn317) is its default setting **0**: Torque command: CN1-14 pin, Speed limit: **No. 4 Internally Set Speed** (Pn56), **Speed Limit Value Setting** (Pn321).

It operates as a speed limit input when you set **1**: Torque command: CN1-16 pin, Speed limit: CN1-14 pin.

However, if you set **5**: *Mode 1: Speed control, Mode 2: Torque control* at **Control Mode Selection** (Pn02/Pn001), it will always operate as Torque command: CN1-16 pin, Speed limit: CN1-14 pin, regardless of the setting of Pn5B/Pn317.

*2. It will be enabled when you set **0**: Analog torque limit inputs from PCL and NCL at **Torque Limit Selection** (Pn03/Pn521).

The default setting is disabled at **1**: **No. 1 Torque Limit** (Pn5E/Pn013) is the limit value for both forward and reverse directions.

[Electrical specifications]

● G series

- Speed command and speed limit: The default setting of **Speed Command Scale** (Pn50) is **300 (r/min)/V** (3,000 r/min for an input of 10 V).
- Torque command and torque limit: The default setting of **Torque Command Scale** (Pn5C) is **3.0 V/100%** (Servomotor rated current for an input of 3 V).

● G5 series:

- Speed command and speed limit: The default setting of **Speed Command Scale** (Pn302) is **500 (r/min)/V** (5,000 r/min for an input of 10 V).
- Torque command and torque limit: The default setting of **Torque Command Scale** (Pn319) is **3.0 V/100%** (Servomotor rated current for an input of 3 V).

● Control input

The input functions of the G5 series can be changed by using **Input Signal Selection 1** (Pn400) to **10** (Pn409). According to the input functions that are used in the G series, change the input functions of the G5 series.

G series					G5 series				
Terminal	No.	Symbol	Control mode	Name	Terminal	No.	Symbol	Control mode	Name
CN1	7	+24VIN	-	12 to 24-VDC Power Supply Input	CN1	7	+24VIN	-	12 to 24-VDC power supply input
	8	NOT	Total control	Reverse Drive Prohibit Input		8	NOT	Total control	Reverse drive prohibition input
	9	POT	Total control	Forward Drive Prohibit Input		9	POT	Total control	Forward drive prohibition input
	26	DFSEL	Position	Vibration Filter Switch		26	DFSEL1	Position	Damping filter switching 1
		-	Speed	(Disabled)*1			VZERO	Speed	Zero Speed Designation Input
		-	Torque	(Disabled)*1			VZERO	Torque	Zero speed designation input
	27	GSEL	Total control	Gain Switch*2		27	GSEL	Total control	Gain switching
	28	GESEL	Position	Electronic Gear Switch		28	GESEL1	Position	Electronic gear switching 1
		VSEL3	Speed	Internally Set Speed Selection 3			VSEL3	Speed	Internally set speed selection 3
		-	Torque	(Disabled)			-	Torque	(Disabled)
	29	RUN	Total control	RUN Command		29	RUN	Total control	Operation command input
	30	ECRST	Position	Deviation Counter Reset Input		30	ECRST	Position	Error counter reset input
		VSEL2	Speed	Internally Set Speed Selection 2			VSEL2	Speed	Internally set speed selection 2
		-	Torque	(Disabled)			-	Torque	(Disabled)
	31	RESET	Total control	Alarm Reset Input		31	RESET	Total control	Alarm reset input
32	TVSEL	Total control	Control Mode Switch Input	32	TVSEL	Total control	Control mode switching input		
33	IPG	Position	Pulse Prohibit Input	33	IPG	Position	Pulse prohibition input		
	VSEL1	Speed	Internally Set Speed Selection 1		VSEL1	Speed	Internally set speed selection 1		
	-	Torque	(Disabled)		-	Torque	(Disabled)		

*1. The default setting of **Zero Speed Designation/Speed Command Direction Switch** (Pn06) is **0: Disabled**.

When you set **1: Zero Speed Designation Input (VZERO) enabled**, it operates as the Zero Speed Designation Input (VZERO) during speed control or in torque control.

When you set **2: Speed Command Rotation Direction Switch (PNSEL) enabled**, it operates as the Speed Command Rotation Direction Switch (PNSEL) in speed control, and it is disabled during torque control.

*2. When you set **3: Torque Limit Switch Input (TLSEL) to Torque Limit Selection** (Pn03), it operates as the Torque Limit Switch Input (TLSEL) during total control.

[Electrical specifications]

- In both the G and the G5 series
 - 12 to 24-VDC power supply input: 12 VDC-5% to 24 VDC+5%
 - Control input: ON level: 10 V or more, OFF level: 3 V or less (input current: 10 mA max.)

● Control output

The G5 series has four control outputs, less than the six control outputs of the G series by two.

Therefore, for the G5 series, narrow down the control outputs required for applications to three, except for *Servo alarm*.

G series					G5 series				
Terminal	No.	Symbol	Control mode	Name	Terminal	No.	Symbol	Control mode	Name
CN1	11	BKIR	Total control	Brake Interlock Output	CN1	11	BKIR	Total control	Brake interlock output*3
	10	BKIRCOM				10	BKIRCOM		
	35	READY	Total control	Servo Ready Output		35	READY	Total control	Servo ready completed*4
	34	READYCOM				34	READYCOM		
	37	/ALM	Total control	Alarm Output		37	/ALM	Total control	Servo alarm
	36	ALMCOM				36	ALMCOM		
	39	INP	Position	Positioning Completed Output		39	INP1	Position	Positioning completion output 1*5
		TGON	Speed	Servomotor Rotation Speed Detection Output			TGON	Speed	Motor rotation speed detection output*5
		TGON	Torque	Servomotor Rotation Speed Detection Output			TGON	Torque	Motor rotation speed detection output*5
	38	INPCOM	Position	Positioning Completed Output Common		38	INP1COM	Position	Positioning completion output 1 common
		TGONCOM	Speed	Servomotor Rotation Speed Detection Output Common			TGONCOM	Speed	Motor rotation speed detection output common
		TGONCOM	Torque	Servomotor Rotation Speed Detection Output Common			TGONCOM	Torque	Motor rotation speed detection output common
	12	OUTM1	Total control	General-purpose Output 1*1		-	-	-	No corresponding output.
	40	OUTM2	Total control	General-purpose Output 2*2		-	-	-	
41	COM		General-purpose Output Common	-	-	-			

*1. For General-purpose Output 1, set a function to output by using **General-purpose Output 1 Selection (Pn0A)**. The default setting is *1: Zero speed detection output*.

*2. For General-purpose Output 2, set a function to output by using **General-purpose Output 2 Selection (Pn09)**. The default setting is *0: Output during torque limit*.

*3. Set a function to output by using **Output Signal Selection 1 (Pn410)**. The default setting is *Brake interlock output*.

*4. Set a function to output by using **Output Signal Selection 2 (Pn411)**. The default setting is *Servo ready completed*.

*5. Set a function to output by using **Output Signal Selection 4 (Pn413)**. The default setting is *Positioning completion output 1/Motor rotation speed detection output*.

[Electrical specifications]

- In both the G and the G5 series
 - Control output: Maximum service voltage: 30 VDC, Maximum output current: 50 mA

● Absolute (absolute value) encoder input and encoder output

Using an absolute (absolute value) encoder will require the following encoder input and output wiring.

Also, using an incremental encoder will require encoder output wiring if you convey the encoder information to the host controller.

G series					G5 series				
Terminal	No.	Symbol	Name		Terminal	No.	Symbol	Name	
CN1	20	SEN	Sensor ON Input		CN1	20	SEN	Sensor ON input	
	13	SENGND				13	SENGND		
	42	BAT	Backup Battery Input			42	BAT	Backup battery input	
	43	BATGND				43	BATGND		
	21	+A	Encoder Phase-A + Output			21	+A	Encoder phase A +output	
	22	-A	Encoder Phase-A - Output			22	-A	Encoder phase A -output	
	49	+B	Encoder Phase-B + Output			49	+B	Encoder phase B +output	
	48	-B	Encoder Phase-B - Output			48	-B	Encoder phase B -output	
	23	+Z	Encoder Phase-Z + Output			23	+Z	Encoder phase Z +output	
	24	-Z	Encoder Phase-Z - Output			24	-Z	Encoder phase Z -output	
	19	Z	Phase-Z Output*1			19	Z	Encoder phase-Z output*1	
	25	ZCOM	(Open collector output)			25	ZGND	(Open collector output)	

*1. The common terminals (GND/ZGND) of Phase-Z Output (Z) and Encoder phase-Z output (Z) are the grounds common to all encoder outputs.

[Electrical specifications]

- G series
 - Sensor ON input: ON level: 4 V or more, OFF level: 0.8 V or less (input current: approx. 1 mA)
 - Backup battery input: R88A-BAT01G (TOSHIBA ER6V, voltage: 3.6 VDC, current capacity: 2,000 mA·h) connected
 - Encoder phase-A/B/Z output: Line driver AM26C31 or equivalent
 - Open collector output: Maximum service voltage: 30 VDC, Maximum output current: 50 mA

- G5 series
 - Sensor ON input: ON level: 2.0 V or more, OFF level: 0.8 V or less (input current: approx. 1 mA)
 - Backup battery input: R88A-BAT01G (TOSHIBA ER6V, voltage: 3.6 VDC, current capacity: 2,000 mA•h) connected
 - Encoder phase-A/B/Z output: Line driver AM26C31 or equivalent
 - Open collector output: Maximum service voltage: 30 VDC, Maximum output current: 50 mA

■ Encoder connector

The encoder connectors of the G series and the G5 series are the same in wiring.

G series				G5 series			
Terminal	No.	Symbol	Name	Terminal	No.	Symbol	Name
CN2	1	E5V	Encoder power supply +5 V	CN2	1	E5V	Encoder power supply +5 V
	2	E0V	Encoder power supply GND		2	E0V	Encoder power supply GND
	3	BAT+	Battery +		3	BAT+	Battery +
	4	BAT-	Battery -		4	BAT-	Battery -
	5	PS+	Encoder + phase S input		5	PS+	Encoder + phase S input
	6	PS-	Encoder - phase S input		6	PS-	Encoder - phase S input
	Shell	FG	Shield ground		Shell	FG	Frame ground

■ Analog monitor output terminal and connector

Although the G series uses check pins, the G5 series uses connectors instead.

G series				G5 series			
Terminal	No.	Symbol	Name	Terminal	No.	Symbol	Name
CP	-	IM	Analog monitor 1 check pin	CN5	1	AM1	Analog monitor output 1
	-	SP	Analog monitor 2 check pin		2	AM2	Analog monitor output 2
	-	G	Check pin ground		3	GND	Analog monitor ground
					4	-	Do not connect.
			5		-		
			6		-		

[Electrical specifications]

- G series
 - Analog monitor 1: Set by using **IM Selection** (Pn08).
 - Analog monitor 2: Set by using **SP Selection** (Pn07).
- G5 series:
 - Analog monitor output 1: Set by using **Analog Monitor 1 Selection** (Pn416) and **Analog Monitor 1 Scale Setting** (Pn417).
 - Analog monitor output 2: Set by using **Analog Monitor 2 Selection** (Pn418) and **Analog Monitor 2 Scale Setting** (Pn419).

■ Communications-related connector

The G5 series does not support the RS-485 communications, RS-232 communications, and Parameter Unit functions of the G series.

For the G5 series, parameters can be set from CX-Drive (computer tool) via USB communications.

G series				G5 series							
Terminal	No.	Symbol	Name	Terminal	No.	Symbol	Name				
CN3A	4	GND	Ground								
	7	B+	RS-485 communications data								
	8	A-									
CN3B	3	TXD	RS-232 send data								
	4	GND	Ground								
	5	RXD	RS-232 receive data								
	7	B+	RS-485 communications data								
	8	A-									
				CN7	1	VBUS	USB signal terminal				
					2	D-					
					3	D+					
					4	-	Do not connect.				
					5	GND	Signal ground				

■ Safety connector

The G5 series supports the Safe Torque OFF (STO) function of the safety standards.

At the time of replacement from the G series, consider this function if you also wish to improve safety in the device.

G series				G5 series			
Terminal	No.	Symbol	Name	Terminal	No.	Symbol	Name
				CN8	1	-	Do not connect.
					2	-	
					3	SF1-	Safety Input 1
					4	SF1+	
					5	SF2-	Safety Input 2
					6	SF2+	
					7	EDM-	EDM output
					8	EDM+	
				Shell	FG	Frame ground	

[Electrical specifications]

- G5 series
 - Safety Input External Power Supply: 12 VDC-5% to 24 VDC+5%
 - Safety input: ON level: 10 V or more, OFF level: 3 V or less
 - EDM output: Maximum service voltage: 30 VDC, Maximum output current: 50 mA

7. Gain Adjustment Methods

7.1. Gain Adjustment Method (Auto Tuning)

Using CX-Drive (computer tool) allows auto tuning of the G5 series to be executed. Auto tuning of the G5 series is described below, so execute auto tuning of the replaced device.

■ Starting *Auto Tune Wizard of G5 series*

Double-click Auto Tune from the tuning function in the workspace of CX-Drive (computer tool) to start the auto tuning wizard.

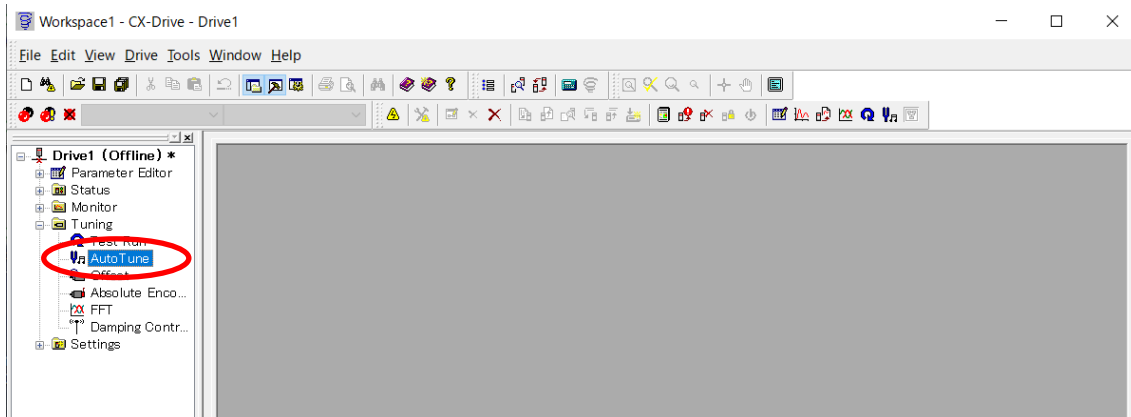

■ Selecting *1: Tuning Type of G5 series*

When the auto tuning wizard is started, *1: Tuning Type* is displayed, then select one of the three tuning modes. Choose *Automatic Auto Tune (Easy)*, and click *Next*.

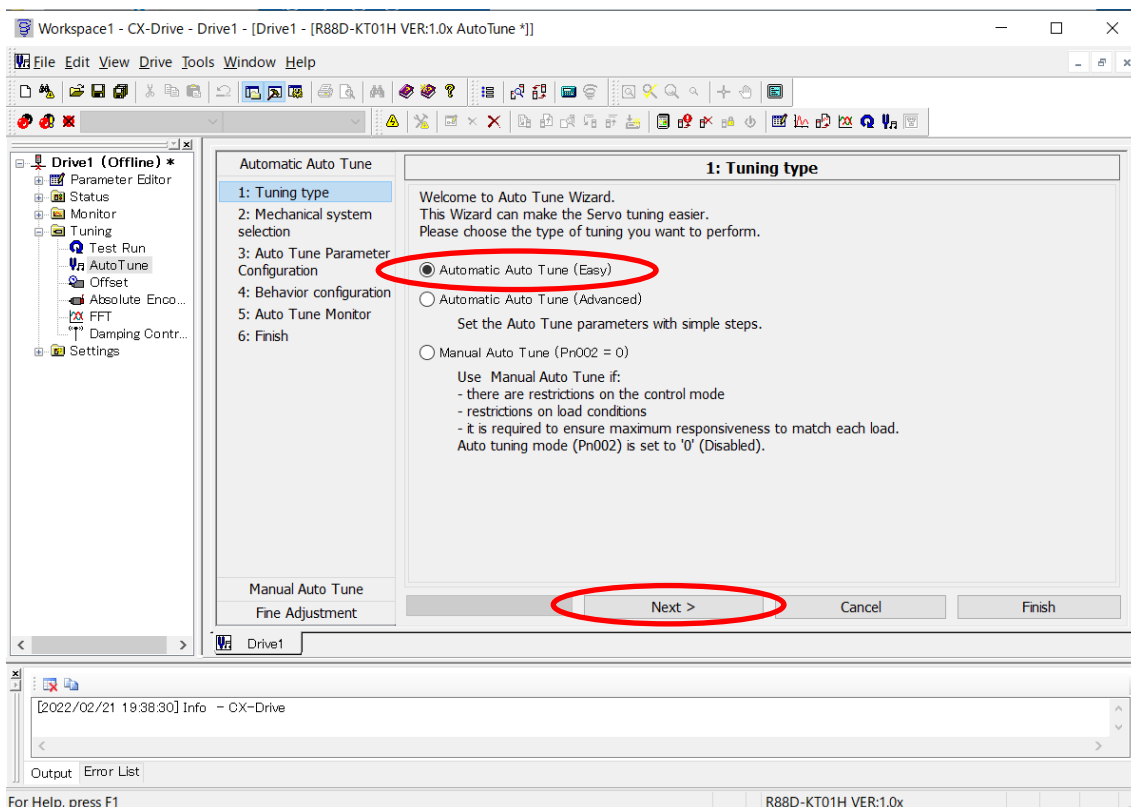

■ 2: Mechanical system selection of G5 series

Select a machine configuration of the motor to execute auto tuning for, and click Next.

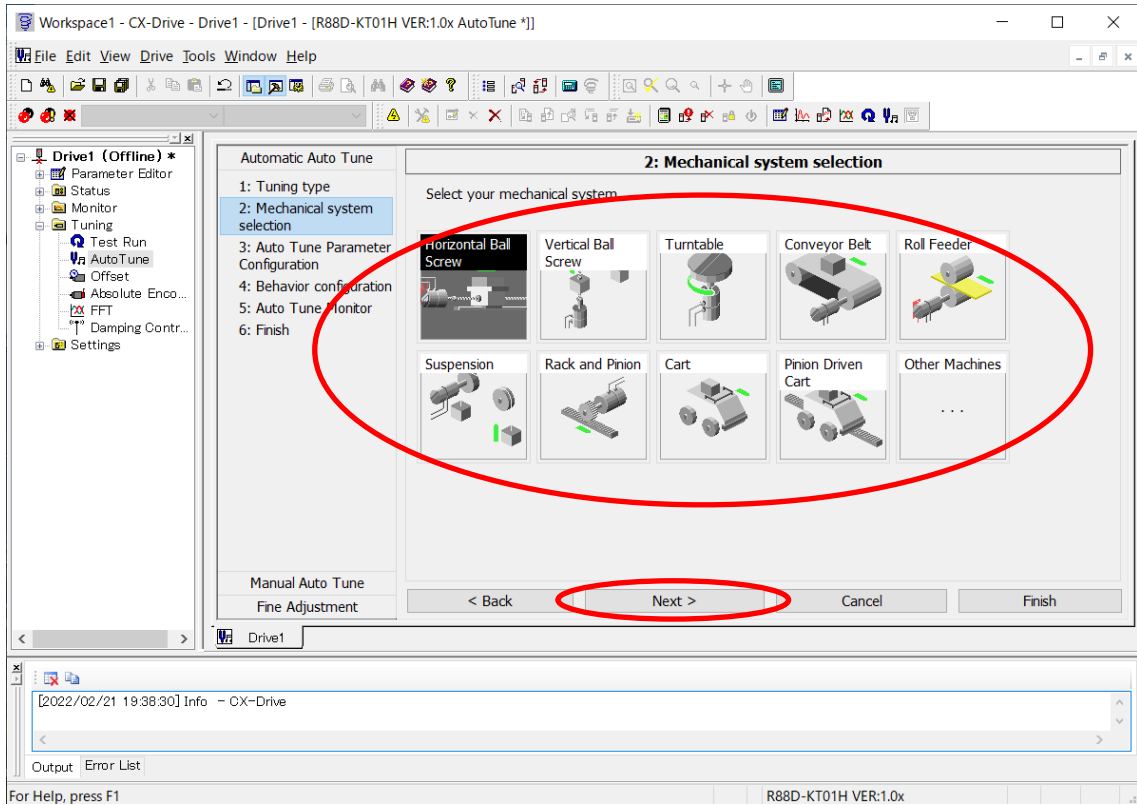

■ 3: Auto Tune Parameter Configuration of G5 series

Set the machine rigidity of the motor to execute auto tuning for.

When the coupling rigidity from the motor shaft to the load end is high and low, increase and decrease the value respectively. If you cannot judge that, set a default value of the selected machine configuration (12 in the following example), and click Next.

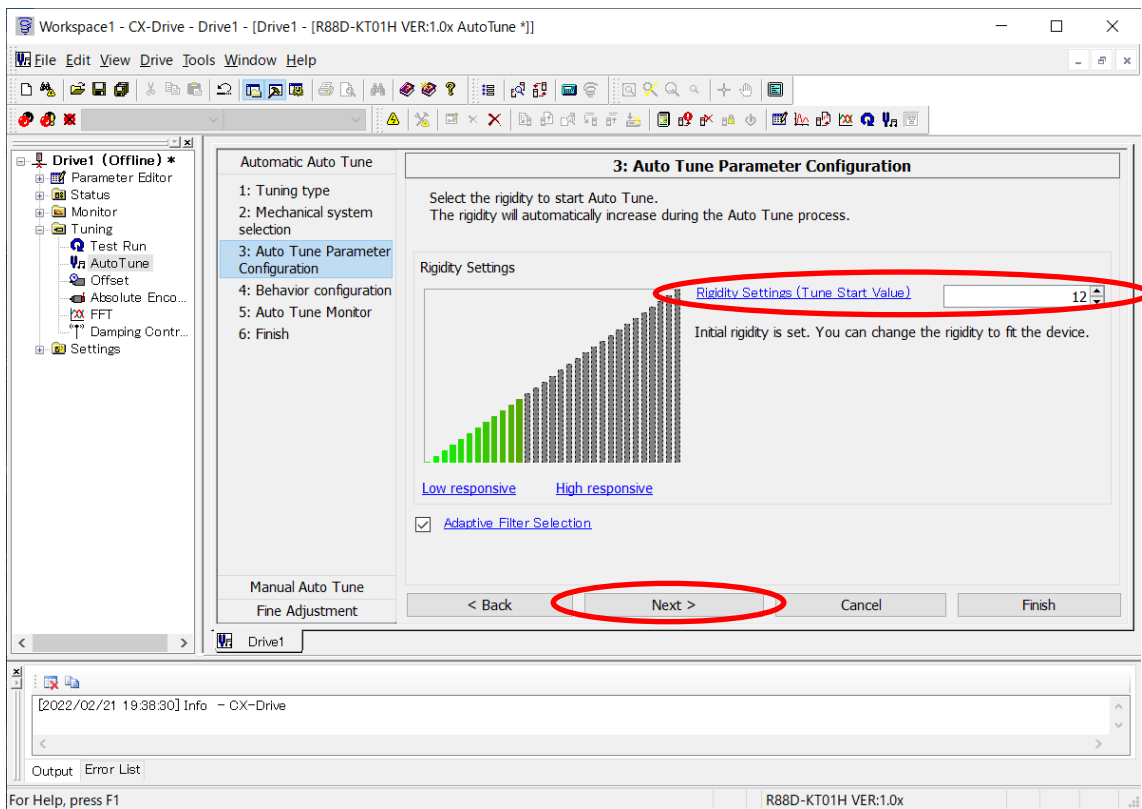

■ 4: Behavior configuration of G5 series

Fill in the Auto Tune Configuration, Motion Profile Generator, and Criteria for finishing Auto Tune fields of auto tuning, and click *Next*.

- Auto Tune Configuration
 - Set the number of times in Number of tuning iterations.
 - Set the time of one tuning in Duration of a tuning iteration.
 - * Start tuning with default values; if the tuning was inadequate, set enough number and time.
- Motion Profile Generator

Select one of the following two commands for operation to execute auto tuning.

 - The Motion Controller will perform the motion profile: Issues commands from the drive controlling controller to execute auto tuning.
 - CX-Drive (and not the motion controller) will perform the motion profile: The operation is commanded by CX-Drive.
 - * As the JOG commands of CX-Drive, set Operation (operation method), Step distance, Step Jog Speed, and Acceleration/Deceleration Time of the motor.
- Criteria for finishing Auto Tune

Set the positioning stabilization time when auto tuning is completed.

As the conditions for that motion, set *Overshoot level*, *Torque vibration level*, and *Positioning Completion Range 1*.

 - * Auto tuning may not be completed depending on the setting of *Stabilization time* or *Positioning Completion Range 1*. In that case, increase one of the settings, and execute it again.
 - * Auto tuning may not be completed if *Overshoot level* is set too low.
 - * Detecting a vibration of *Torque vibration level* results in a stop. In that case, increase the setting, and execute it again. Alternatively, enable adaptive filters, or read vibration frequencies from torque waveforms and set these frequencies to notch filters to reduce the gains of vibration generating frequencies, and then execute it again.

G5 series			Remarks
Parameter No. [dec]	Parameter name	Default setting [dec]	
Pn200	Adaptive Filter Selection	0	To enable adaptive filters, set 2: <u>Two adaptive filters enabled (3rd and 4th notch filters used).</u>
Pn201	Notch 1 Frequency Setting	5,000 Hz	To use notch filters, set vibrating frequencies to Notch 1 Frequency Setting/Notch 2 Frequency Setting (Pn201/Pn204).
Pn204	Notch 2 Frequency Setting		

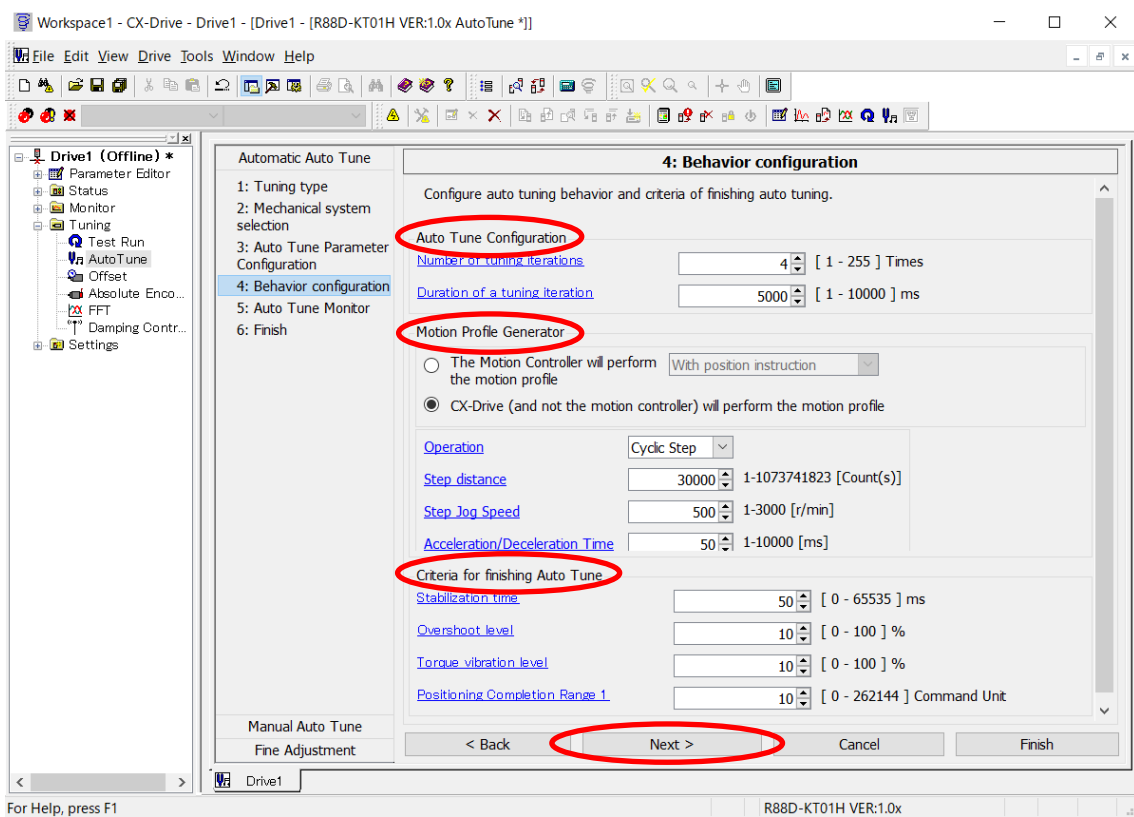

■ 5: Auto Tune Monitor of G5 series

Pressing the *Start* button starts auto tuning. To abort auto tuning, press the *Stop* button.

To check operation waveforms after auto tuning is completed, put a check mark in *View Auto Tune results with data trace*, and then start auto tuning.

When auto tuning is completed, click *Finish*.

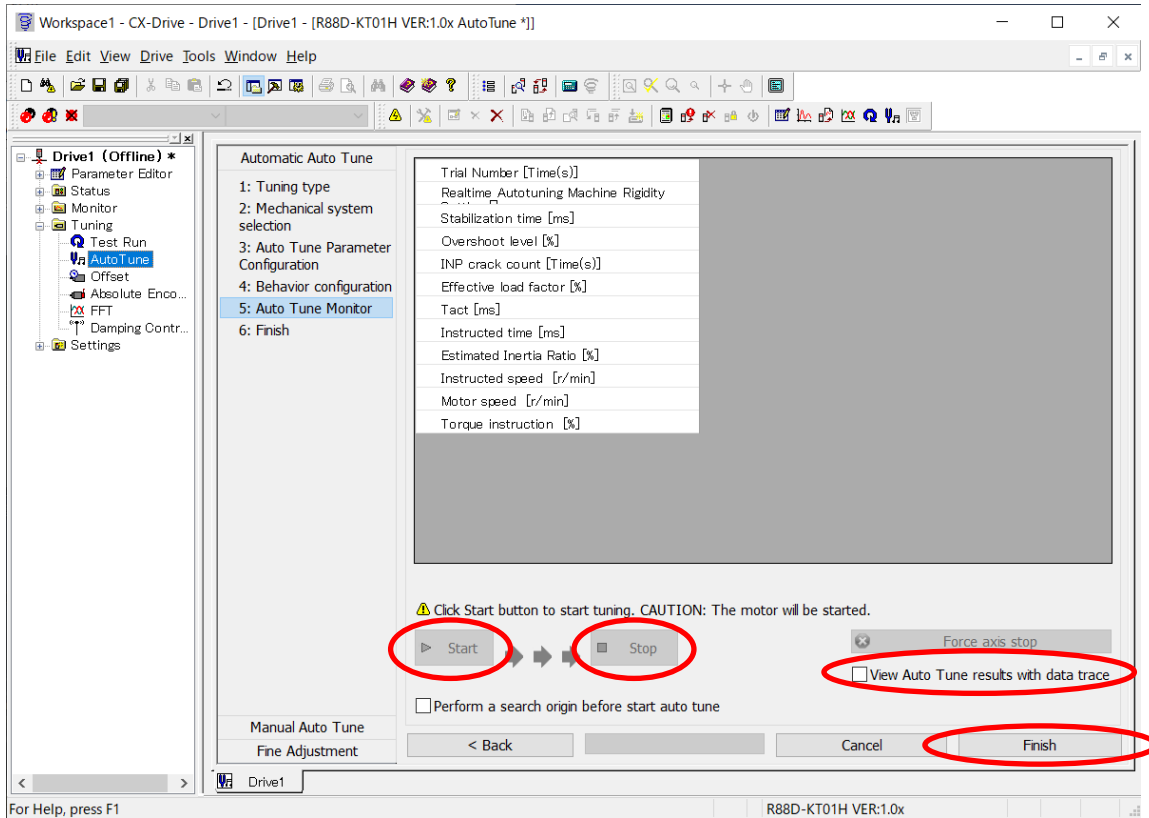

- * If you perform auto tuning with rapid acceleration/deceleration applied to operation commands, Error counter overflow (Alarm No. 24) may be detected. In that case, increase the set value of **Error Counter Overflow Level** (Pn014) temporarily, and execute auto tuning again. After auto tuning is finished, put the **Error Counter Overflow Level** (Pn014) setting back to the original set value, or set it to a proper value again.

G5 series			Remarks
Parameter No. [dec]	Parameter name	Default setting [dec]	
Pn014	Error Counter Overflow Level	100,000 Command unit	Set the detection level of Error counter overflow (Alarm No. 24). For the G5 series, the command unit (command pulse unit) is used in setting. * The setting unit of the G5 series can be changed to 1: <i>Encoder units (external scale units)</i> by using Position Setting Unit Selection (Pn520).

6: Finish of G5 series

A list of parameter values set as the results of auto tuning is displayed. Check the tuning results of the parameters. For the G5 series, the auto tuning results of gain-related parameters are saved automatically to the non-volatile memory of the drive; however, click *Save to EEPROM* so as to save all the related parameters to the non-volatile memory. Clicking *Finish* will finish the auto tuning wizard.

Workspace1 - CX-Drive - Drive1 - [Drive1 - [R88D-KT01H VER:1.0x AutoTune *]]

File Edit View Drive Tools Window Help

Drive1 (Offline) *

- Parameter Editor
- Status
- Monitor
- Tuning
 - Test Run
 - AutoTune
 - Offset
 - Absolute Enco...
 - FFT
 - Damping Contr...
- Settings

Automatic Auto Tune

1: Tuning type
2: Mechanical system selection
3: Auto Tune Parameter Configuration
4: Behavior configuration
5: Auto Tune Monitor
6: Finish

6: Finish

Finished parameter tuning. Please select Save to EEPROM to save parameters or Fine Adjustment to adjust manually.

Parameters changed

Index	Description	Value	Drive Value	Default	Range
Pn003	Realtime Autotuning Machi...	12	---	13	0 to
Pn100	Position Loop Gain 1	39.0	---	48.0	0.0 t
Pn101	Speed Loop Gain 1	22.0	---	27.0	0.1 t
Pn102	Speed Loop Integration Ti...	25.0	---	21.0	0.1 t
Pn104	Torque Command Filter Ti...	1.03	---	0.84	0.00
Pn105	Position Loop Gain 2	46.0	---	57.0	0.0 t
Pn106	Speed Loop Gain 2	22.0	---	27.0	0.1 t
Pn109	Torque Command Filter Ti...	1.03	---	0.84	0.00
Pn200	Adaptive Filter Selection	2: Two adaptive...	---	0	0 to
Pn631	Realtime Autotuning Estima...	3: Time constan...	---	1	0 to

Finish
After the Auto Tune process is completed you need to save the results to the EEPROM of the drive in order to make them effective.

Fine Adjustment
Are the results satisfactory ? If not, please use the Fine Adjustment function.

Save to EEPROM

Fine Adjustment

< Back

Cancel

Finish

For Help, press F1

R88D-KT01H VER:1.0x

7.2. Using Gain Adjustment Values for G Series as Those for G5 Series

It is possible to modify the gain adjustment values for G series that had been used, so as to use them as those for G5 series. The following table shows the four basic parameters related to gain adjustment.

According to *G to G5 settings*, modify the gain adjustment values for G series into those for G5 series.

* The G5 series has higher control performance, so it provides higher-speed and higher-precision operation as compared with the G series.

If possible, you are recommended to use the auto tuning function to set them again, after replacement with the G5 series.

G series			G5 series			G to G5 settings
Parameter No. [hex]	Parameter name	Default setting [dec]	Parameter No. [dec]	Parameter name	Default setting [dec]	
Pn10	Position Loop Gain	40 s ⁻¹	Pn100	Position Loop Gain	48.0/32.0 s ^{-1*1}	Set the proportional gain of position control. In setting, pay attention to the units, 1 s ⁻¹ for the G series and 0.1 s ⁻¹ for the G5 series.
Pn11	Speed Loop Gain	50 Hz	Pn101	Speed Loop Gain	27.0/18.0 Hz*1	Set the proportional gain of speed control. In setting, pay attention to the units, 1 Hz for the G series and 0.1 Hz for the G5 series.
Pn12	Speed Loop Integration Time Constant	20 ms	Pn102	Speed Loop Integral Time Constant	21.0/31.0 ms*1	Set the integration time constant of speed control. In setting, pay attention to the units, 1 ms for the G series and 0.1 ms for the G5 series.
Pn14	Torque Command Filter Time Constant	0.80 ms	Pn104	Torque Command Filter Time Constant	0.84/1.26 ms*1	Set the torque command filter time constant of torque control. Set the value as it is, because the unit remains unchanged.

*1. For the numerical notation sv/SV, sv represents the setting for less than 1 kW drives of 100 V or 200 V type, and SV represents the setting for other drives.

8. Connecting with Host Controllers

Methods for connecting with host controllers vary with the types of host controllers. These are described below separately for the host controllers of pulse output type and those of analog output type.

8.1. For Host Controllers of Pulse Output Type

Example: Position Control Unit (for CJ Series) Such as CJ1W-NC□□3

The G series and the G5 series are different in encoder resolution of the motor. Therefore, if it is made to operate as it is in the G5 series after replacement, positioning may be carried out differently. As shown below, use the electronic gear functions to correct the encoder resolution. The following settings will remove the influence on the host controller side and allow you to use the settings and programs of the host controller without having to change them.

G series			G5 series		
Parameter No. [hex]	Parameter name	Default setting [dec]	Parameter No. [dec]	Parameter name	Default setting [dec]
Pn48	Electronic Gear Ratio Numerator 1	0	Pn008	Electronic Gear Integer Setting	10,000
Pn49	Electronic Gear Ratio Numerator 2	0	Pn009	Electronic Gear Ratio Numerator 1	0
Pn4A	Electronic Gear Ratio Numerator Exponent	0	Pn500	Electronic Gear Ratio Numerator 2	0
Pn4B	Electronic Gear Ratio Denominator	10,000	-	-	-
			Pn010	Electronic Gear Ratio Denominator	10,000

■ When electronic gear functions (Pn48 to Pn4B) of G series are default settings

The G series and the G5 series have the same default setting, 10,000 input pulses for one motor rotation as follows. Therefore, the G5 series after replacement can execute the same positioning without problems.

- Default settings of G series electronic gear functions
The default setting of **Electronic Gear Ratio Numerator 1/2** (Pn48/Pn49) is 0, and the encoder resolution of the motor in use will be set automatically to the electronic gear numerator. The motor is rotated once by 10,000 input pulses, which is the default setting of **Electronic Gear Ratio Denominator** (Pn4B).
- Default settings of G5 series electronic gear functions
The default setting of **Electronic Gear Integer Setting** (Pn008) is 10,000, meaning that the motor is rotated once by 10,000 input pulses.

■ When Electronic Gear Ratio Numerator 1/2 (Pn48/Pn49) of G series is 0

Set the value that is set in **Electronic Gear Ratio Denominator** (Pn4B) of G series, to **Electronic Gear Integer Setting** (Pn008) of G5 series.

- G series electronic gear functions
If 0 is set to **Electronic Gear Ratio Numerator 1/2** (Pn48/Pn49), the encoder resolution of the motor in use will be set automatically to the electronic gear numerator. The motor is rotated once by the input pulse setting of **Electronic Gear Ratio Denominator** (Pn4B).
- G5 series electronic gear functions
The motor is rotated once by the input pulse setting of **Electronic Gear Integer Setting** (Pn008).

■ When Electronic Gear Ratio Numerator 1/2 (Pn48/Pn49) of G series is ≠ 0

When **Electronic Gear Ratio Numerator 1/2** (Pn48/Pn49) is ≠ 0, set the values in which a difference in the encoder resolution of the motor is reflected.

The description is divided into two, because the resolution is different between the incremental encoder and the absolute (absolute value) encoder in both the G and the G5 series.

If the following calculation result has exceeded the parameter setting range, reduce fractions to a common denominator to convert the value into a smaller one before setting it.

(1) For the incremental encoder

Set the following values to the electronic gear functions (Pn008/Pn009/Pn500/Pn010) of the G5 series.

- **Electronic Gear Integer Setting** (Pn008) = 0
- **Electronic Gear Ratio Numerator 1/2** (Pn009/Pn500)
= **Electronic Gear Ratio Numerator 1/2** (Pn48/Pn49) of G series × 2 **Electronic Gear Ratio Numerator Exponent** (Pn4A) of G series × 1,048,576
- **Electronic Gear Ratio Denominator** (Pn010) = **Electronic Gear Ratio Denominator** (Pn4B) of G series × 10,000

(2) For the absolute (absolute value) encoder

The G series and the G5 series are the same in absolute (absolute value) encoder resolution.

Set the following values to the electronic gear functions (Pn008/Pn009/Pn500/Pn010) of the G5 series.

- **Electronic Gear Integer Setting** (Pn008) = 0
- **Electronic Gear Ratio Numerator 1/2** (Pn009/Pn500)
= **Electronic Gear Ratio Numerator 1/2** (Pn48/Pn49) of G series × 2 **Electronic Gear Ratio Numerator Exponent** (Pn4A) of G series
- **Electronic Gear Ratio Denominator** (Pn010) = **Electronic Gear Ratio Denominator** (Pn4B) of G series

8.2. For Host Controllers of Analog Output Type

Example: Motion Control Unit (for CS1 Series) Such as CS1W-MC□21-V1

The G series and the G5 series are different in encoder resolution of the motor. Therefore, if it is made to operate as it is in the G5 series after replacement, positioning may be carried out differently. As shown below, use the encoder dividing functions to correct the encoder resolution. The following settings will remove the influence on the host controller side and allow you to use the settings and programs of the host controller without having to change them.

G series			G5 series		
Parameter No. [hex]	Parameter name	Default setting [dec]	Parameter No. [dec]	Parameter name	Default setting [dec]
Pn44	Encoder Divider Numerator Setting	2,500	Pn011	Encoder Dividing Numerator	2,500
Pn45	Encoder Divider Denominator Setting	0	Pn503	Encoder Dividing Denominator	0

■ When encoder dividing functions (Pn44/Pn45) of G series are default settings

The G series and the G5 series have the same default setting, 2,500 pulses output for one motor rotation as follows. Therefore, the G5 series after replacement can execute the same positioning without problems.

- Default settings of encoder dividing functions of G and G5 series
In both the G and the G5 series, the default setting of **Encoder Divider Denominator Setting/Encoder Dividing Denominator** (Pn45/Pn503) is 0, and the encoder resolution of the motor in use will be set automatically to the encoder dividing denominator. Therefore, the default setting of **Encoder Divider Numerator Setting/Encoder Dividing Numerator** (Pn44/Pn011), 2,500 pulses, will be output for one motor rotation.

■ When Encoder Divider Denominator Setting (Pn45) of G series is 0

Set the value that is set in **Encoder Divider Numerator Setting** (Pn44) of G series, to **Encoder Dividing Numerator** (Pn011) of G5 series.

- Encoder dividing functions of G and G5 series
In both the G and the G5 series, if 0 is set to **Encoder Divider Denominator Setting/Encoder Dividing Denominator** (Pn45/Pn503), the encoder resolution of the motor in use will be set automatically to the encoder dividing denominator. Therefore, pulses set in **Encoder Divider Numerator Setting/Encoder Dividing Numerator** (Pn44/Pn011) will be output for one motor rotation.

■ When Encoder Divider Denominator Setting (Pn45) of G series is ≠ 0

When **Encoder Divider Denominator Setting** (Pn45) is ≠ 0, set the values in which a difference in the encoder resolution of the motor is reflected.

The description is divided into two, because the resolution is different between the incremental encoder and the absolute (absolute value) encoder in both the G and the G5 series.

If the following calculation result has exceeded the parameter setting range, reduce fractions to a common denominator to convert the value into a smaller one before setting it.

(1) For the incremental encoder

Set the following values to the encoder dividing functions (Pn011/Pn503) of the G5 series.

- **Encoder Dividing Numerator** (Pn011) = **Encoder Divider Numerator Setting** (Pn44) of G series × 10,000
- **Encoder Dividing Denominator** (Pn503) = **Encoder Divider Denominator Setting** (Pn45) of G series × 1,048,576

(2) For the absolute (absolute value) encoder

The G series and the G5 series are the same in absolute (absolute value) encoder resolution.

Set the following values to the encoder dividing functions (Pn011/Pn503) of the G5 series.

- **Encoder Dividing Numerator** (Pn011) = **Encoder Divider Numerator Setting** (Pn44) of G series
- **Encoder Dividing Denominator** (Pn503) = **Encoder Divider Denominator Setting** (Pn45) of G series

8.3. Transferring Absolute (Absolute Value) Encoder Data to Host Controllers Target: Position Control Unit (High-Speed Type) CJ1W-NC□□4, Motion Control Unit (for CS1 Series) CS1W-MC□21-V1

To build an absolute system with Position Control Unit (high-speed type) CJ1W-NC□□4 or Motion Control Unit (for CS1 series) CS1W-MC□21-V1, you need to transfer the absolute (absolute value) encoder data to the host controller in turning on the drive.

The G series and the G5 series are different in transfer method; therefore, in replacing with the G5 series, set up the host controller as follows.

■ For the Position Control Unit (high-speed type) CJ1W-NC□□4

Double-click CJ1W-NC□□4 (Position Control Unit) on the I/O table of CX-Programmer (computer tool) to open the following setup window of CJ1W-NC□□4 (Position Control Unit).

Choose *Axis Parameter*, and set *Parameter Type* to *All* to display all the parameters.

Set *Absolute Value(G5-Series/W-Series)* to the *Encode Type* parameter.

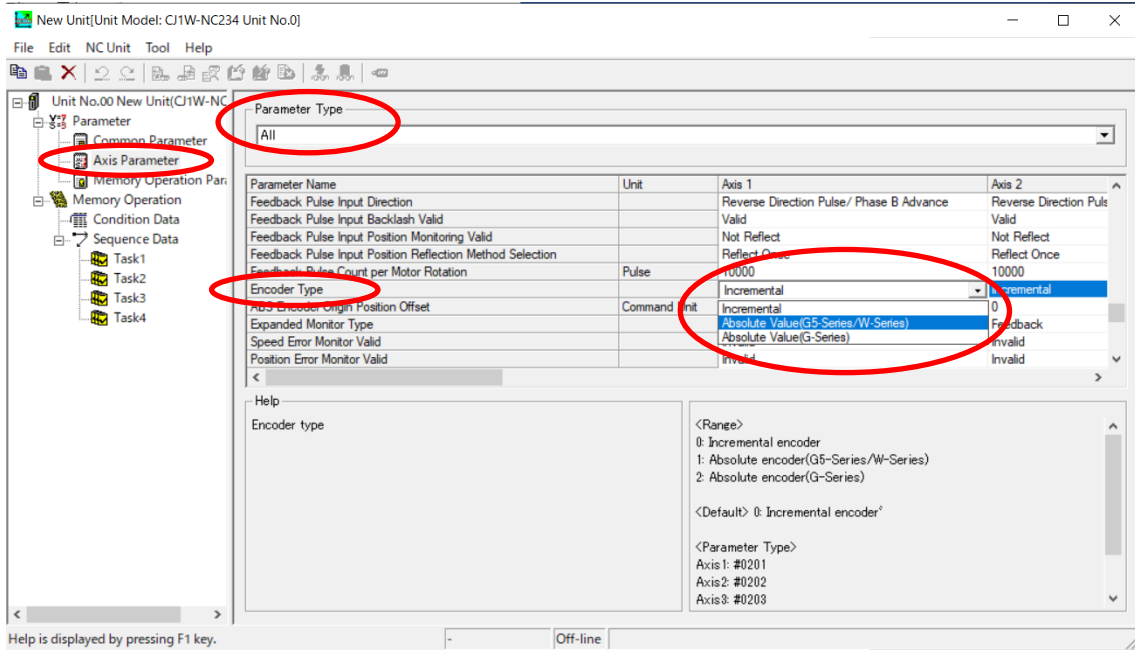

■ **For the Motion Control Unit (for CS1 Series) CS1W-MC□21-V1**

After double-clicking *Parameter Set* of the Motion Control Unit by using CX-Motion (computer tool), click the icon to open the *Machine Parameters* window.

Set *ABS(R88D-K/W/U)* to *Type* on the *Encoder* tab.

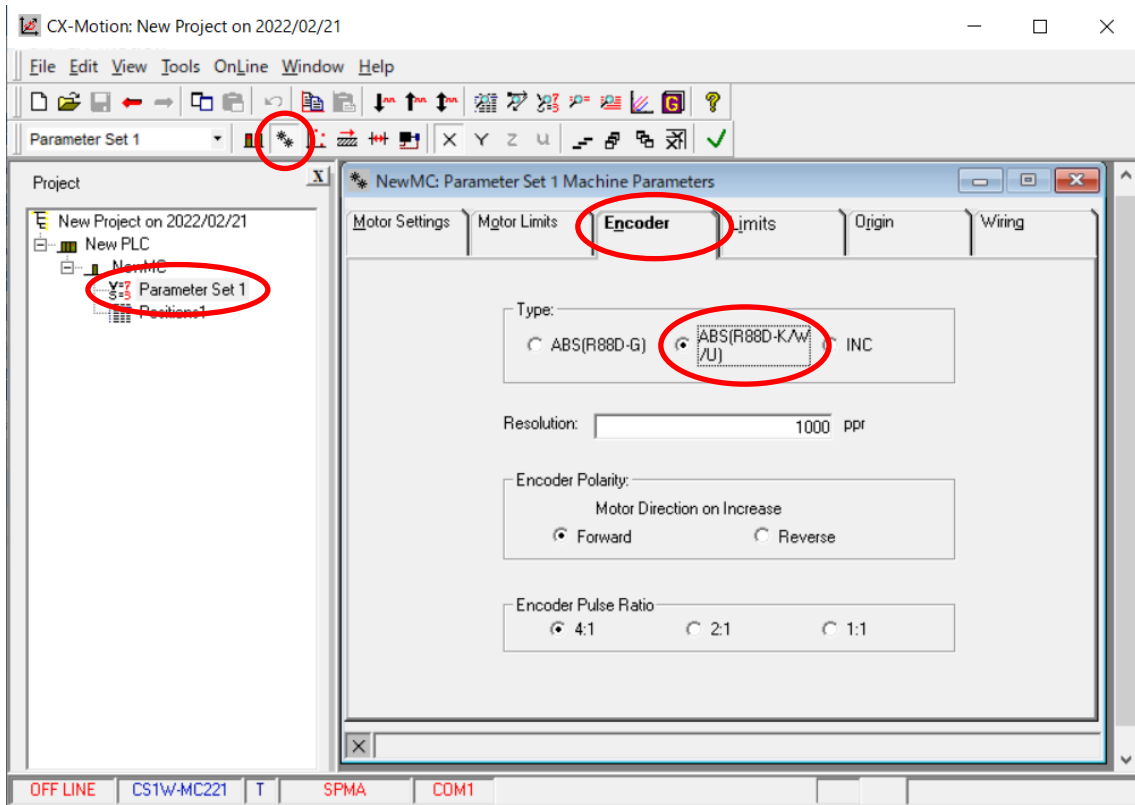

9. Detailed Comparison of Parameters

9.1. Function Selection Parameters

G series			G5 series			Remarks
Parameter No. [hex]	Parameter name	Default setting [dec]	Parameter No. [dec]	Parameter name	Default setting [dec]	
Pn00	Unit No. Setting	1	Pn531	Axis Number	1	Set the Unit No. for RS-232/485 communications. <ul style="list-style-type: none"> For the G series, use the Unit No. switch on the front panel to change the setting. For the G5 series, it is an axis number setting for USB communications. Normally, do not change the set value. * The G5 series does not have the RS-232/485 communications function.
Pn01	Default Display	1	Pn528	Default Display	1	Set the first data to be displayed on the 7-segment LED display after the power supply is turned ON. <ul style="list-style-type: none"> In both the G and the G5 series, the default setting is 1: Servomotor rotation speed.
Pn02	Control Mode Selection	0	Pn001	Control Mode Selection	0	Set the control mode to use. <ul style="list-style-type: none"> In both the G and the G5 series, the default setting is 0: Position control (pulse train command).
Pn03	Torque Limit Selection	1	Pn521	Torque Limit Selection	1	Set the method to switch the torque limits to use. <ul style="list-style-type: none"> The default setting of the G series is 1: The limit value for forward and reverse operation is No. 1 Torque Limit (Pn5E) setting. The default setting of the G5 series is 1: The limit value for forward and reverse operation is No. 1 Torque Limit (Pn013) setting.
Pn04	Drive Prohibit Input Selection	1	Pn504	Drive Prohibition Input Selection	1	Set whether to enable or disable the drive prohibition function. <ul style="list-style-type: none"> In both the G and the G5 series, the default setting is 1: Disabled.
Pn05	Command Speed Selection	0	Pn300	Command Speed Selection	0	Select a speed command for speed control. <ul style="list-style-type: none"> In both the G and the G5 series, the default setting is 0: Analog speed command input. * To use the internally set speed function, set internally set speeds.
Pn06	Zero Speed Designation/Speed Command Direction Switch	0	Pn315	Zero Speed Designation Selection	0	Use this setting to use the function of Zero Speed Designation or Speed Command Direction Switch (Speed command sign input). <ul style="list-style-type: none"> In both the G and the G5 series, the default setting is 0: Disabled. For the G series, set it up as follows. <ul style="list-style-type: none"> Zero Speed Designation: Set 1: Zero Speed Designation enabled to Zero Speed Designation/Speed Command Direction Switch (Pn06). Speed Command Direction Switch: Set 2: Speed Command Direction Switch enabled to Zero Speed Designation/Speed Command Direction Switch (Pn06). For the G5 series, make the following settings. <ul style="list-style-type: none"> Zero Speed Designation: Set 1: Zero Speed Designation enabled to Zero Speed Designation Selection (Pn315). Zero Speed Designation Input (VZERO) is assigned to the CN1-26 pin at the default setting 0091910A hex of Input Signal Selection 3 (Pn402). Speed Command Direction Switch: Set 1: Speed command sign input (VSIGN) enabled to Speed Command Direction Selection (Pn301). Set 0091120A hex to Input Signal Selection 3 (Pn402), and assign Speed command sign input (VSIGN) to the CN1-26 pin. * For the rotation direction when Speed command sign input (VSIGN) is used, the setting of Analog Speed Command Rotation Direction Switching (Pn303) is disabled, and the forward direction is fixed at the time of opening.
			Pn301	Speed Command Direction Selection	0	
			Pn402	Input Signal Selection 3	0091910A hex	
			Pn303	Analog Speed Command Rotation Direction Switching	1	

G series			G5 series			Remarks
Parameter No. [hex]	Parameter name	Default setting [dec]	Parameter No. [dec]	Parameter name	Default setting [dec]	
Pn07	SP Selection	3	Pn416	Analog Monitor 1 Selection	0	Set the monitor and scale to output to the SP analog output (AM1 Analog monitor output 1). <ul style="list-style-type: none"> In both the G and the G5 series, the default setting is <u>Motor speed (3,000 r/min.: 6 V)</u>. For the G series, use SP Selection (Pn07) to set both a monitor and a scale. For the G5 series, use Analog Monitor 1 Selection (Pn416) to select a monitor, and use Analog Monitor 1 Scale Setting (Pn417) to set a scale.
			Pn417	Analog Monitor 1 Scale Setting	0	
Pn08	IM Selection	0	Pn418	Analog Monitor 2 Selection	4	Set the monitor and scale to output to the IM analog output (AM2 Analog monitor output 2). <ul style="list-style-type: none"> In both the G and the G5 series, the default setting is <u>Torque command (100% of rated torque: 3 V)</u>. For the G series, use IM Selection (Pn08) to set both a monitor and a scale. For the G5 series, use Analog Monitor 2 Selection (Pn418) to select a monitor, and use Analog Monitor 2 Scale Setting (Pn419) to set a scale.
			Pn419	Analog Monitor 2 Scale Setting	0	
Pn09	General-purpose Output 2 Selection	0	Pn411	Output Signal Selection 2	00020202 hex	Set functions to output from the general-purpose outputs 1 and 2. <ul style="list-style-type: none"> The G and the G5 series are different in the number of output terminals as follows. Use the general-purpose output settings to make adjustments. <ul style="list-style-type: none"> G series: 2 points, general-purpose outputs 1 and 2, out of 6 outputs in total G5 series: 3 points, general-purpose outputs 1, 2, and 4, out of 4 outputs in total The default settings of the G series are as follows. <ul style="list-style-type: none"> General-purpose output 1: Zero speed detection output General-purpose output 2: Output during torque limit The default settings of the G5 series are as follows. <ul style="list-style-type: none"> General-purpose output 1: Brake interlock output General-purpose output 2: Servo ready completed output General-purpose output 4: Positioning completion output (For speed control or torque control: Motor rotation speed detection output) * For the G5 series, you can set functions by position control, speed control, or torque control.
Pn0A	General-purpose Output 1 Selection	1	Pn410	Output Signal Selection 1	00030303 hex	
			Pn413	Output Signal Selection 4	00050504 hex	
Pn0B	Operation Switch when Using Absolute Encoder	0	Pn015	Operation Switch when Using Absolute Encoder	1	Set the usage of the absolute encoder. <ul style="list-style-type: none"> The default setting of the G series is <i>0: Use as absolute encoder</i>. The default setting of the G5 series is <i>1: Use as incremental encoder</i>. * To use an absolute encoder, after connecting a battery for backups, configure the absolute encoder, and perform the Absolute Encoder Setup.
Pn0C	RS-232 Baud Rate Setting	2	-	-	-	Set the baud rate for RS-232 communications. <ul style="list-style-type: none"> The default setting of the G series is <i>2: 9,600 bps</i>. The G5 series does not have the RS-232 communications function.

G series			G5 series			Remarks
Parameter No. [hex]	Parameter name	Default setting [dec]	Parameter No. [dec]	Parameter name	Default setting [dec]	
Pn0D	RS-485 Baud Rate Setting	2	-	-	-	Set the baud rate for RS-485 communications. <ul style="list-style-type: none"> • The default setting of the G series is 2: 9,600 bps. • The G5 series does not have the RS-485 communications function.
Pn0E	Front Key Protection Setting	0	Pn535	Front Key Protection Setting	0	Impose limitations on key operations on the front panel. <ul style="list-style-type: none"> • In both the G and the G5 series, the default setting is 0: <i>Not protected</i>.
Pn0F	Reserved	-	-	-	-	-

9.2. Parameters Related to Gain

G series			G5 series			Remarks
Parameter No. [hex]	Parameter name	Default setting [dec]	Parameter No. [dec]	Parameter name	Default setting [dec]	
Pn10	Position Loop Gain	40 s ⁻¹	Pn100	Position Loop Gain	48.0/ 32.0 s ^{-1*1}	Set the proportional gain of position control. <ul style="list-style-type: none"> The default setting differs between G and G5 series. In setting, pay attention to the units, 1 s⁻¹ and 0.1 s⁻¹.
Pn11	Speed Loop Gain	50 Hz	Pn101	Speed Loop Gain	27.0/ 18.0 Hz*1	Set the proportional gain of speed control. <ul style="list-style-type: none"> The default setting differs between G and G5 series. In setting, pay attention to the units, 1 Hz and 0.1 Hz.
Pn12	Speed Loop Integration Time Constant	20 ms	Pn102	Speed Loop Integral Time Constant	21.0/ 31.0 ms*1	Set the integration time constant of speed control. <ul style="list-style-type: none"> The default setting differs between G and G5 series. In setting, pay attention to the units, 1 ms and 0.1 ms.
Pn13	Speed Feedback Filter Time Constant	0	Pn103	Speed Feedback Filter Time Constant	0	Set the filter time constant in the speed detection section. <ul style="list-style-type: none"> In both the G and the G5 series, the default setting is 0 (<i>high responsiveness</i>). In both the G and the G5 series, increasing the set value can suppress vibration but will reduce responsiveness.
Pn14	Torque Command Filter Time Constant	0.80 ms	Pn104	Torque Command Filter Time Constant	0.84/ 1.26 ms*1	Set the torque command filter time constant of torque control. <ul style="list-style-type: none"> The default setting differs between G and G5 series.
Pn15	Feed-forward Amount	30.0 %	Pn110	Speed Feed-forward Amount	30.0 %	Set the feed-forward amount to be transmitted from position control to speed control. <ul style="list-style-type: none"> In both the G and the G5 series, the default setting is 30%.
Pn16	Feed-forward Command Filter	1.00 ms	Pn111	Speed Feed-forward Command Filter	0.50 ms	Set the filter time constant in the feed-forward section to be transmitted from position control to speed control. <ul style="list-style-type: none"> The default setting differs between G and G5 series.
Pn17	Reserved	-	-	-	-	-
Pn18	Position Loop Gain 2	20 s ⁻¹	Pn105	Position Loop Gain 2	57.0/ 38.0 s ^{-1*1}	Set the proportional gain of position control. <ul style="list-style-type: none"> The default setting differs between G and G5 series. In setting, pay attention to the units, 1 s⁻¹ and 0.1 s⁻¹.
Pn19	Speed Loop Gain 2	80 Hz	Pn106	Speed Loop Gain 2	27.0/ 18.0 Hz*1	Set the proportional gain of speed control. <ul style="list-style-type: none"> The default setting differs between G and G5 series. In setting, pay attention to the units, 1 Hz and 0.1 Hz.
Pn1A	Speed Loop Integration Time Constant 2	50 ms	Pn107	Speed Loop Integral Time Constant 2	1,000.0 ms	Set the integration time constant of speed control. <ul style="list-style-type: none"> The default setting differs between G and G5 series. In setting, pay attention to the units, 1 ms and 0.1 ms.
Pn1B	Speed Feedback Filter Time Constant 2	0	Pn108	Speed Feedback Filter Time Constant 2	0	Set the filter time constant in the speed detection section. <ul style="list-style-type: none"> In both the G and the G5 series, the default setting is 0 (<i>high responsiveness</i>).
Pn1C	Torque Command Filter Time Constant 2	1.00 ms	Pn109	Torque Command Filter Time Constant 2	0.84/ 1.26 ms*1	Set the torque command filter time constant of torque control. <ul style="list-style-type: none"> The default setting differs between G and G5 series.

*1. For the numerical notation sv/SV, sv represents the setting for less than 1 kW drives of 100 V or 200 V type, and SV represents the setting for other drives.

G series			G5 series			Remarks
Parameter No. [hex]	Parameter name	Default setting [dec]	Parameter No. [dec]	Parameter name	Default setting [dec]	
Pn1D	Notch Filter 1 Frequency	1,500 Hz	Pn201	Notch 1 Frequency Setting	5,000 Hz	Set the frequency of the 1st resonance suppression notch filter. <ul style="list-style-type: none"> For the default setting of the G series, the notch function is disabled at 1,500 Hz. For the default setting of the G5 series, the notch function is disabled at 5,000 Hz.
Pn1E	Notch Filter 1 Width	2	Pn202	Notch 1 Width Setting	2	Set the width of the 1st resonance suppression notch filter. <ul style="list-style-type: none"> In both the G and the G5 series, the default setting is 2. In both the G and the G5 series, increasing the set value will obtain a larger width. * For the G5 series, the notch filter depth can be set to Notch 1 Depth Setting (Pn203).
			Pn203	Notch 1 Depth Setting	0	
Pn1F	Reserved	-	-	-	-	-
Pn20	Inertia Ratio	300 %	Pn004	Inertia Ratio	250 %	Set the ratio of load inertia to the motor rotor inertia in units of %. <ul style="list-style-type: none"> For the G series, it is automatically set when you execute normal mode auto tuning. Or, it is automatically updated when you enable Realtime Autotuning Mode Selection (Pn21). For the G5 series, it is automatically updated when you enable Realtime Autotuning Mode Selection (Pn002).
Pn21	Realtime Autotuning Mode Selection	0	Pn002	Realtime Autotuning Mode Selection	1	Set the functional operation that estimates the load condition in real time and corrects the control constant. <ul style="list-style-type: none"> The default setting of the G series is <u>0: Disabled</u>. The default setting of the G5 series is <u>1: This mode focuses on stability</u>. * In replacement, set it to <u>0: Disabled</u> like the G series.
Pn22	Realtime Autotuning Machine Rigidity Selection	2	Pn003	Realtime Autotuning Machine Rigidity Setting	13/11*1	Set the rigidity of equipment for real-time auto tuning. <ul style="list-style-type: none"> The default setting differs between G and G5 series. Adjust the setting according to the rigidity of equipment.
Pn23	Adaptive Filter Selection	0	Pn200	Adaptive Filter Selection	0	Set the operation of adaptive filters. <ul style="list-style-type: none"> In both the G and the G5 series, the default setting is <u>0: Adaptive filter disabled</u>.
Pn24	Vibration Filter Selection	0	Pn213	Damping Filter Selection	0	Set the operation of damping filters. <ul style="list-style-type: none"> In both the G and the G5 series, the default setting is <u>0: Damping filters 1 and 2 can be used</u>.
Pn25	Autotuning Operation Setting	0	-	-	-	Set the operation pattern of normal mode auto tuning. <ul style="list-style-type: none"> The G5 series does not have the related parameter. * For the G5 series, execute the auto tuning with the operation pattern set, from CX-Drive (computer tool).
Pn26	Overrun Limit Setting	1.0 Rotation	Pn514	Overrun Limit Setting	1.0 Rotation	Set the allowable operating range for the position command input range. Going beyond the range causes an Overrun Limit Error (Alarm No. 34) to be detected. <ul style="list-style-type: none"> In both the G and the G5 series, the default setting is <u>1.0 rotation</u>.

*1. For the numerical notation sv/SV, sv represents the setting for less than 1 kW drives of 100 V or 200 V type, and SV represents the setting for other drives.

G series			G5 series			Remarks
Parameter No. [hex]	Parameter name	Default setting [dec]	Parameter No. [dec]	Parameter name	Default setting [dec]	
Pn27	Instantaneous Speed Observer Setting	0	Pn610	Function Expansion Setting	0	<p>Set the operation of the instantaneous speed observer.</p> <ul style="list-style-type: none"> In both the G and the G5 series, the default setting is <i>Disabled</i>. * For the G5 series, one parameter sets the following six functions. Enable or disable the functions by means of their respective bits. <ul style="list-style-type: none"> bit 0: Instantaneous speed observer function bit 1: Disturbance observer function bit 2: Disturbance observer operation setting bit 3: Inertia ratio switching function bit 4: Electric current response improvement function bit 5: Analog Torque Feed-forward
Pn28	Notch Filter 2 Frequency	1,500 Hz	Pn204	Notch 2 Frequency Setting	5,000 Hz	<p>Set the frequency of the 2nd resonance suppression notch filter.</p> <ul style="list-style-type: none"> For the default setting of the G series, the notch function is disabled at <i>1,500 Hz</i>. For the default setting of the G5 series, the notch function is disabled at <i>5,000 Hz</i>.
Pn29	Notch Filter 2 Width	2	Pn205	Notch 2 Width Setting	2	<p>Set the width of the 2nd resonance suppression notch filter.</p> <ul style="list-style-type: none"> In both the G and the G5 series, the default setting is <i>2</i>. In both the G and the G5 series, increasing the set value will obtain a larger width.
Pn2A	Notch Filter 2 Depth	0	Pn206	Notch 2 Depth Setting	0	<p>Set the depth of the 2nd resonance suppression notch filter.</p> <ul style="list-style-type: none"> In both the G and the G5 series, the default setting is <i>0</i>. In both the G and the G5 series, increasing the set value will obtain a shallower depth.
Pn2B	Vibration Frequency 1	0.0 Hz	Pn213	Damping Filter Selection	0	<p>Damping control is a function that suppresses vibration at the load end.</p> <p>Set the damping frequency of the damping filter 1.</p> <ul style="list-style-type: none"> In both the G and the G5 series, the default setting is <i>0.0 Hz</i> and the damping filter is disabled. * Setting 0.0 to 0.9 Hz disables the damping filter. For the G series, the damping filters 1 and 2 can always be used. For the G5 series, the default setting of Damping Filter Selection (Pn213) is <i>0: Damping filter 1 and 2 enabled</i>. * For the G5 series, in the setting of Damping Filter Selection (Pn213), four damping filters can be changed by rotation directions and external inputs (DFSEL1 and DFSEL2).
			Pn214	Damping Frequency 1	0.0 Hz	
Pn2C	Vibration Filter 1 Setting	0.0 Hz	Pn215	Damping Filter 1 Setting	0.0 Hz	<p>Set the vibration suppression effect of the 1st damping filter.</p> <ul style="list-style-type: none"> In both the G and the G5 series, the default setting is <i>0.0 Hz</i>. In both the G and the G5 series, increasing the value will hasten the operation of vibration suppression. Decrease the value if torque saturation occurs to prevent vibration suppression.
Pn2D	Vibration Frequency 2	0.0 Hz	Pn216	Damping Frequency 2	0.0 Hz	<p>Set the damping frequency of the damping filter 2.</p> <ul style="list-style-type: none"> In both the G and the G5 series, the default setting is <i>0.0 Hz</i> and the damping filter is disabled. * Setting 0.0 to 0.9 Hz disables the damping filter.

G series			G5 series			Remarks
Parameter No. [hex]	Parameter name	Default setting [dec]	Parameter No. [dec]	Parameter name	Default setting [dec]	
Pn2D	Vibration Frequency 2	0.0 Hz	Pn216	Damping Frequency 2	0.0 Hz	Set the damping frequency of the damping filter 2. <ul style="list-style-type: none"> In both the G and the G5 series, the default setting is 0.0 Hz and the damping filter is disabled. * Setting 0.0 to 0.9 Hz disables the damping filter.
Pn2E	Vibration Filter 2 Setting	0.0 Hz	Pn217	Damping Filter 2 Setting	0.0 Hz	Set the vibration suppression effect of the 2nd damping filter. <ul style="list-style-type: none"> In both the G and the G5 series, the default setting is 0.0 Hz.
Pn2F	Adaptive Filter Table Number Display	0	Pn207	Notch 3 Frequency Setting	5,000 Hz	This is a monitor that checks the operating status of adaptive filters. <ul style="list-style-type: none"> For the G series, you can check the operating frequencies of adaptive filters. For the G5 series, the operating status of adaptive filters is updated automatically to the parameters of Notch 3/4 Frequency Setting (Pn207/Pn210). For the default setting, the notch function is disabled at 5,000 Hz.
			Pn210	Notch 4 Frequency Setting	5,000 Hz	
Pn30	Gain Switching Input Operating Mode Selection	1	Pn114	Gain Switching Input Operating Mode Selection	1	Set the function of gain switching input (GSEL). <ul style="list-style-type: none"> The default setting of the G series is 1: <i>Gain 1 (Pn10 to Pn14)/gain 2 (Pn18 to Pn1C) switching enabled.</i> The default setting of the G5 series is 1: <i>Gain 1 (Pn100 to Pn104)/gain 2 (Pn105 to Pn109) switching available.</i> * When 0: <i>Gain 1 (PI/P switching enabled)</i> is set, speed control can be switched to proportional (P) control to reduce the gain.
Pn31	Control Gain Switch 1 Setting	0	Pn115	Switching Mode in Position Control	0	Select a condition for switching between Gain 1 and Gain 2 in the first control mode. <ul style="list-style-type: none"> The default setting of the G series is 0: <i>Always gain 1 (Pn10 to Pn14).</i> For the G5 series, position control, speed control, and torque control can be configured differently. The default setting of Switching Mode in Position Control (Pn115) is 0: <i>Always Gain 1 (Pn100 to Pn104).</i> The default setting of Switching Mode in Speed Control (Pn120) is 0: <i>Always the Gain 1 (Pn100 to Pn104).</i> The default setting of Switching Mode in Torque Control (Pn124) is 0: <i>Always Gain 1 (Pn100 to Pn104).</i>
			Pn120	Switching Mode in Speed Control	0	
			Pn124	Switching Mode in Torque Control	0	
Pn32	Gain Switch 1 Time	30 x 166 us	Pn116	Gain Switching Delay Time in Position Control	5.0 ms	Set the delay time for returning from Gain 2 to Gain 1 in the first control mode. <ul style="list-style-type: none"> The default setting of the G series is 30 x 166 us (4,980 us). For the G5 series, position control, speed control, and torque control can be configured differently. The default setting of Gain Switching Delay Time in Position Control (Pn116) is 5.0 ms. The default setting of Gain Switching Delay Time in Speed Control (Pn121) is 0.0 ms. The default setting of Gain Switching Delay Time in Torque Control (Pn125) is 0.0 ms.
			Pn121	Gain Switching Delay Time in Speed Control	0.0 ms	
			Pn125	Gain Switching Delay Time in Torque Control	0.0 ms	

G series			G5 series			Remarks
Parameter No. [hex]	Parameter name	Default setting [dec]	Parameter No. [dec]	Parameter name	Default setting [dec]	
Pn33	Gain Switch 1 Level Setting	600	Pn117	Gain Switching Level in Position Control	50	<p>Set the judgment level for switching between Gain 1 and Gain 2 in the first control mode.</p> <ul style="list-style-type: none"> The default setting of the G series is 600. * The unit varies with the set value of Control Gain Switch 1 Setting (Pn31). For the G5 series, position control, speed control, and torque control can be configured differently. <ul style="list-style-type: none"> The default setting of Gain Switching Level in Position Control (Pn117) is 50. * The unit varies with the set value of Switching Mode in Position Control (Pn115). The default setting of Gain Switching Level in Speed Control (Pn122) is 0. * The unit varies with the set value of Switching Mode in Speed Control (Pn120). The default setting of Gain Switching Level in Torque Control (Pn126) is 0. * The unit varies with the set value of Switching Mode in Torque Control (Pn124).
			Pn122	Gain Switching Level in Speed Control	0	
			Pn126	Gain Switching Level in Torque Control	0	
Pn34	Gain Switch 1 Hysteresis Setting	50	Pn118	Gain Switching Hysteresis in Position Control	33	<p>Set a hysteresis to the judgment level for switching between Gain 1 and Gain 2 in the first control mode.</p> <ul style="list-style-type: none"> The default setting of the G series is 50. * The unit varies with the set value of Control Gain Switch 1 Setting (Pn31). For the G5 series, position control, speed control, and torque control can be configured differently. <ul style="list-style-type: none"> The default setting of Gain Switching Hysteresis in Position Control (Pn118) is 33. * The unit varies with the set value of Switching Mode in Position Control (Pn115). The default setting of Gain Switching Hysteresis in Speed Control (Pn123) is 0. * The unit varies with the set value of Switching Mode in Speed Control (Pn120). The default setting of Gain Switching Hysteresis in Torque Control (Pn127) is 0. * The unit varies with the set value of Switching Mode in Torque Control (Pn124).
			Pn123	Gain Switching Hysteresis in Speed Control	0	
			Pn127	Gain Switching Hysteresis in Torque Control	0	
Pn35	Position Loop Gain Switching Time	20 x 166 us	Pn119	Position Gain Switching Time	3.3 ms	<p>In switching between Gain 1 and Gain 2, the phased switching time can be set for position loop gain only.</p> <ul style="list-style-type: none"> The default setting of the G series is 20 x 166 us (3,320 us). The default setting of the G5 series is 3.3 ms.

G series			G5 series			Remarks
Parameter No. [hex]	Parameter name	Default setting [dec]	Parameter No. [dec]	Parameter name	Default setting [dec]	
Pn36	Control Gain Switch 2 Setting	0	Pn115	Switching Mode in Position Control	0	Set the gain switching methods in the second control mode. <ul style="list-style-type: none"> For the G series, the gain switching methods are set in the first control mode and the second control mode. * In the first or the second control mode, according to the setting of Control Mode Selection (Pn02), position control, speed control, or torque control is configured. For the G5 series, set the gain switching methods by position control, speed control, or torque control. * Therefore, there is no setting in the first or the second control mode.
			Pn120	Switching Mode in Speed Control	0	
			Pn124	Switching Mode in Torque Control	0	
Pn37	Gain Switch 2 Time	30 x 166 us	Pn116	Gain Switching Delay Time in Position Control	5.0 ms	
			Pn121	Gain Switching Delay Time in Speed Control	0.0 ms	
			Pn125	Gain Switching Delay Time in Torque Control	0.0 ms	
Pn38	Gain Switch 2 Level Setting	0	Pn117	Gain Switching Level in Position Control	50	
			Pn122	Gain Switching Level in Speed Control	0	
			Pn126	Gain Switching Level in Torque Control	0	
Pn39	Gain Switch 2 Hysteresis Setting	0	Pn118	Gain Switching Hysteresis in Position Control	33	
			Pn123	Gain Switching Hysteresis in Speed Control	0	
			Pn127	Gain Switching Hysteresis in Torque Control	0	
Pn3A	Reserved	-	-	-	-	-
Pn3B	Reserved	-	-	-	-	-
Pn3C	Reserved	-	-	-	-	-
Pn3D	Jog Speed	200 r/min	Pn604	Jog Speed	300 r/min	Set the jog speed at which jog operation is performed from the controls on the front of the Serve Drive. <ul style="list-style-type: none"> The default setting differs between G and G5 series.
Pn3E	Reserved	-	-	-	-	-
Pn3F	Reserved	-	-	-	-	-

9.3. Parameters Related to Position Control

G series			G5 series			Remarks
Parameter No. [hex]	Parameter name	Default setting [dec]	Parameter No. [dec]	Parameter name	Default setting [dec]	
Pn40	Command Pulse Input Selection	0	Pn005	Command Pulse Input Selection	0	Select the input terminals for command pulses. <ul style="list-style-type: none"> In both the G and the G5 series, the default setting is <u>0: Photocoupler input (CN1-3 to 6 pins)</u>. * In both the G and the G5 series, if you need not less than the highest response frequency 200 kpps, set <u>1: Line driver (CN1-44 to 47 pins)</u> to input line driver outputs.
Pn41	Command Pulse Rotation Direction Switch	0	Pn006	Command Pulse Rotation Direction Switching Selection	0	Set the motor rotation direction for command pulse inputs. <ul style="list-style-type: none"> In both the G and the G5 series, the default setting is <u>0: The motor rotates in the direction specified by the command pulse</u>.
Pn42	Command Pulse Mode	1	Pn007	Command Pulse Mode Selection	1	Set the input form of input command pulses. <ul style="list-style-type: none"> In both the G and the G5 series, the default setting is <u>1: Reverse pulse and forward pulse inputs</u>.
Pn43	Command Pulse Prohibited Input	1	Pn518	Command Pulse Prohibition Input Setting	1	Set whether to enable or disable the pulse prohibition input (IPG). <ul style="list-style-type: none"> In both the G and the G5 series, the default setting is <u>1: Disabled</u>.
Pn44	Encoder Divider Numerator Setting	2,500	Pn011	Encoder Dividing Numerator	2,500	Set the number of encoder pulses per motor rotation to be output from the Servo Drive. <ul style="list-style-type: none"> In both the G and the G5 series, the default setting of the Encoder Dividing Numerator is <u>2,500</u>. In both the G and the G5 series, the default setting of the Encoder Dividing Numerator is <u>0</u>. * In both the G and the G5 series, if <u>0</u> is set to the Encoder Dividing Numerator , the resolution of the motor in use will be set automatically to the encoder dividing denominator. Therefore, pulses set in the encoder dividing numerator will be output for one motor rotation.
Pn45	Encoder Divider Denominator Setting	0	Pn503	Encoder Dividing Denominator	0	
Pn46	Encoder Output Direction Switch	0	Pn012	Encoder Output Direction Switching Selection	0	Set the logic of the encoder pulses to be output from the Servo Drive. <ul style="list-style-type: none"> In both the G and the G5 series, the default setting is <u>0: Positive logic (Phase A advance in forward operation)</u>.
Pn47	Reserved	-	-	-	-	-

G series			G5 series			Remarks	
Parameter No. [hex]	Parameter name	Default setting [dec]	Parameter No. [dec]	Parameter name	Default setting [dec]		
Pn48	Electronic Gear Ratio Numerator 1	0	Pn008	Electronic Gear Integer Setting	10,000	<p>Set the electronic gear function.</p> <ul style="list-style-type: none"> The default setting of the G series is $Pn48/Pn49 = 0$, $Pn4A = 0$, $Pn4B = 10,000$, meaning 10,000 input pulses for one motor rotation. * If 0 is set to Electronic Gear Ratio Numerator 1/2 (Pn48/Pn49), the resolution of the motor in use will be set automatically to the electronic gear numerator. The G5 series has two setting methods. <ul style="list-style-type: none"> Using Electronic Gear Integer Setting (Pn008) Use Electronic Gear Integer Setting (Pn008) to set the number of input pulses for one motor rotation. The default setting is 10,000, meaning 10,000 input pulses for one motor rotation. Using Electronic Gear Ratio Numerator 1/2 (Pn009/Pn500) and Electronic Gear Ratio Denominator (Pn010) When you set 0 to Electronic Gear Integer Setting (Pn008), the settings of Pn009, Pn500, and Pn010 will be enabled. * If 0 is set to Electronic Gear Ratio Numerator 1/2 (Pn009/Pn500), the resolution of the motor in use will be set automatically to the electronic gear numerator. * The G5 series does not have the Electronic Gear Ratio Numerator Exponent parameter. 	
			Pn009	Electronic Gear Ratio Numerator 1	0		
Pn49	Electronic Gear Ratio Numerator 2	0	Pn500	Electronic Gear Ratio Numerator 2	0		
Pn4A	Electronic Gear Ratio Numerator Exponent	0	-	-	-		
Pn4B	Electronic Gear Ratio Denominator	10,000	Pn010	Electronic Gear Ratio Denominator	10,000		
Pn4C	Position Command Filter Time Constant Setting	0	Pn222	Position Command Filter Time Constant	0.0 ms		<p>Set the first-order lag filter time constant in the command pulse input section.</p> <ul style="list-style-type: none"> In both the G and the G5 series, the default setting is 0.0 ms. Be careful in setting because the setting unit is different.
Pn4D	Smoothing Filter Setting	0	Pn223	Smoothing Filter Time Constant	0.0 ms		<p>Set the FIR filter time constant of command pulses.</p> <ul style="list-style-type: none"> In both the G and the G5 series, the default setting is 0.0 ms. Be careful in setting because the setting unit is different.
Pn4E	Deviation Counter Reset Condition Setting	1	Pn517	Error Counter Reset Condition Selection	3	<p>Set the input time of the error counter reset input (ECRST) that executes error counter reset.</p> <ul style="list-style-type: none"> The default setting of the G series is 1: 100 μs or longer. The default setting of the G5 series is 3: 100 μs or longer. 	
Pn4F	Reserved	-	-	-	-	-	

9.4. Parameters Related to Speed and Torque Control

G series			G5 series			Remarks
Parameter No. [hex]	Parameter name	Default setting [dec]	Parameter No. [dec]	Parameter name	Default setting [dec]	
Pn50	Speed Command Scale	300 (r/min)/V	Pn302	Speed Command Scale	500 (r/min)/V	Set the relation between the input voltage of the speed command input (REF) and the speed command. <ul style="list-style-type: none"> Adjust the setting because the default setting differs between G and G5 series.
Pn51	Command Speed Rotation Direction Switch	0	Pn303	Analog Speed Command Rotation Direction Switching	1	Set the input polarity of the speed command input (REF) and the rotation direction of the speed command. <ul style="list-style-type: none"> The default setting of the G series is <u>0: A positive voltage sets CW direction (reverse direction) seen from axis direction.</u> The default setting of the G5 series is <u>1: A positive voltage sets CW direction (reverse direction) seen from axis direction.</u>
Pn52	Speed Command Offset Adjustment	0 x 0.3 mV	Pn422	Analog Input 1 Offset	0 x 0.359 mV	Set the offset of the speed command input (REF: CN1-14 pin). <ul style="list-style-type: none"> In both the G and the G5 series, the default setting is <i>0 mV</i>. * Automatic adjustment is available to both the G and the G5 series.
Pn53	No. 1 Internally Set Speed	100 r/min	Pn304	No. 1 Internally Set Speed	0 r/min	Set the speed to use in the internally set speed control. <ul style="list-style-type: none"> The default setting differs between G and G5 series.
Pn54	No. 2 Internally Set Speed	200 r/min	Pn305	No. 2 Internally Set Speed	0 r/min	
Pn55	No. 3 Internally Set Speed	300 r/min	Pn306	No. 3 Internally Set Speed	0 r/min	
Pn56	No. 4 Internally Set Speed	50 r/min	Pn307	No. 4 Internally Set Speed	0 r/min	
Pn74	No. 5 Internally Set Speed	500 r/min	Pn308	No. 5 Internally Set Speed	0 r/min	
Pn75	No. 6 Internally Set Speed	600 r/min	Pn309	No. 6 Internally Set Speed	0 r/min	
Pn76	No. 7 Internally Set Speed	700 r/min	Pn310	No. 7 Internally Set Speed	0 r/min	
Pn77	No. 8 Internally Set Speed	800 r/min	Pn311	No. 8 Internally Set Speed	0 r/min	
Pn57	Speed Command Filter Time Constant	0.00 ms	Pn423	Analog Input 1 Filter Time Constant	0.00 ms	Set the first-order lag filter time constant of the speed command input (REF: CN1-14 pin). <ul style="list-style-type: none"> In both the G and the G5 series, the default setting is <i>0 ms</i>.
Pn58	Soft Start Acceleration Time	0 x 2 ms	Pn312	Soft Start Acceleration Time	0 ms	Set the acceleration/deceleration time to the speed command inside the Servo Drive and the internally set speed control. <ul style="list-style-type: none"> In both the G and the G5 series, the default setting is <i>0 ms</i>. In both the G and the G5 series, set the acceleration/deceleration time of up to 1,000 r/min. Be careful in setting because the setting unit is different. * In both the G and the G5 series, for position control, set <i>0 ms</i> to the soft start acceleration/deceleration time.
Pn59	Soft Start Deceleration Time	0 x 2 ms	Pn313	Soft Start Deceleration Time	0 ms	
Pn5A	S-curve Acceleration/Deceleration Time Setting	0 x 2 ms	Pn314	S-curve Acceleration/Deceleration Time Setting	0 ms	Set the pseudo-S-curve acceleration/deceleration value to the speed command. <ul style="list-style-type: none"> In both the G and the G5 series, the default setting is <i>0 ms</i>. Be careful in setting because the setting unit is different.

G series			G5 series			Remarks
Parameter No. [hex]	Parameter name	Default setting [dec]	Parameter No. [dec]	Parameter name	Default setting [dec]	
Pn5B	Torque Command/Speed Limit Selection	0	Pn317	Torque Command/Speed Limit Selection	0	<p>Set the analog input terminals for the torque commands and speed limits in torque control.</p> <ul style="list-style-type: none"> The default setting of the G series is <u>0: Torque command: CN1-14 pin, Speed limit: No. 4 Internally Set Speed (Pn56)</u>. The default setting of the G5 series is <u>0: Torque command: CN1-14 pin, Speed limit: Speed Limit Value Setting (Pn321)</u>. <p>* In both the G and the G5 series, when Control Mode Selection (Pn02/Pn001) is <u>5: Mode 1: Speed control, Mode 2: Torque control</u>, the speed command and the torque command will be assigned to CN1-14 and CN1-16 respectively.</p>
			Pn321	Speed Limit Value Setting	0 r/min	
Pn5C	Torque Command Scale	3.0 V/100%	Pn319	Torque Command Scale	3.0 V/100%	<p>Set the relation between the input voltage of the torque command input (TREF) and the torque command.</p> <ul style="list-style-type: none"> In both the G and the G5 series, the default setting is <u>3.0 V/100%</u>.
Pn5D	Torque Output Direction Switch	0	Pn320	Analog Torque Command Rotation Direction Switching	0	<p>Set the input polarity of the torque command input (TREF) and the rotation direction of the torque command.</p> <ul style="list-style-type: none"> In both the G and the G5 series, the default setting is <u>0: A positive voltage sets CW direction (reverse direction) seen from axis direction</u>.
Pn5E	No. 1 Torque Limit	300 %	Pn013	No. 1 Torque Limit	500 %	<p>Set the limit value of torque limits in units of %, with the rated motor torque regarded as 100%.</p> <ul style="list-style-type: none"> The default setting differs between G and G5 series. For the G series, you can use the setting of Torque Limit Selection (Pn03) to set how to limit torque. <ul style="list-style-type: none"> The default selection of Torque Limit Selection (Pn03) is <u>1: No. 1 Torque Limit (Pn5E) for both forward and reverse operation</u>. For the G5 series, you can use the setting of Torque Limit Selection (Pn521) to set how to limit torque. <ul style="list-style-type: none"> The default selection of Torque Limit Selection (Pn521) is <u>1: No. 1 Torque Limit (Pn013) for both forward and reverse operation</u>.
Pn5F	No. 2 Torque Limit	100 %	Pn522	No. 2 Torque Limit	500 %	

9.5. Parameters Related to Sequence

G series			G5 series			Remarks
Parameter No. [hex]	Parameter name	Default setting [dec]	Parameter No. [dec]	Parameter name	Default setting [dec]	
Pn60	Positioning Completion Range	25 Encoder unit	Pn431	Positioning Completion Range 1	10 Command unit	Set the positioning completion range. <ul style="list-style-type: none"> For the G series, the encoder unit (multiple of 4) is used in setting. For the G5 series, the command unit (command pulse unit) is used in setting. * Be careful in setting because the setting unit and motor resolution are different between the G and the G5 series. * The setting unit of the G5 series can be changed to 1: <i>Encoder units (external scale units)</i> by using Position Setting Unit Selection (Pn520).
			Pn520	Position Setting Unit Selection	0	
Pn61	Zero Speed Detection	20 r/min	Pn434	Zero Speed Detection	50 r/min	Set the rotation speed at which to output the zero speed detection output. <ul style="list-style-type: none"> The default setting differs between G and G5 series.
Pn62	Rotation Speed for Motor Rotation Detection	50 r/min	Pn436	Rotation Speed for Motor Rotation Detection	1,000 r/min	Set the rotation speed at which to output the motor rotation speed detection output (TGON). <ul style="list-style-type: none"> The default setting differs between G and G5 series.
Pn63	Positioning Completion Condition Setting	0	Pn432	Positioning Completion Condition Selection	0	Set the condition on which to output the positioning completion output (INP). <ul style="list-style-type: none"> The default setting of the G series is <i>Positioning completion output turns ON when the position error is within the Positioning Completion Range (Pn60)</i>. The default setting of the G5 series is <i>Positioning completion output (INP1) turns ON when the position error is within the Positioning Completion Range 1 (Pn431)</i>.
Pn64	Reserved	-	-	-	-	-
Pn65	Undervoltage Alarm Selection	1	Pn508	Undervoltage Alarm Selection	1	Set whether to enable or disable a Main power supply undervoltage (Alarm No. 13). <ul style="list-style-type: none"> In both the G and the G5 series, the default setting is <u>1: During Servo ON status, a main power supply undervoltage (Alarm No. 13) is detected</u>.
Pn66	Stop Selection for Drive Prohibition Input	0	Pn505	Stop Selection for Drive Prohibition Input	0	Set the stop method when the drive prohibition function is activated by the input of Forward/Reverse drive prohibition input (POT/NOT). <ul style="list-style-type: none"> In both the G and the G5 series, the default setting is <u>0: After a dynamic brake stop (error counter cleared), the torque command is 0 in the drive prohibition direction (error counter held)</u>.
Pn67	Stop Selection with Main Power OFF	0	Pn507	Stop Selection with Main Power Supply OFF	0	Set the stop method for main power supply OFF. <ul style="list-style-type: none"> In both the G and the G5 series, the default setting is <u>0: After a dynamic brake stop, the dynamic brake is held</u>. * However, if any alarm (error) is detected during a stop, it will be overridden by Stop Selection for Alarm Generation/Stop Selection for Alarm Detection (Pn68/Pn510).
Pn68	Stop Selection for Alarm Generation	0	Pn510	Stop Selection for Alarm Detection	0	Set the stop method for alarm (error) occurrence. <ul style="list-style-type: none"> In both the G and the G5 series, the default setting is <u>0: After a dynamic brake stop, the dynamic brake is held</u>.
Pn69	Stop Selection with Servo OFF	0	Pn506	Stop Selection with Servo OFF	0	Set the stop method for servo OFF. <ul style="list-style-type: none"> In both the G and the G5 series, the default setting is <u>0: After a dynamic brake stop, the dynamic brake is held</u>.

G series			G5 series			Remarks
Parameter No. [hex]	Parameter name	Default setting [dec]	Parameter No. [dec]	Parameter name	Default setting [dec]	
Pn6A	Brake Timing When Stopped	10 x 2 ms	Pn437	Brake Timing when Stopped	0 ms	Set the servo ON hold time, at servo OFF, after the brake interlock output turned OFF. <ul style="list-style-type: none"> The default setting differs between G and G5 series.
Pn6B	Brake Timing during Operation	50 x 2 ms	Pn438	Brake Timing During Operation	0 ms	Set the time spent waiting for the brake that reduces rotation to be applied when the Servo OFF is applied to the running motor. <ul style="list-style-type: none"> The default setting of the G series is 50 x 2 ms (100 ms). * For the G series, when the speed reaches 30 r/min or less, the brake will be applied even if the wait time set in Brake Timing during Operation (Pn6B) has not elapsed. The default setting of the G5 series is 0 ms. * For the G5 series, when the motor speed reaches not more than the speed set in Brake Release Speed Setting (Pn439), the brake will be applied even if the wait time set in Brake Timing During Operation (Pn438) has not elapsed.
			Pn439	Brake Release Speed Setting	30 r/min	
Pn6C	Regeneration Resistor Selection	0	Pn016	Regeneration Resistor Selection	3/0*2	Set the regeneration processing method. <ul style="list-style-type: none"> The default setting of the G series is 0: <u>Built-in regeneration resistor</u>. * Even if the Servo Drive does not have a built-in regeneration resistor, this is acceptable to operation. The default setting of the G5 series is 3: <u>Built-in capacitor</u>. * The default setting of the Servo Drive with a built-in regeneration resistor is 0: <u>Built-in regeneration resistor</u>.
Pn6D	Momentary Hold Time	35 x 2 ms	Pn509	Momentary Hold Time	70 ms	Set the time spent waiting for a Main power supply undervoltage (Alarm No. 13) to be detected after the main power supply is shut off. <ul style="list-style-type: none"> In both the G and the G5 series, the default setting is 70 ms. Be careful in setting because the setting unit is different.
Pn6E	Emergency Stop Torque	0 %	Pn511	Immediate Stop Torque	0 %	Set the stop torque to be used when you select an emergency stop method at Stop Selection for Drive Prohibition Input (Pn66/Pn505), Stop Selection with Main Power Supply OFF (Pn67/Pn507), or Stop Selection with Servo OFF (Pn69/Pn506). <ul style="list-style-type: none"> In both the G and the G5 series, the default setting is 0%. * In both the G and the G5 series, when you set 0%, the set torque limit value will be used.
Pn6F	Reserved	-	-	-	-	-
Pn70	Deviation Counter Overflow Level	100 x 256 Encoder unit	Pn014	Error Counter Overflow Level	100,000 Command unit	Set the detection level of an Error Counter Overflow Error (Alarm No. 24). <ul style="list-style-type: none"> For the G series, the encoder unit (multiple of 4) is used in setting. For the G5 series, the command unit (command pulse unit) is used in setting. * Be careful in setting because the setting unit and motor resolution are different between the G and the G5 series. * The setting unit of the G5 series can be changed to 1: <i>Encoder units (external scale units)</i> by using Position Setting Unit Selection (Pn520).
			Pn520	Position Setting Unit Selection	0	

*2. For the numerical notation sv/SV, sv represents the setting for the following drives. SV represents the setting for other drives.

- 100 V type: 200 W or less
- 200 V type: 400 W or less, 7.5 kW, 15 kW
- 400 V type: 7.5 kW, 15 kW

G series			G5 series			Remarks
Parameter No. [hex]	Parameter name	Default setting [dec]	Parameter No. [dec]	Parameter name	Default setting [dec]	
Pn71	Speed Command/Torque Command Input Overflow Level Setting	0.0 V	Pn424	Excessive Analog Input 1	0.0 V	Set the value that detects an Excessive analog input (Alarm No. 39) in the speed command (REF) or the torque command (TREF). <ul style="list-style-type: none"> In both the G and the G5 series, for the default setting, the Excessive analog input (Alarm No. 39) is disabled at 0.0 V. In both the G and the G5 series, when you set 0.0 V, the Excessive analog input (Alarm No. 39) will be disabled.
			Pn427	Excessive Analog Input 2	0.0 V	
			Pn430	Excessive Analog Input 3	0.0 V	
Pn72	Overload Detection Level Setting	0 %	Pn512	Overload Detection Level Setting	0 %	Set the detection level of an Overload (Alarm No. 16). <ul style="list-style-type: none"> In both the G and the G5 series, the default setting is 0%. In both the G and the G5 series, when you set 0%, the Overload (Alarm No. 16) will be detected at 115%.
Pn73	Overspeed Detection Level Setting	0 r/min	Pn513	Overspeed Detection Level Setting	0 r/min	Set the detection level of an Overspeed error (Alarm No. 26). <ul style="list-style-type: none"> In both the G and the G5 series, the default setting is 0 r/min. In both the G and the G5 series, if you set 0 r/min, it will be detected when the motor speed is 1.2 times as high as the maximum one.
Pn78	Reserved	-	-	-	-	-
Pn79	Reserved	-	-	-	-	-
Pn7A	Reserved	-	-	-	-	-
Pn7B	Reserved	-	-	-	-	-
Pn7C	Reserved	-	-	-	-	-
Pn7D	Reserved	-	-	-	-	-
Pn7E	Reserved	-	-	-	-	-
Pn7F	Reserved	-	-	-	-	-

Appendix. List of Cables Connecting G5-series Servo Drives and Servomotors

Rated rotation speed	Main circuit power supply voltage	Motor capacity	Motor model R88M-	Power cable without brake R88A-		Power cable with brake R88A-		Encoder cable R88A-				
				Standard	Flexible	Standard	Flexible	Standard	Flexible			
3,000 r/min	100 V	50 W	K05030H/T□	CAKA△S	CAKA△SR	CAKA△S, CAKA△B	CAKA△SR, CAKA△BR	CRKA△C *3	CRKA△CR *3			
		100 W	K10030L/S□									
		200 W	K20030L/S□									
		400 W	K40030L/S□									
	200 V	50 W	K05030H/T□	CAKA△S	CAKA△SR	CAKA△S, CAKA△B	CAKA△SR, CAKA△BR					
		100 W	K10030H/T□									
		200 W	K20030H/T□									
		400 W	K40030H/T□									
		750 W	K75030H/T□	CAGB△S	CAGB△SR	CAGB△B	CAGB△BR					
		1 kW	K1K030H/T□									
		1.5 kW	K1K530H/T□									
		2 kW	K2K030H/T□									
	400 V	3 kW	K3K030H/T□	CAGD△S	CAGD△SR	CAGD△B	CAGD△BR					
		4 kW	K4K030H/T□									
		5 kW	K5K030H/T□									
		750 W	K75030F/C□							CAGB△S	CAGB△SR	CAKF△B
1 kW		K1K030F/C□										
1.5 kW		K1K530F/C□										
2 kW		K2K030F/C□										
3 kW		K3K030F/C□	CAGD△S	CAGD△SR	CAGD△B	CAGD△BR						
4 kW	K4K030F/C□											
5 kW	K5K030F/C□											
2,000 r/min	200 V	1 kW	K1K020H/T□	CAGB△S	CAGB△SR	CAGB△B	CAGB△BR	CRKC△N *3	CRKC△NR *3			
		1.5 kW	K1K520H/T□									
		2 kW	K2K020H/T□									
		3 kW	K3K020H/T□									
		4 kW	K4K020H/T□									
	5 kW	K5K020H/T□	CAGD△S	CAGD△SR	CAGD△B	CAGD△BR						
	400 V	400 W					K40020F/C□					
		600 W					K60020F/C□					
		1 kW					K1K020F/C□					
		1.5 kW					K1K520F/C□					
		2 kW					K2K020F/C□					
	3 kW	K3K020F/C□					CAGD△S			CAGD△SR	CAGD△B	CAGD△BR
	4 kW	K4K020F/C□										
	5 kW	K5K020F/C□										
1,500 r/min	200 V	7.5 kW	K7K515T□	CAGE△S	*2	CAGE△S, CAGE△B	*2	CRKC△N *3	CRKC△NR *3			
	400 V	7.5 kW	K7K515C□									
1,000 r/min	200 V	900 W	K90010H/T□	CAGB△S	CAGB△SR	CAGB△B	CAGB△BR	CRKC△N *3	CRKC△NR *3			
		2 kW	K2K010H/T□									
		3 kW	K3K010H/T□									
		4.5 kW	K4K510T□									
	400 V	6 kW	K6K010T□	CAGE△S	*2	CAGE△S, CAGE△B	*2					
		900 W	K90010F/C□									
		2 kW	K2K010F/C□	CAGD△S	CAGD△SR	CAGD△B	CAGD△BR					
		3 kW	K3K010F/C□									
		4.5 kW	K4K510C□									
		6 kW	K6K010C□									

*1. □ represents an optional specification for the motor. △ represents a 3-digit cable length (005 for 5 m).

*2. We have no plan to commercialize flexible-type power cables for 6 kW and 7.5 kW motors. They must be prepared by the customer.

*3. When you use an absolute (absolute value) encoder, use the battery cable for absolute encoder (R88A-CRGD0R3C) in addition.

Note: Do not use this document to operate the Unit.

OMRON Corporation Industrial Automation Company

Tokyo, JAPAN

Contact: www.ia.omron.com

Regional Headquarters

OMRON EUROPE B.V.

Wegalaan 67-69, 2132 JD Hoofddorp
The Netherlands
Tel: (31)2356-81-300/Fax: (31)2356-81-388

OMRON ELECTRONICS LLC

2895 Greenspoint Parkway, Suite 200
Hoffman Estates, IL 60169 U.S.A
Tel: (1) 847-843-7900/Fax: (1) 847-843-7787

OMRON ASIA PACIFIC PTE. LTD.

No. 438A Alexandra Road # 05-05/08 (Lobby 2),
Alexandra Technopark,
Singapore 119967
Tel: (65) 6835-3011/Fax: (65) 6835-2711

OMRON (CHINA) CO., LTD.

Room 2211, Bank of China Tower,
200 Yin Cheng Zhong Road,
PuDong New Area, Shanghai, 200120, China
Tel: (86) 21-5037-2222/Fax: (86) 21-5037-2200

Authorized Distributor:

© OMRON Corporation 2022 All Rights Reserved.
In the interest of product improvement,
specifications are subject to change without notice.

Cat. No. I877-E1-01

0422 (0422)