

Best-selling Guard Lock Safety-door Switch Available in Several Compact, Multi-contact Models

- Selectable Operation Key insertion direction and adjustable mounting ensure installation flexibility.
- Built-in switches with multiple-contact construction are available.
- Key holding force of 1,300 N minimum.
- Can be used for either standard loads or microloads.
- Lineup includes models with a conduit outlet of M20.
- IP67 degree of protection.
- Variety of Metallic Heads Available.



For the most recent information on models that have been certified for safety standards, refer to your OMRON website.



Be sure to read the "Safety Precautions" on page 14.

Model Number Structure

Model Number Legend

Switch (Standard type)

D4NL-□□□□-□□□□
1 2 3 4 5 6 7

- 1. Conduit Outlet**
 - 1: Pg13.5
 - 2: G1/2
 - 4: M20
- 2. Built-in Switch (with Door Open/Closed Detection Switch and Lock Monitor Switch Contacts)**
 - A: 1NC/1NO (slow-action contacts) + 1NC/1NO (slow-action contacts)
 - B: 1NC/1NO (slow-action contacts) + 2NC (slow-action contacts)
 - C: 2NC (slow-action contacts) + 1NC/1NO (slow-action contacts)
 - D: 2NC (slow-action contacts) + 2NC (slow-action contacts)
 - E: 2NC/1NO (slow-action contacts) + 1NC/1NO (slow-action contacts)
 - F: 2NC/1NO (slow-action contacts) + 2NC (slow-action contacts)
 - G: 3NC (slow-action contacts) + 1NC/1NO (slow-action contacts)
 - H: 3NC (slow-action contacts) + 2NC (slow-action contacts)
- 3. Head Mounting Direction and Material**
 - F: Four mounting directions possible (Front-side mounting at shipping)/plastic
 - D: Four mounting directions possible (Front-side mounting at shipping)/metal
- 4. Door Lock and Release**
 - A: Mechanical lock/24 VDC solenoid release
 - B: Mechanical lock/110 VAC solenoid release
 - G: 24 VDC solenoid lock/mechanical release
 - H: 110 VAC solenoid lock/mechanical release
- 5. Indicator**
 - B: 10 to 115 VAC/VDC (orange LED indicator)
- 6. Release Key Type**
 - Blank: Standard (resin)
 - 4: Special release key (resin)
(Note: Release tool is included.)
- 7. Release Key Position**
 - Blank: Bottom
 - S: Front

Switch (Metallic release key type)

D4NL-□□□□-□□□□-SJ
1 2 3 4 5 6 7

- 1. Conduit Outlet**
 - 2: G1/2 (1-conduit type)
 - 4: M20 (1-conduit type)
- 2. Built-in Switch**
 - E: 2NC/1NO + 1NC/1NO
 - F: 2NC/1NO + 2NC
 - G: 3NC + 1NC/1NO
 - H: 3NC + 2NC
- 3. Head Mounting Direction and Material**
 - F: Four mounting directions possible (Front-side mounting at shipping)/resin
- 4. Door Lock and Release**
 - A: Mechanical lock/ 24 VDC solenoid release
 - G: 24 VDC solenoid lock/ mechanical release
- 5. Indicator**
 - B: 10 to 115 VAC/VDC (orange LED indicator)
- 6. Release Key Type**
 - Blank: Standard (metal)
- 7. Release Key Position**
 - Blank: Bottom

Operation Key

D4DS-K□

1

- 1. Operation Key Type**
 - 1: Horizontal mounting
 - 2: Vertical mounting
 - 3: Adjustable mounting (horizontal)
 - 5: Adjustable mounting (horizontal/vertical)

Ordering Information

List of Models

Switches (Operation Keys are sold separately.)

Consult with your OMRON representative when ordering any models that are not listed in this table.

Head material	Release key position	Release key type	Solenoid voltage/indicator	Lock and release types	Contact configuration (door open/closed detection switch and lock monitor switch contacts) (slow-action) Certified direct opening NC contact	Conduit outlet	Model
Plastic *1	Bottom	Standard (resin)	Solenoid: 24 VDC Orange LED: 10 to 115 VAC/VDC	Mechanical lock Solenoid release	1NC/1NO+1NC/1NO	Pg13.5	D4NL-1AFA-B
						G1/2	D4NL-2AFA-B
						M20	D4NL-4AFA-B
					1NC/1NO+2NC	Pg13.5	D4NL-1BFA-B
						G1/2	D4NL-2BFA-B
						M20	D4NL-4BFA-B
					2NC+1NC/1NO	Pg13.5	D4NL-1CFA-B
						G1/2	D4NL-2CFA-B
						M20	D4NL-4CFA-B
					2NC+2NC	Pg13.5	D4NL-1DFA-B
						G1/2	D4NL-2DFA-B
						M20	D4NL-4DFA-B
					2NC/1NO+1NC/1NO	Pg13.5	D4NL-1EFA-B
						G1/2	D4NL-2EFA-B *2
						M20	D4NL-4EFA-B *2
					2NC/1NO+2NC	Pg13.5	D4NL-1FFA-B
						G1/2	D4NL-2FFA-B *2
						M20	D4NL-4FFA-B *2
					3NC+1NC/1NO	Pg13.5	D4NL-1GFA-B
						G1/2	D4NL-2GFA-B *2
						M20	D4NL-4GFA-B *2
					3NC+2NC	Pg13.5	D4NL-1HFA-B
						G1/2	D4NL-2HFA-B *2
						M20	D4NL-4HFA-B *2
				Solenoid lock Mechanical release	1NC/1NO+1NC/1NO	Pg13.5	D4NL-1AFG-B
						G1/2	D4NL-2AFG-B
						M20	D4NL-4AFG-B
					1NC/1NO+2NC	Pg13.5	D4NL-1BFG-B
						G1/2	D4NL-2BFG-B
						M20	D4NL-4BFG-B
					2NC+1NC/1NO	Pg13.5	D4NL-1CFG-B
						G1/2	D4NL-2CFG-B
						M20	D4NL-4CFG-B
					2NC+2NC	Pg13.5	D4NL-1DFG-B
						G1/2	D4NL-2DFG-B
						M20	D4NL-4DFG-B
					2NC/1NO+1NC/1NO	Pg13.5	D4NL-1EFG-B
						G1/2	D4NL-2EFG-B *2
						M20	D4NL-4EFG-B *2
					2NC/1NO+2NC	Pg13.5	D4NL-1FFG-B
						G1/2	D4NL-2FFG-B *2
						M20	D4NL-4FFG-B *2
					3NC+1NC/1NO	Pg13.5	D4NL-1GFG-B
						G1/2	D4NL-2GFG-B *2
						M20	D4NL-4GFG-B *2
					3NC+2NC	Pg13.5	D4NL-1HFG-B
						G1/2	D4NL-2HFG-B *2
						M20	D4NL-4HFG-B *2

*1. Switches with metal heads can also be manufactured upon request. Ask your OMRON representative for details.

*2. Models with Korean S-mark certification.

Head material	Release key position	Release key type	Solenoid voltage/indicator	Lock and release types	Contact configuration (door open/closed detection switch and lock monitor switch contacts) (slow-action) Certified direct opening NC contact	Conduit outlet	Model
Plastic *1	Bottom	Special release key (resin)	Solenoid: 24 VDC Orange LED: 10 to 115 VAC/VDC	Mechanical lock Solenoid release	1NC/1NO+1NC/1NO	Pg13.5	D4NL-1AFA-B4
						G1/2	D4NL-2AFA-B4
						M20	D4NL-4AFA-B4
					1NC/1NO+2NC	Pg13.5	D4NL-1BFA-B4
						G1/2	D4NL-2BFA-B4
						M20	D4NL-4BFA-B4
					2NC+1NC/1NO	Pg13.5	D4NL-1CFA-B4
						G1/2	D4NL-2CFA-B4
						M20	D4NL-4CFA-B4
					2NC+2NC	Pg13.5	D4NL-1DFA-B4
						G1/2	D4NL-2DFA-B4
						M20	D4NL-4DFA-B4
					2NC/1NO+1NC/1NO	Pg13.5	D4NL-1EFA-B4
						G1/2	D4NL-2EFA-B4 *2
						M20	D4NL-4EFA-B4 *2
					2NC/1NO+2NC	Pg13.5	D4NL-1FFA-B4
						G1/2	D4NL-2FFA-B4 *2
						M20	D4NL-4FFA-B4 *2
					3NC+1NC/1NO	Pg13.5	D4NL-1GFA-B4
						G1/2	D4NL-2GFA-B4 *2
						M20	D4NL-4GFA-B4 *2
					3NC+2NC	Pg13.5	D4NL-1HFA-B4
						G1/2	D4NL-2HFA-B4 *2
						M20	D4NL-4HFA-B4 *2
				Solenoid lock Mechanical release	1NC/1NO+1NC/1NO	Pg13.5	D4NL-1AFG-B4
						G1/2	D4NL-2AFG-B4
						M20	D4NL-4AFG-B4
					1NC/1NO+2NC	Pg13.5	D4NL-1BFG-B4
						G1/2	D4NL-2BFG-B4
						M20	D4NL-4BFG-B4
					2NC+1NC/1NO	Pg13.5	D4NL-1CFG-B4
						G1/2	D4NL-2CFG-B4
						M20	D4NL-4CFG-B4
					2NC+2NC	Pg13.5	D4NL-1DFG-B4
						G1/2	D4NL-2DFG-B4
						M20	D4NL-4DFG-B4
					2NC/1NO+1NC/1NO	Pg13.5	D4NL-1EFG-B4
						G1/2	D4NL-2EFG-B4 *2
						M20	D4NL-4EFG-B4 *2
					2NC/1NO+2NC	Pg13.5	D4NL-1FFG-B4
						G1/2	D4NL-2FFG-B4 *2
						M20	D4NL-4FFG-B4 *2
					3NC+1NC/1NO	Pg13.5	D4NL-1GFG-B4
						G1/2	D4NL-2GFG-B4 *2
						M20	D4NL-4GFG-B4 *2
					3NC+2NC	Pg13.5	D4NL-1HFG-B4
						G1/2	D4NL-2HFG-B4 *2
						M20	D4NL-4HFG-B4 *2



*1. Switches with metal heads can also be manufactured upon request. Ask your OMRON representative for details.

*2. Models with Korean S-mark certification.

Head material	Release key position	Release key type	Solenoid voltage/ indicator	Lock and release types	Contact configuration (door open/closed detection switch and lock monitor switch contacts) (slow-action) Certified direct opening NC contact	Conduit outlet	Model
Plastic	Bottom	Standard (metal)	Solenoid: 24 VDC Orange LED: 10 to 115 VAC/VDC	Mechanical lock Solenoid release	2NC/1NO+1NC/1NO	G1/2	D4NL-2EFA-B-SJ *2
						M20	D4NL-4EFA-B-SJ *2
					2NC/1NO+2NC	G1/2	D4NL-2FFA-B-SJ *2
						M20	D4NL-4FFA-B-SJ *2
					3NC+1NC/1NO	G1/2	D4NL-2GFA-B-SJ *2
						M20	D4NL-4GFA-B-SJ *2
					3NC+2NC	G1/2	D4NL-2HFA-B-SJ *2
						M20	D4NL-4HFA-B-SJ *2
				Solenoid lock Mechanical release	2NC/1NO+1NC/1NO	G1/2	D4NL-2EFG-B-SJ *2
						M20	D4NL-4EFG-B-SJ *2
					2NC/1NO+2NC	G1/2	D4NL-2FFG-B-SJ *2
						M20	D4NL-4FFG-B-SJ *2
					3NC+1NC/1NO	G1/2	D4NL-2GFG-B-SJ *2
						M20	D4NL-4GFG-B-SJ *2
					3NC+2NC	G1/2	D4NL-2HFG-B-SJ *2
						M20	D4NL-4HFG-B-SJ *2

*2. Models with Korean S-mark certification.

Operation Keys

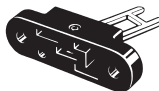
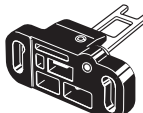
Type	Model
Horizontal mounting 	D4DS-K1
Vertical mounting 	D4DS-K2
Adjustable mounting (Horizontal) 	D4DS-K3
Adjustable mounting (Horizontal/Vertical) 	D4DS-K5

Specifications

Standards and EC Directives

Conforms to the following EC Directives:

- Machinery Directive
- Low Voltage Directive
- EN ISO 14119
- EN60947-5-1

Certified Standards

Standard type

Certification body	Standard	File No.
TÜV SÜD	EN60947-5-1 (certified direct opening)	Consult your OMRON representative for details.
UL *1	UL508, CSA C22.2 No.14	E76675
CQC (CCC)	GB/T 14048.5	Consult your OMRON representative for details.
KOSHA *2	EN60947-5-1	Consult your OMRON representative for details.

*1. Certification for CSA C22.2 No. 14 is authorized by the UL mark.

*2. Only certain models have been certified.

Metallic release key type

Certification body	Standard	File No.
TÜV SÜD	EN60947-5-1 (certified direct opening)	Consult your OMRON representative for details.
KOSHA	EN60947-5-1	Consult your OMRON representative for details.

Certified Standard Ratings

TÜV (EN60947-5-1), CCC (GB/T 14048.5)

Item	Utilization category	AC-15	DC-13
Rated operating current (I _e)		3 A	0.27 A
Rated operating voltage (U _e)		240 V	250 V

Note: Use a 10 A fuse type gI or gG that conforms to IEC60269 as a short-circuit protection device. This fuse is not built into the Switch.

UL/CSA (UL508, CSA C22.2 No. 14)

A300

Rated voltage	Carry current	Current (A)		Volt-amperes (VA)	
		Make	Break	Make	Break
120 VAC	10 A	60	6	7,200	720
240 VAC		30	3		

Q300

Rated voltage	Carry current	Current (A)		Volt-amperes (VA)	
		Make	Break	Make	Break
125 VDC	2.5 A	0.55	0.55	69	69
250 VDC		0.27	0.27		

Solenoid Coil Characteristics

Item	Type	24 VDC	110 VAC
Rated operating voltage (100% ED)		24 VDC ^{+10%} _{-15%}	110 VAC ±10%
Current consumption		Approx. 200 mA	Approx. 50 mA
Insulation		Class B (130°C max.)	

Indicator Characteristics

Item	Type	LED
Rated voltage		10 to 115 VAC/VDC
Current leakage		Approx. 1 mA
Color (LED)		Orange

Characteristics

Interlock type		Type 2 (EN ISO 14119)
Coding level		Low level coded (EN ISO 14119)
Degree of protection *1		IP67 (EN60947-5-1)
Durability *2	Mechanical	1,000,000 operations min.
	Electrical	500,000 operations min. (3 A resistive load at 250 VAC) *3
Operating speed		0.05 to 0.5 m/s
Operating frequency		30 operations/minute max.
Direct opening force *4		60 N min. (EN60947-5-1)
Direct opening travel *4		10 mm min. (EN60947-5-1)
Holding force (Fzh) *5		1,300 N min.
Contact resistance		25 mΩ max. (per contact)
Minimum applicable load *6		1 mA resistive load at 5 VDC (N-level reference value)
Rated insulation voltage (U_i)		300 V (EN60947-5-1)
Rated frequency		50/60 Hz
Protection against electric shock		Class II (double insulation) □
Pollution degree (operating environment)		3 (EN60947-5-1)
Impulse withstand voltage (U_{imp}) (EN60947-5-1)	Between terminals of same polarity	2.5 kV
	Between terminals of different polarity	4 kV
	Between each terminal and non-current carrying metallic parts	6 kV
Insulation resistance		100 MΩ min. (at 500 VDC)
Contact gap		2 × 2 mm min.
Vibration resistance	Malfunction	10 to 55 Hz, 0.75 mm single amplitude
	Destruction	1,000 m/s ² min.
Shock resistance	Malfunction	100 m/s ² min.
	Conditional short-circuit current	100 A (EN60947-5-1)
Conventional free air thermal current (I_{th})		10 A (EN60947-5-1)
Ambient operating temperature		-10 to 55°C (with no icing)
Ambient operating humidity		95% max.
Weight		Approx. 370 g (D4NL-1AFA-B)

Note: 1. The above values are initial values.

2. The Switch contacts can be used with either standard loads or microloads. Once the contacts have been used to switch a load, however, they cannot be used to switch smaller loads. The contact surfaces will become rough once they have been used and contact reliability for smaller loads may be reduced.

*1. The degree of protection is tested using the method specified by the standard (EN60947-5-1). Confirm that sealing properties are sufficient for the operating conditions and environment beforehand. Although the switch box is protected from dust or water penetration, do not use the D4NL in places where foreign material may enter through the key hole on the head, otherwise Switch damage or malfunctioning may occur.

*2. The durability is for an ambient temperature of 5 to 35°C and an ambient humidity of 40% to 70%. For more details, consult your OMRON representative.

*3. Do not pass the 3 A, 250 VAC load through more than 2 circuits.

*4. These figures are minimum requirements for safe operation.

*5. This figure is based on the EN ISO 14119 evaluation method.

*6. This value will vary with the switching frequency, environment, and reliability level. Confirm that correct operation is possible with the actual load beforehand.

Connections

Internal Circuit Diagram

Indicator

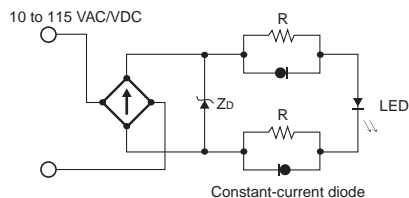

Solenoid

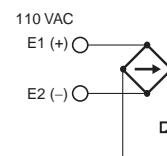
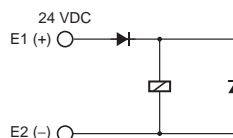

Operation Method

Operation Principles

<p>Mechanical lock models</p>		<p>When the Operation Key is inserted, it is locked by the lock spring. The door will stay locked even if there is a power interruption.</p>	<p>The solenoid is released only when the lock is turned ON.</p>
<p>Solenoid lock models</p>		<p>If the solenoid is OFF, the door will not be locked when the Operation Key is inserted. This means that the door can be opened and closed easily when replacing workpieces or parts.</p>	<p>The door is locked only when the solenoid is turned ON. This means that the door will be unlocked if there is a power interruption and so this model cannot be used in systems that would maintain a hazardous state (e.g., systems requiring toxic gases, high temperatures, or gears that would continue to turn due to inertia).</p>

Structure and Nomenclature

Structure

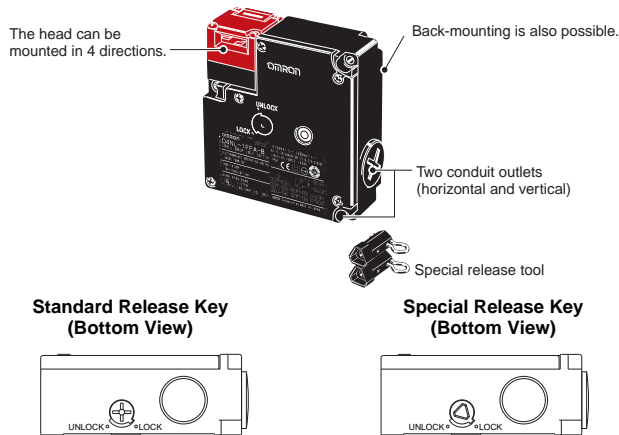
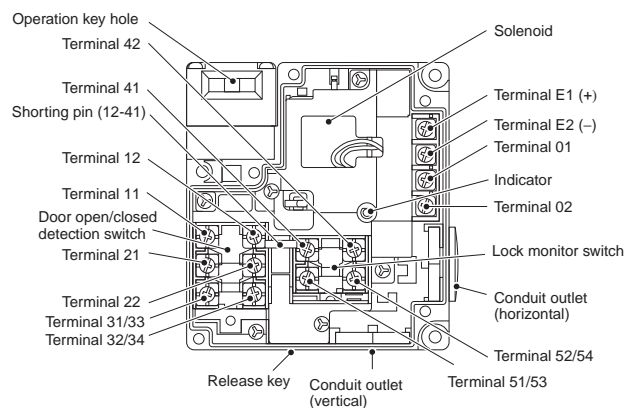

Note: Terminal numbers vary with the model.

Model and Contact Configuration

Indicates conditions where the Key is inserted and the lock is applied. Terminals 12 and 41 are connected internally.

Model	Contact (door open/closed detection and lock monitor)	Contact form		Operating pattern	Remarks
		Door open/ closed detection	Lock monitor		
D4NL-□AF□-□	1NC/1NO + 1NC/1NO				Only NC contacts 11-12 have a certified direct opening mechanism. (→) The terminals 11-42, 33-34, and 53-54 can be used as unlike poles.
D4NL-□BF□-□	1NC/1NO + 2NC				Only NC contacts 11-12 have a certified direct opening mechanism. (→) The terminals 11-42, 33-34, and 51-52 can be used as unlike poles.
D4NL-□CF□-□	2NC + 1NC/1NO				Only NC contacts 11-12 and 31-32 have a certified direct opening mechanism. (→) The terminals 11-42, 31-32, and 53-54 can be used as unlike poles.
D4NL-□DF□-□	2NC + 2NC				Only NC contacts 11-12 and 31-32 have a certified direct opening mechanism. (→) The terminals 11-42, 31-32, and 51-52 can be used as unlike poles.
D4NL-□EF□-□	2NC/1NO + 1NC/1NO				Only NC contacts 11-12 and 21-22 have a certified direct opening mechanism. (→) The terminals 11-42, 21-22, 33-34, and 53-54 can be used as unlike poles.
D4NL-□FF□-□	2NC/1NO + 2NC				Only NC contacts 11-12 and 21-22 have a certified direct opening mechanism. (→) The terminals 11-42, 21-22, 33-34, and 51-52 can be used as unlike poles.
D4NL-□GF□-□	3NC + 1NC/1NO				Only NC contacts 11-12, 21-22, and 31-32 have a certified direct opening mechanism. (→) The terminals 11-42, 21-22, 31-32, and 53-54 can be used as unlike poles.
D4NL-□HF□-□	3NC + 2NC				Only NC contacts 11-12, 21-22, and 31-32 have a certified direct opening mechanism. (→) The terminals 11-42, 21-22, 31-32, and 51-52 can be used as unlike poles.

Dimensions

Dimensions and Operating Characteristics

Switches

D4NL-□□□□-B

D4NL-□□□□-□□□-SJ

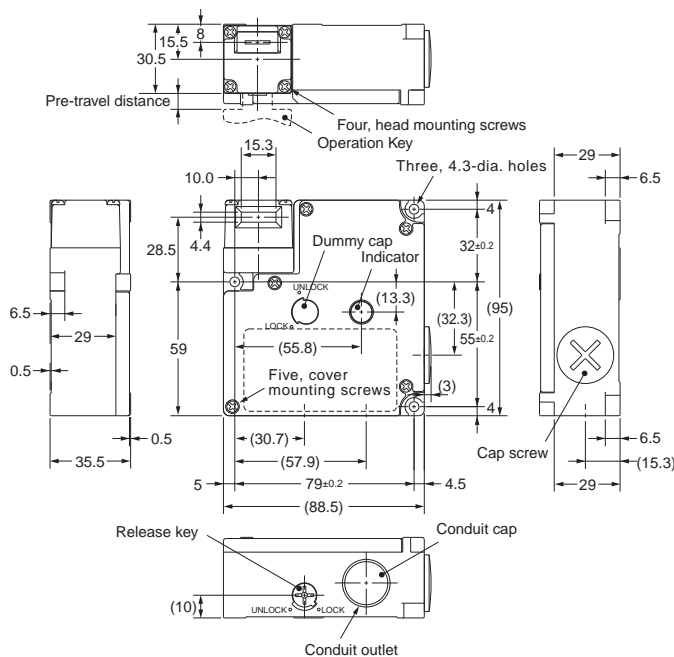
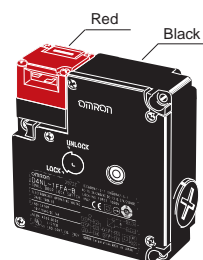

Operating characteristics	Model	D4NL-□□□□-B D4NL-□□□□-□□□-SJ
Key insertion force Key extraction force		15 N max. 30 N max.
Pre-travel distance		9 mm max.
Movement before being locked		3 mm min.

D4NL-□□□□-B4

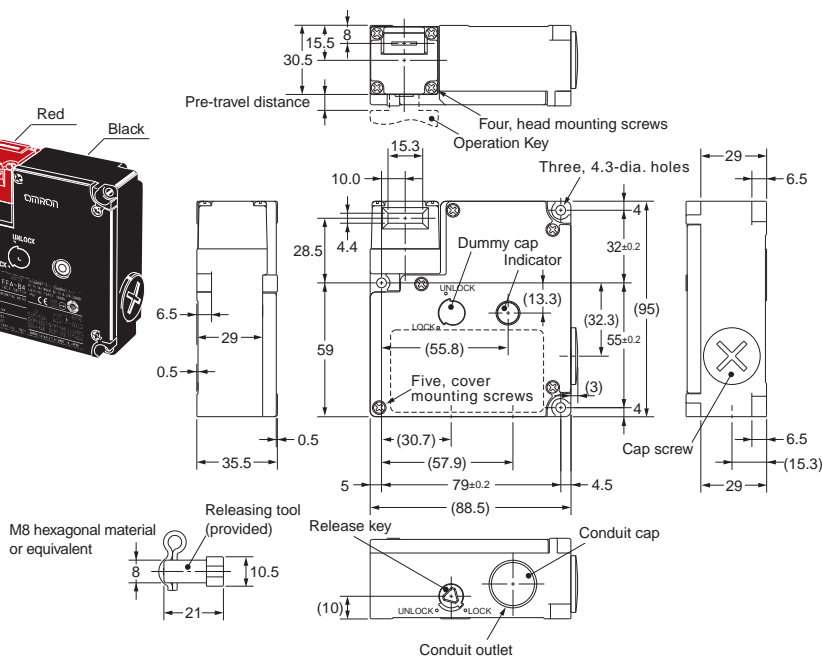
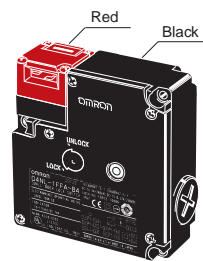

Operating characteristics	Model	D4NL-□□□□-B4
Key insertion force Key extraction force		15 N max. 30 N max.
Pre-travel distance		9 mm max.
Movement before being locked		3 mm min.

Note: 1. Unless otherwise specified, a tolerance of ± 0.4 mm applies to all dimensions.
 2. There are fluctuations in the contact ON/OFF timing for Switches with multiple poles (2NC, 2NC/1NO, or 3NC). Confirm performance before application.

With Operation Key Inserted

D4NL + D4DS-K1
(with Front-inserted Operation Key)

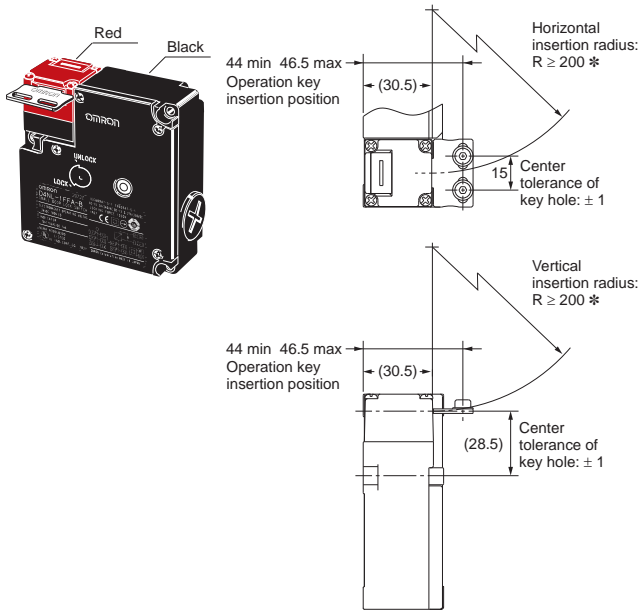

D4NL + D4DS-K1
(with Top-inserted Operation Key)

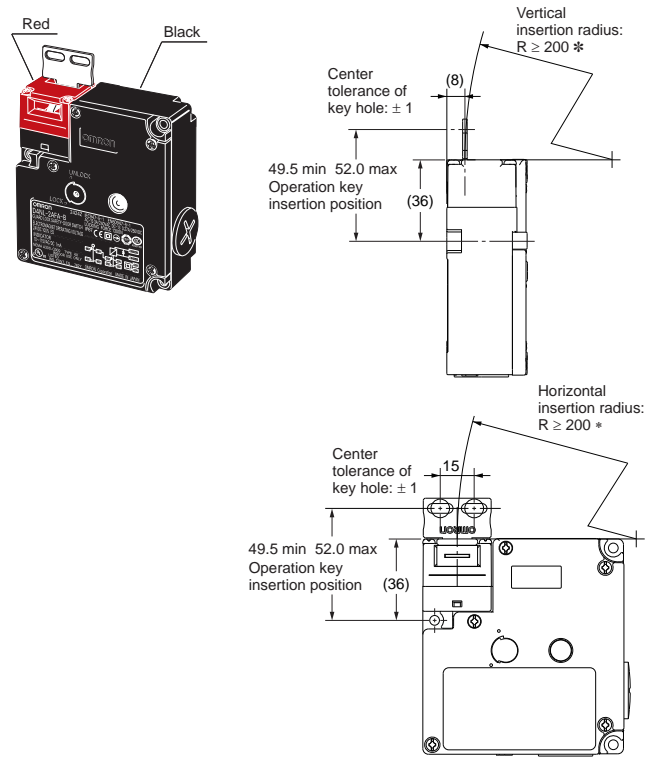

D4NL + D4DS-K2
(with Front-inserted Operation Key)

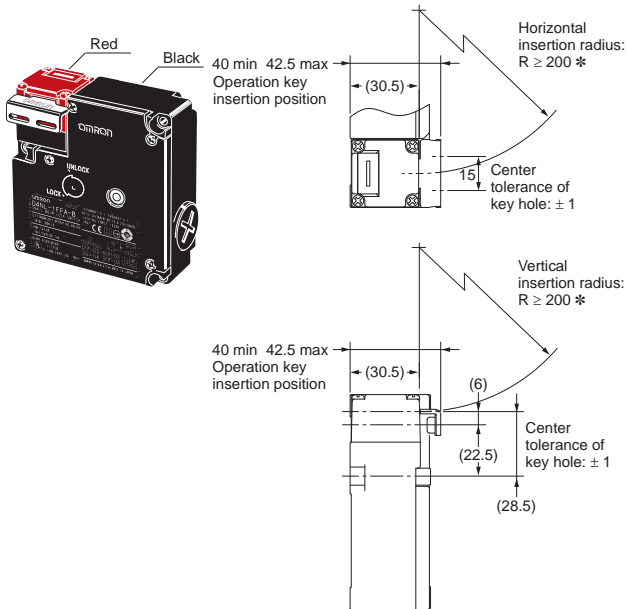

D4NL + D4DS-K2
(with Top-inserted Operation Key)

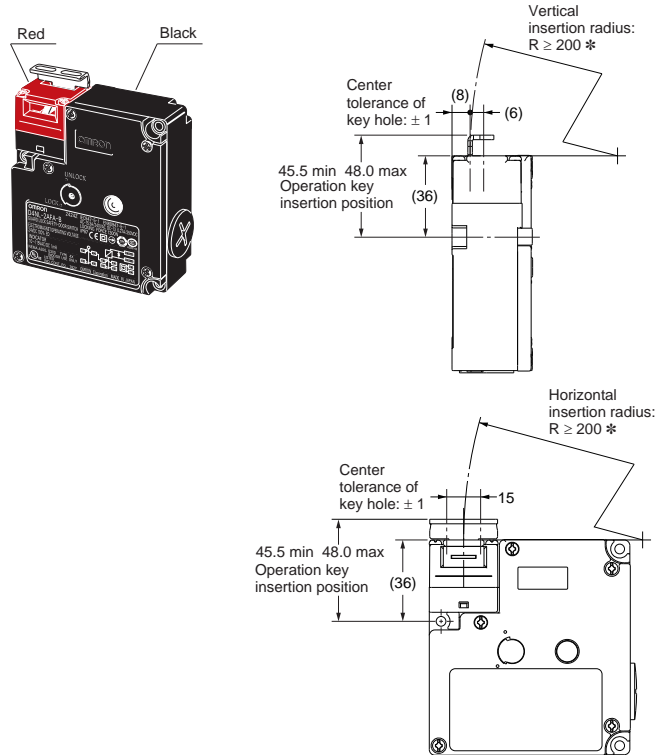

* Insertion radii apply when the rotational center of the Operation Key is in line with a line extending from the front or top Head surface.

**D4NL + D4DS-K3
(with Front-inserted Operation Key)**

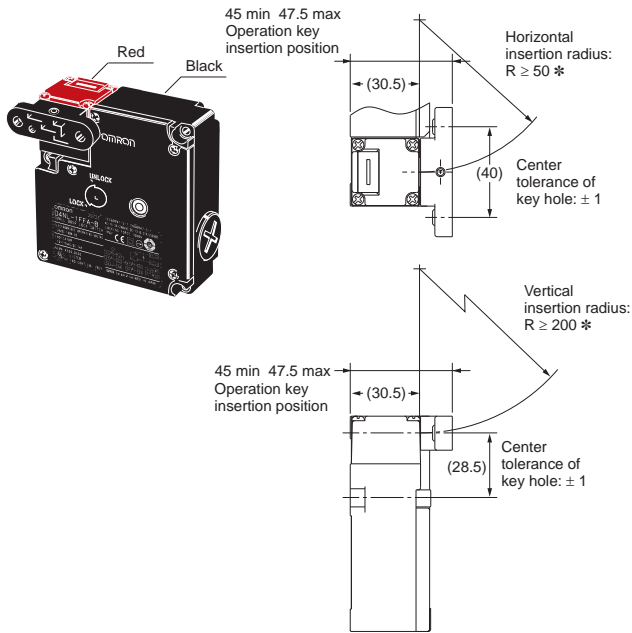

**D4NL + D4DS-K3
(with Top-inserted Operation Key)**

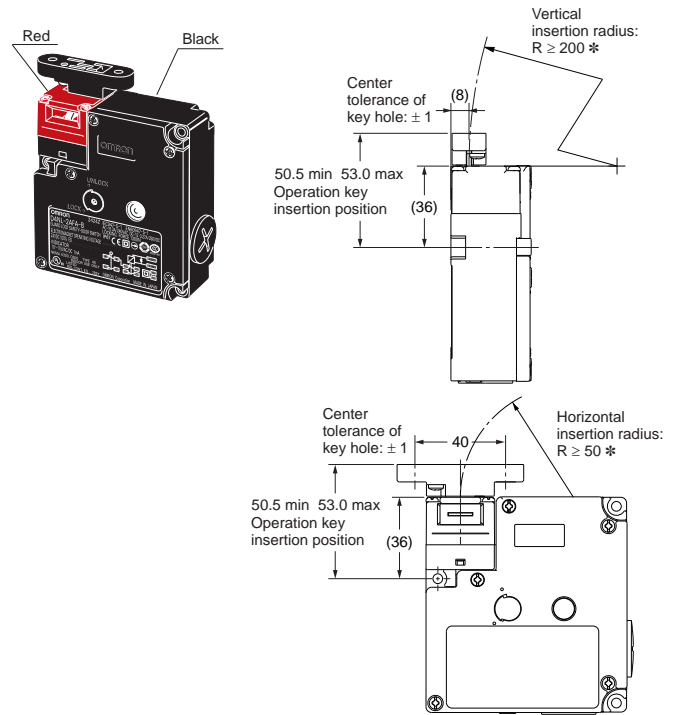

**D4NL + D4DS-K5
(with Front-inserted Operation Key)**

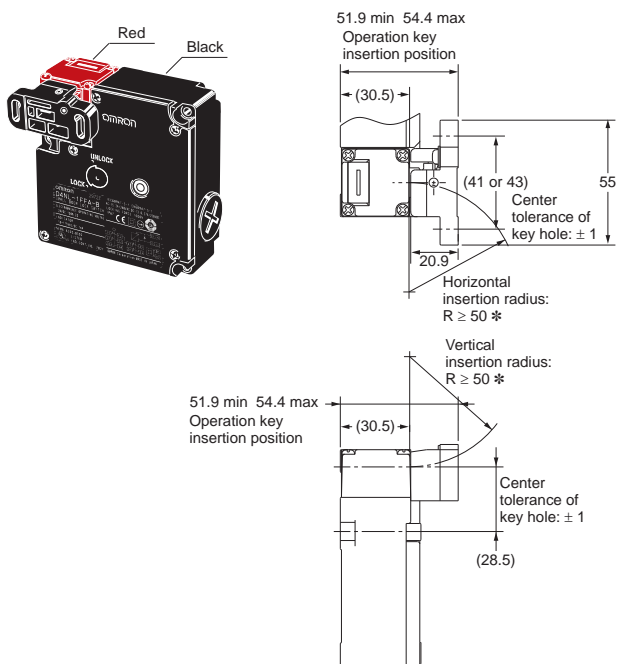

**D4NL + D4DS-K5
(with Top-inserted Operation Key)**

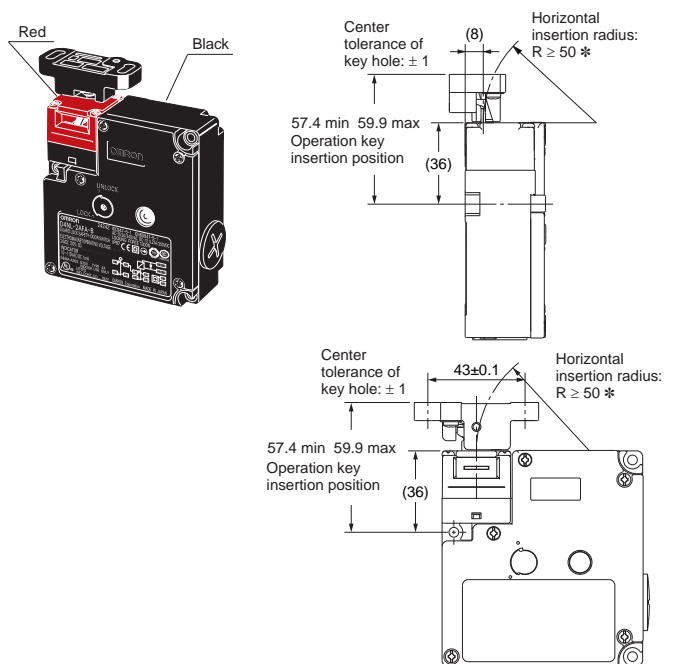

* Insertion radii apply when the rotational center of the Operation Key is in line with a line extending from the front or top Head surface.

Application Examples

Highest achievable PL/ safety category	Model	Stop category	Reset
PLe/4 equivalent	Guard Lock Safety-door Switch D4NL-□□□A-□, -□G□A-□ (Mechanical Lock Type) Safety Limit Switch D4B-N/D4N/D4F Safety Relay Unit G9SA-301 (24 VAC/VDC)	0	Manual

Note: The above PL is only the evaluation result of the example. The PL must be evaluated in an actual application by the customer after confirming the usage conditions.

Application Overview

- After the opening of the guard is permitted by turning ON of the lock release enable signal, the guard is opened by operating the lock release switch S4.
- The guard status is monitored by the Safety Limit Switch S1 and Guard Lock Safety-door Switch S2, and a state in which the power supply to the motor M is turned OFF must be maintained while the guard is open.
- When the guard is closed, lock status is ensured, and the reset switch S3 is pressed, the power supply to the motor M is permitted.

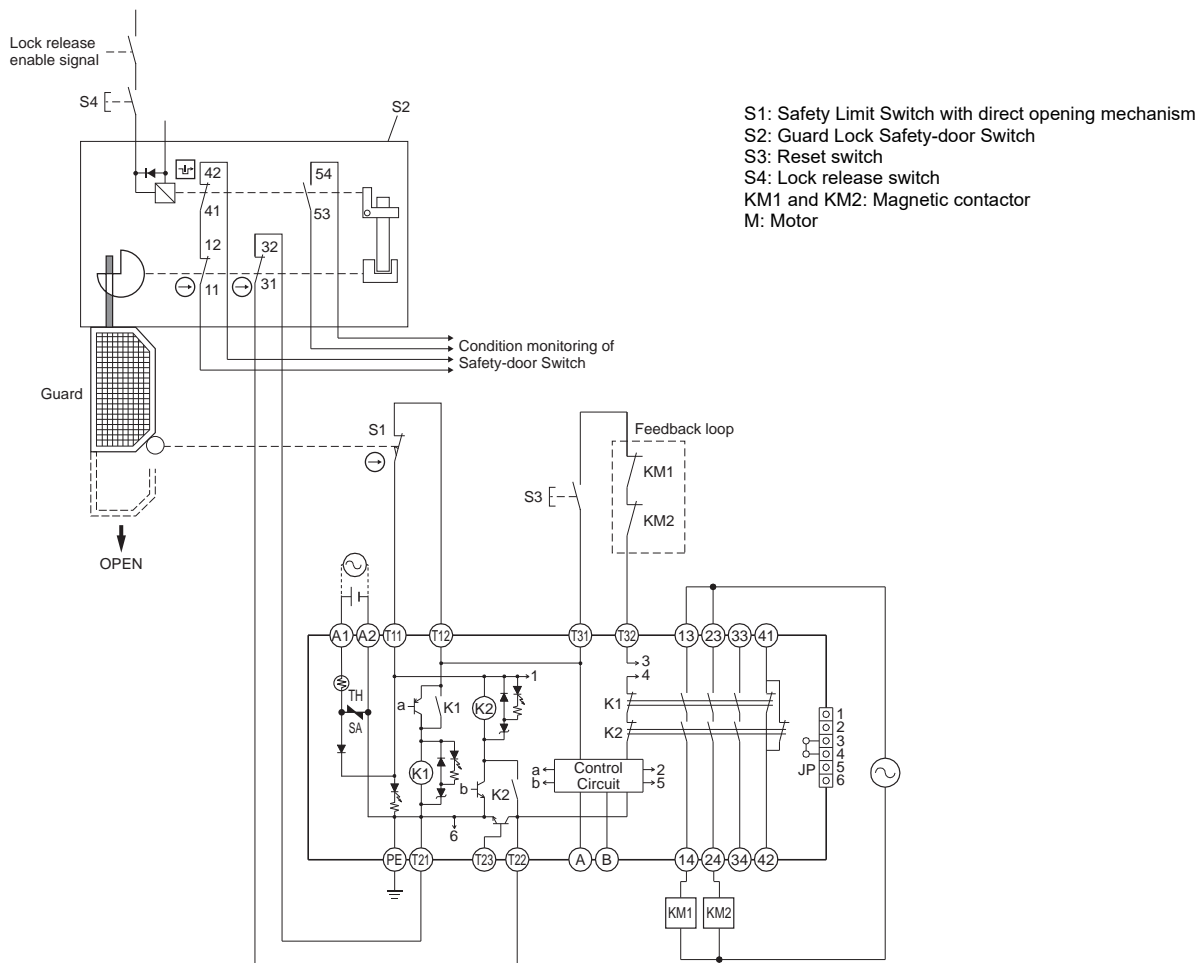

Timing Chart

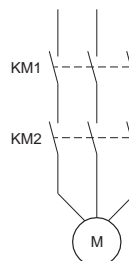
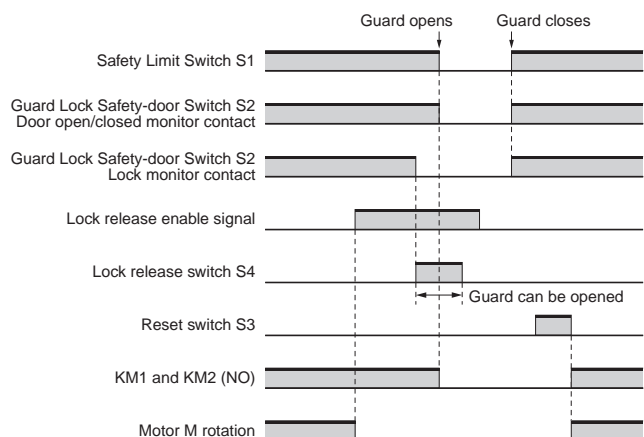



Note: The lock release enable signal must be configured so that it should turn ON after dangerous movement is stopped and safety is ensured for the door to open.

Safety Precautions

Be sure to read the precautions for **All Safety Door Switches** in the website at: <http://www.ia.omron.com/>.

Indication and Meaning for Safe Use

 DANGER	Indicates an imminently hazardous situation which, if not avoided, is likely to result in serious injury or may result in death. Additionally there may be severe property damage.
 CAUTION	Indicates a potentially hazardous situation which, if not avoided, may result in minor or moderate injury or in property damage.
Precautions for Safe Use	Supplementary comments on what to do or avoid doing, to use the product safely.
Precautions for Correct Use	Supplementary comments on what to do or avoid doing, to prevent failure to operate, or undesirable effect on product performance.

DANGER

Injury may occasionally occur. Always check to make sure that the safety functions operate correctly before using the machine. The safety functions may not operate correctly because of wiring mistakes, setting mistakes, or Switch malfunction, causing some machines to continue operating in situations where they should be stopped. 

Injury may occasionally occur. If the machine is used with the release key in the UNLOCK position, the electromagnetic lock may not operate, causing some machines to continue operating in situations where they should be stopped. Be sure to put the release key in the LOCK position before using the machine. Also, check the condition of the lock and safety circuits. 

Injury may occasionally occur. Always ensure that the release key is set to "UNLOCK" or that the Operation Key is inserted before changing the direction of the head. Not doing so may damage the Switch, causing some machines to continue operating in situations where they should be stopped. Refer to "Release Key" on page 15. 

Injury may occasionally occur. When the electromagnetic lock function or Switch function is damaged, some machines may continue operating in situations where they should be stopped. Do not use the electromagnetic lock function of the Switch in place of a door lock. Always provide a lock separate from the Switch, attach a warning seal to prevent people from using excessive force to open the door when it is locked, or provide an indicator lamp to show the locked/unlocked status of the door. 

CAUTION

Electric shock may occasionally occur. Do not use metal cable glands or metal conduits. 

Precautions for Safe Use

Installation Environment

- Do not use the Switch submerged in oil or water or in locations continuously subject to splashes of oil or water. Doing so may result in oil or water entering the Switch. (The IP67 degree of protection of the Switch specifies the amount of water penetration after the Switch is submerged in water for a certain period of time.)

Wiring

- Do not switch circuits for two or more standard loads (250 VAC, 3 A). Doing so may adversely affect insulation performance.
- Always attach the cover after completing wiring and before using the Switch. Do not supply power when the cover is not attached. Electric shock may occur if the Switch is used without the cover attached.

Installation

- Make sure the Switch is mounted securely to prevent it from falling off. Otherwise injury may result.
- Do not use the Switch as a stopper. Be sure to install a stopper as shown in the following illustration to ensure that the base of the Operation Key does not strike the Head, and adjust the stopper to be within the setting zone (0.5 to 3 mm) of the base of the Operation Key.
- Do not subject the Switch to a shock that exceeds the Switch's shock resistance of 1,000 m/s².

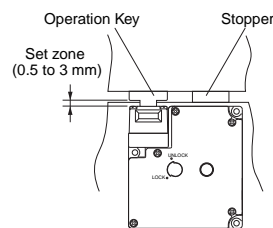

Precautions for Correct Use

The Switch contacts can be used with either standard loads or microloads. Once the contacts have been used to switch a load, however, they cannot be used to switch smaller loads. The contact surfaces will become rough once they have been used and contact reliability for smaller loads may be reduced.

Operation Key

- Use only the designated Operation Key. The Head has been designed so that operation is not possible with a screwdriver or other tools. Using anything other than the designated Operation Key may damage the Switch or affect machine safety.
- Do not operate the Switch with anything other than the special OMRON Operation Key, otherwise the Switch may break or the safety of the system may not be maintained.
- Do not impose excessive force on the Operation Key while the Key is inserted into the Switch or drop the Switch with the Operation Key inserted. Doing either of these may deform the Key or break the Switch.

Release Key

- The release key is used to unlock the Switch in case of emergency or if the power supply to the Switch stops.
- If the release key setting is changed from LOCK to UNLOCK, the lock will be released and the safety door can be opened (mechanical lock models only).
- When a Switch with a solenoid lock is in a locked state (i.e., when the solenoid is ON), do not change the release key from the LOCK to the UNLOCK position. Internal parts may be damaged.
- The release key is set in the unlock position at the factory for the D4NL-□□□□A/B/C and to the lock position for the D4NL-□□□□G/H/J.
- Do not use the release key to start or stop machines.
- The auxiliary lock must only be released by authorized personnel.
- Do not impose a force exceeding 1 N·m on the release key screws. The release key may be damaged and may not operate properly.
- To prevent the release key from being used by unauthorized personnel, set it to LOCK and seal it with sealing wax. After the release key operation should be restored to its sealed before restart.

Figure 1

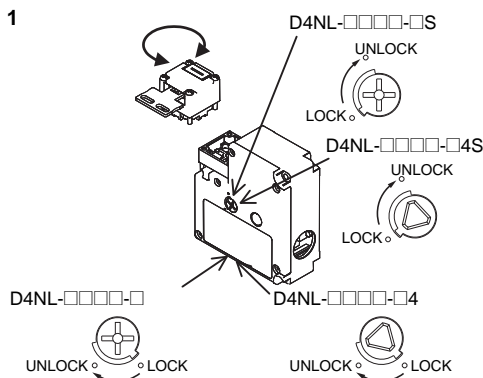

Hinged Door

If an attempt is made to open the door beyond the lock position when the Switch is used for a hinged door at 3a location near to the hinged side, where the Operation Key's insertion radius is comparatively small, the force imposed will be much larger than for locations far from the hinged side, and the lock may be damaged. Mount the Switch close to the handle.

Solenoid Lock Models

The solenoid lock locks the door only when power is supplied to the solenoid. Therefore, the door will be unlocked if the power supply to the solenoid stops. Therefore, do not use solenoid lock models for machines that may be operating and dangerous even after the machine stops operating.

Mounting

Appropriate Tightening Torque

- Loose screws may result in malfunction. Be sure to tighten each screw of the Switch properly.

Type	Appropriate tightening torque
Terminal screw	0.59 to 0.78 N·m
Cover mounting screw	0.49 to 0.69 N·m
Head mounting screw	0.49 to 0.59 N·m
Operation Key mounting screw	2.35 to 2.75 N·m
Switch mounting screw	0.49 to 0.69 N·m
Cable gland	1.77 to 2.16 N·m
Cap screw	1.27 to 1.67 N·m

- When loosening a screw with an electrical screwdriver or similar tool while pressing down on the screw head, do not continue turning the screw past the point where the threads disengage. Doing so may strip the end of the threads.

Switch and Operation Key Mounting

- Use M4 screws and washers to mount the Switch and Operation Key, and tighten the screws to a suitable torque. To ensure safety, use screws that cannot be easily removed or another means to prevent the Switch and Operation Key from easily being removed.

Mounting Holes for Switches

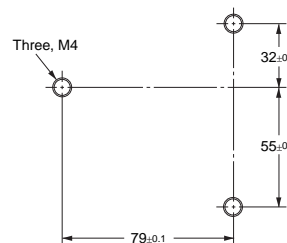

Mounting Holes for Operation Keys

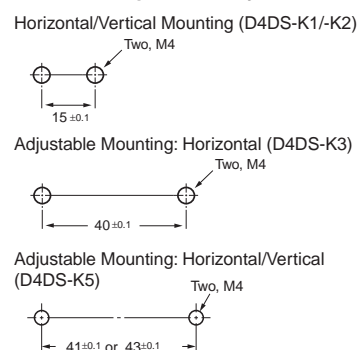

- If the Switch is back-mounted, the release key can be operated only from the bottom and the indicator cannot be used.
- Ensure that the alignment offset between the Operation Key and the key hole does not exceed ± 1 mm. If the Operation Key is offset or at an angle, accelerated wear or damage to the Switch may result.
- Observe the specified insertion radius for the Operation Key and insert it in a direction perpendicular to the key hole.
- Do not impose excessive force on the Operation Key while the Key is inserted into the Switch or drop the Switch with the Operation Key inserted. Doing either of these may deform the Key or break the Switch.

Head Direction

- Remove the four screws of the head to enable changing the mounting direction of the head. The head can be mounted in four directions. Ensure that no foreign material enters the interior of the Switch.
- Do not change the head direction with the cover removed.
- Do not insert or remove the Operation Key with the Switch head removed. Doing so may make it impossible to insert the Operation Key.

Attaching a Cover

- When attaching a cover, be sure that the seal rubber is in place and that there is no foreign material present. If the cover is attached with the seal rubber out of place or if foreign material is stuck to the rubber, a proper seal will not be obtained.
- Do not use any screws to connect the cover other than the specified ones. The seal characteristics may be reduced.

Securing the Door

When the door is closed (with the Operation Key inserted), the Operation Key may exceed the set zone because of, for example, the door's own weight, machine vibration, or the door cushion rubber. Also, it may not be possible to pull out the Operation Key if there is weight placed on the Operation Key. Secure the door with a stopper so that the Switch is not included as the locking member of the door.

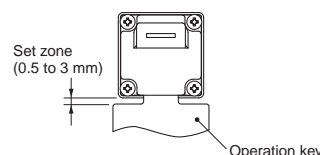

Solenoid

- The solenoid will heat when it carries current. Do not touch it.
- A DC solenoid has polarity. Confirm terminal polarity before wiring it.

Wiring

Wiring Precautions

- Do not wire the Switch while power is being supplied. Doing so may result in electric shock.
- Do not let particles, such as small pieces of lead wire, enter the switch body when wiring.
- When connecting to the terminals via insulating tube and M3.5 crimp terminals, cross the crimp terminals as shown above so that they do not rise up onto the case or the cover.
- Applicable lead wire size: AWG20 to AWG18 (0.5 to 0.75 mm²). Use lead wires of an appropriate length. Not doing so may result in excess length causing the cover to rise and not fit properly.
- Do not push crimp terminals into gaps in the case interior. Doing so may cause damage or deformation of the case.
- Use terminals having the thickness of 0.5 mm or less to avoid the contact between the terminal and the interior of the Switch case.

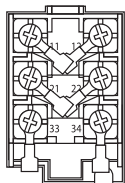

[Reference] The terminals listed below have thickness of 0.5 mm or less.

Manufacturer	Model
J.S.T. Mfg Co.	FN0.5-3.7 (F Type) No. 5-3.7 (Straight Type)

t: 0.5 mm
dz dia.: 3.7 mm
D dia.: 2.9 mm
B: 6.6 mm
L: 19 mm
F: 7.7 mm
I: 8.0 mm

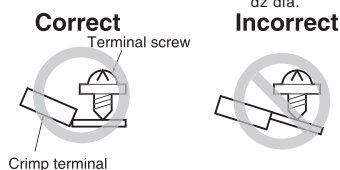
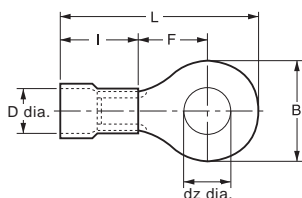

Processing the Conduit Outlet

- Use a recommended cable gland and tighten it with the appropriate tightening torque. The case may be damaged if an excessive tightening torque is applied.
- Use a cable conforming to the diameter of the cable gland to be used.
- Attach a conduit cap to the unused conduit outlet when wiring and tighten it to a suitable torque. The conduit cap is provided with the Switch.

Cable Gland

- Use a commercially available cable gland.
- Use a cable gland with the length of the screw not exceeding 11 mm to avoid interference with the inside of the Switch case.

Terms and Conditions Agreement

Read and understand this catalog.

Please read and understand this catalog before purchasing the products. Please consult your OMRON representative if you have any questions or comments.

Warranties.

(a) Exclusive Warranty. Omron's exclusive warranty is that the Products will be free from defects in materials and workmanship for a period of twelve months from the date of sale by Omron (or such other period expressed in writing by Omron). Omron disclaims all other warranties, express or implied.

(b) Limitations. OMRON MAKES NO WARRANTY OR REPRESENTATION, EXPRESS OR IMPLIED, ABOUT NON-INFRINGEMENT, MERCHANTABILITY OR FITNESS FOR A PARTICULAR PURPOSE OF THE PRODUCTS. BUYER ACKNOWLEDGES THAT IT ALONE HAS DETERMINED THAT THE PRODUCTS WILL SUITABLY MEET THE REQUIREMENTS OF THEIR INTENDED USE.

Omron further disclaims all warranties and responsibility of any type for claims or expenses based on infringement by the Products or otherwise of any intellectual property right. (c) Buyer Remedy. Omron's sole obligation hereunder shall be, at Omron's election, to (i) replace (in the form originally shipped with Buyer responsible for labor charges for removal or replacement thereof) the non-complying Product, (ii) repair the non-complying Product, or (iii) repay or credit Buyer an amount equal to the purchase price of the non-complying Product; provided that in no event shall Omron be responsible for warranty, repair, indemnity or any other claims or expenses regarding the Products unless Omron's analysis confirms that the Products were properly handled, stored, installed and maintained and not subject to contamination, abuse, misuse or inappropriate modification. Return of any Products by Buyer must be approved in writing by Omron before shipment. Omron Companies shall not be liable for the suitability or unsuitability or the results from the use of Products in combination with any electrical or electronic components, circuits, system assemblies or any other materials or substances or environments. Any advice, recommendations or information given orally or in writing, are not to be construed as an amendment or addition to the above warranty.

See <http://www.omron.com/global/> or contact your Omron representative for published information.

Limitation on Liability: Etc.

OMRON COMPANIES SHALL NOT BE LIABLE FOR SPECIAL, INDIRECT, INCIDENTAL, OR CONSEQUENTIAL DAMAGES, LOSS OF PROFITS OR PRODUCTION OR COMMERCIAL LOSS IN ANY WAY CONNECTED WITH THE PRODUCTS, WHETHER SUCH CLAIM IS BASED IN CONTRACT, WARRANTY, NEGLIGENCE OR STRICT LIABILITY.

Further, in no event shall liability of Omron Companies exceed the individual price of the Product on which liability is asserted.

Suitability of Use.

Omron Companies shall not be responsible for conformity with any standards, codes or regulations which apply to the combination of the Product in the Buyer's application or use of the Product. At Buyer's request, Omron will provide applicable third party certification documents identifying ratings and limitations of use which apply to the Product. This information by itself is not sufficient for a complete determination of the suitability of the Product in combination with the end product, machine, system, or other application or use. Buyer shall be solely responsible for determining appropriateness of the particular Product with respect to Buyer's application, product or system. Buyer shall take application responsibility in all cases.

NEVER USE THE PRODUCT FOR AN APPLICATION INVOLVING SERIOUS RISK TO LIFE OR PROPERTY OR IN LARGE QUANTITIES WITHOUT ENSURING THAT THE SYSTEM AS A WHOLE HAS BEEN DESIGNED TO ADDRESS THE RISKS, AND THAT THE OMRON PRODUCT(S) IS PROPERLY RATED AND INSTALLED FOR THE INTENDED USE WITHIN THE OVERALL EQUIPMENT OR SYSTEM.

Programmable Products.

Omron Companies shall not be responsible for the user's programming of a programmable Product, or any consequence thereof.

Performance Data.

Data presented in Omron Company websites, catalogs and other materials is provided as a guide for the user in determining suitability and does not constitute a warranty. It may represent the result of Omron's test conditions, and the user must correlate it to actual application requirements. Actual performance is subject to the Omron's Warranty and Limitations of Liability.

Change in Specifications.

Product specifications and accessories may be changed at any time based on improvements and other reasons. It is our practice to change part numbers when published ratings or features are changed, or when significant construction changes are made. However, some specifications of the Product may be changed without any notice. When in doubt, special part numbers may be assigned to fix or establish key specifications for your application. Please consult with your Omron's representative at any time to confirm actual specifications of purchased Product.

Errors and Omissions.

Information presented by Omron Companies has been checked and is believed to be accurate; however, no responsibility is assumed for clerical, typographical or proofreading errors or omissions.

2024.7

In the interest of product improvement, specifications are subject to change without notice.

OMRON Corporation
Industrial Automation Company

<http://www.ia.omron.com/>

(c)Copyright OMRON Corporation 2024 All Right Reserved.